



Workshop Manual

electrical wiring

SUPPLEMENT

L300 '98

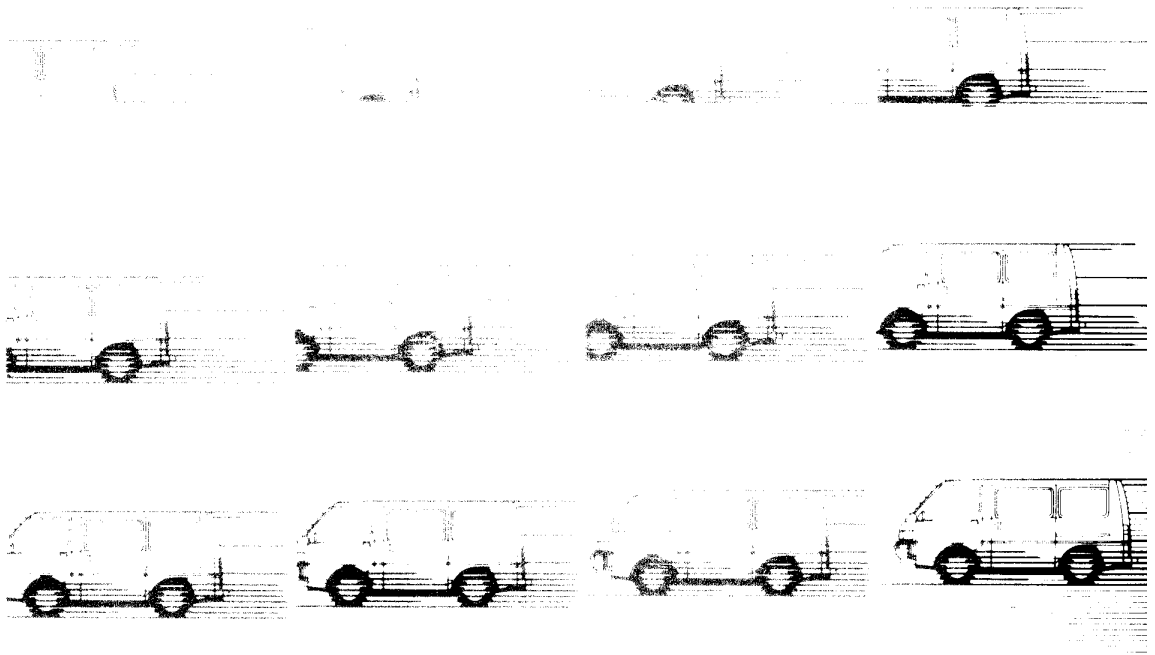
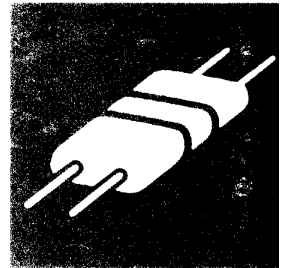

MITSUBISHI L300

ELECTRICAL WIRING SUPPLEMENT

FOREWORD

This publication is a supplement to the Electrical Wiring Manual Pub. Nos. PHWE8907, PHWE8907-1, PHWE8907-2, PHWE8907-3, PHWE8907-4, PHWE8907-5 and contains only additions and changes to the original issue.

It is recommended that all service mechanics engaged in the servicing of the vehicle refer to the following publications as well as this manual.

WORKSHOP MANUAL ENGINE GROUP

PWEE□□□□
(Looseleaf edition)

CHASSIS GROUP

PWWE8608
(Looseleaf edition)
PWWE9409□

PARTS CATALOGUE

B603180□A□
B803180□A□
BFA3180□A□

All information, illustrations and product descriptions contained in this manual are current as of time of publication. We, however reserve the right to make changes at any time without prior notice or obligation.

GROUP INDEX

OUTLINE OF CHANGES

HOW TO READ THE
WIRING DIAGRAMS

WIRING HARNESS
CONFIGURATION DIAGRAMS

SINGLE PART
INSTALLATION POSITION

CIRCUIT DIAGRAM

1

2

3

4



HOW TO USE THIS MANUAL

CONTENTS

The preceding page contains GROUP INDEX which lists the group title and group number.

PAGE NUMBERS

All page numbers consist of two sets of digits separated by a dash. The digits preceding the dash identify the number of the group. The digits following the dash represent the consecutive page number within the group. The page numbers can be found on the top left or right of each page.

OPERATION AND TROUBLESHOOTING HINTS

In the GROUP 4 circuit diagrams, the operation and troubleshooting hints are given on the previous page or following page for each circuit where necessary.

OUTLINE OF CHANGES

CONTENTS

WIRING HARNESS CONFIGURATION DIAGRAMS	2	CIRCUIT DIAGRAM	3
SINGLE PART INSTALLATION POSITION ...	2		



WIRING HARNESS CONFIGURATION DIAGRAMS

Wiring harness configuration diagram			Description of changes	
Connector symbol	Name	Reference page		
A	INSTRUMENT PANEL	L.H. drive vehicles	2-2	<p>The following connectors have been added to correspond to the adoption of a supplemental restraint system (SRS).</p> <ul style="list-style-type: none"> ● Headlamp relay (HI) (A-137) ● Headlamp relay (LO) (A-138) ● Horn relay (A-139) ● Air bag module (A-140) ● SRS-ECU (A-141) ● Column switch (A-142, A-143, A-144) ● Clock spring (A-145, A-146) <p>A 12-pin diagnosis connector (A-122) has been added to vehicles with MPI.</p>
		R.H. drive vehicles	2-2	
B	ENGINE ROOM AND UNDER FLOOR	Petrol-powered vehicles <L.H. drive vehicles>	2-3	<p>A connector (B-136) has been added to correspond to changes in the MPI control unit.</p>
		Petrol-powered vehicles <R.H. drive vehicles>	2-3	

SINGLE PART INSTALLATION POSITION

Location of change	Reference page	Description of change
RELAY MOUNTING LOCATIONS	3-2	Headlamp relays (HI, LO) and a horn relay have been added to correspond to the adoption of a supplemental restraint system (SRS).
CONTROL UNIT MOUNTING LOCATIONS	3-2	A SRS-ECU has been added to correspond to the adoption of a supplemental restraint system (SRS).

CIRCUIT DIAGRAMS

Circuit diagrams			Description of changes
Title	Classification	Reference page	
MPI SYSTEM	-	4-2	The circuit diagram has been changed to correspond to changes in the MPI control unit.
HEADLAMP	L.H. drive vehicles without daytime running lamp <with SRS>	4-6	A new circuit diagram has been established to correspond to the adoption of a supplemental restraint system (SRS).
	L.H. drive vehicles with daytime running lamp <with SRS>	4-8	
	R.H. drive vehicles <with SRS>	4-10	
HEADLAMP LEVELING	Vehicles with SRS	4-12	
TAIL LAMP, POSITION LAMP AND LICENCE PLATE LAMP	Vehicles without daytime running lamp	4-14	The column switch circuit has been changed to correspond to the adoption of a supplemental restraint system (SRS).
	Vehicles with daytime running lamp	4-16	
REAR FOG LAMP	L.H. drive vehicles without daytime running lamp <without SRS>	4-18	Circuit diagrams have been changed and added to correspond to changes to the rear fog lamp switch and the adoption of a supplemental restraint system (SRS).
	L.H. drive vehicles without daytime running lamp <with SRS>	4-20	
	L.H. drive vehicles with daytime running lamp <without SRS>	4-22	
	L.H. drive vehicles with daytime running lamp <with SRS>	4-24	
	R.H. drive vehicles <without SRS>	4-26	
	R.H. drive vehicles <with SRS>	4-28	
ILLUMINATION LAMP	-	4-30	The column switch circuit has been changed to correspond to the adoption of a supplemental restraint system (SRS).
TURN-SIGNAL LAMP AND HAZARD LAMP	-	4-32	
STOP LAMP	-	4-34	The circuit diagram has been changed to correspond to changes to the high-mounted stop lamp.

4

OUTLINE OF CHANGES – Circuit Diagrams

Circuit diagrams			Description of changes
Title	Classification	Reference page	
HORN	Vehicles with SRS	4-35	A new circuit diagram has been established to correspond to the adoption of a supplemental restraint system (SRS).
WIPER AND WASHER	Vehicles with SRS	4-36	
HEADLAMP WASHER	L.H. drive vehicles with SRS	4-38	
SUPPLEMENTAL RESTRAINT SYSTEM (SRS)	-	4-40	
CENTRALIZED JUNCTION	MULTI-PURPOSE FUSE	4-42	Fuse Nos. 14 and 15 have been added to correspond to the adoption of a supplemental restraint system (SRS).

HOW TO READ THE WIRING DIAGRAMS

CONTENTS

MODELS 1-2



MODELS

Model code		Engine model	Transmission model	Fuel supply system	Body type
P03V	LNEL6	4G63-16VALVE	R5M21 (2WD-5MT) <Floor shift>	MPI	Window van
	GLNEL6/R6				Panel van
P13V	JLNEL6/R6				Panel van, High roof, Long body
P05V	GLNL6/R6	4D56		Diesel fuel injection	Panel van
P15V	HLNL6				Window van, High roof, Long body
	JLNL6/R6				Panel van, High roof, Long body
P45V	JLNTL6	4D56 with turbocharger	V5M21 (4WD-5MT) <Floor shift>		Panel van, High roof, Long body

WIRING HARNESS CONFIGURATION DIAGRAMS

CONTENTS

INSTRUMENT PANEL A

L.H. drive vehicles 2-2
R.H. drive vehicles 2-2

ENGINE ROOM AND UNDER FLOOR B

Petrol-powered vehicles
<L.H. drive vehicles> 2-3
Petrol-powered vehicles
<R.H. drive vehicles> 2-3

INSTRUMENT PANEL

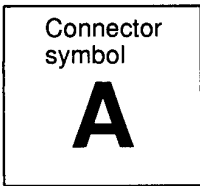

L.H. drive vehicles

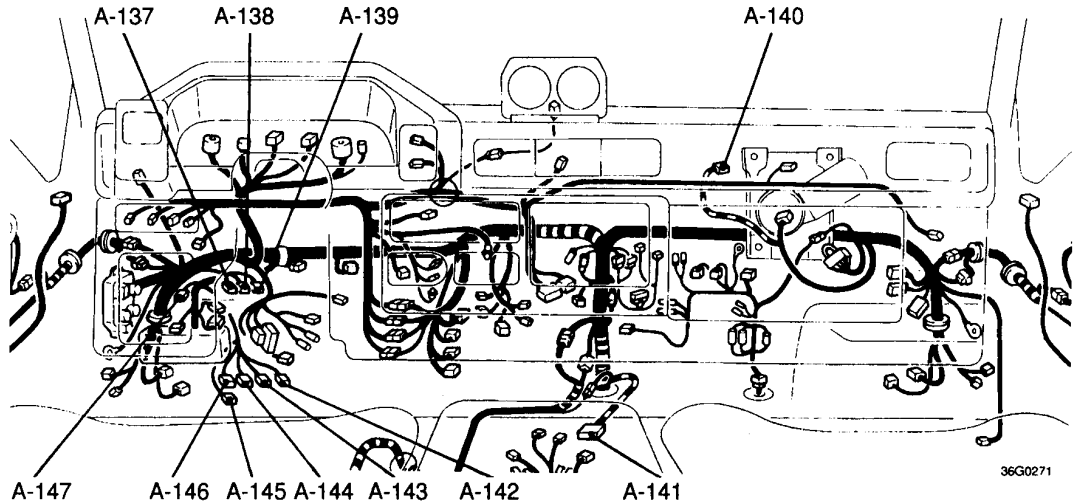

36G0271

R.H. drive vehicles

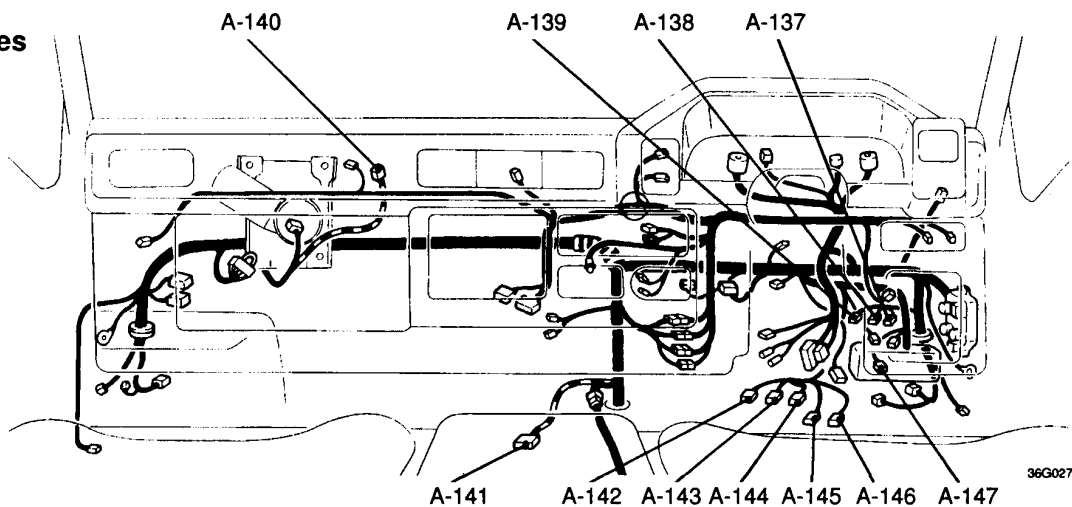

36G0272

- A-137 Headlamp relay (HI) <Vehicles with SRS>
- A-138 Headlamp relay (LO) <Vehicles with SRS>
- A-139 Horn relay <Vehicles with SRS>
- A-140 Air bag module (Passenger's side)
- A-141 SRS-ECU
- A-142 Column switch <Vehicles with SRS>
- A-143 Column switch <Vehicles with SRS>
- A-144 Column switch <Vehicles with SRS>

- A-145 Clock spring <Vehicles with SRS>
- A-146 Clock spring <Vehicles with SRS>
- A-147 Diagnosis connector <MPI>

Remark

Only the numbers of connectors which have been newly added are indicated.

ENGINE ROOM AND UNDER FLOOR

Connector
symbol
B

Petrol-powered vehicles
<L.H. drive vehicles>

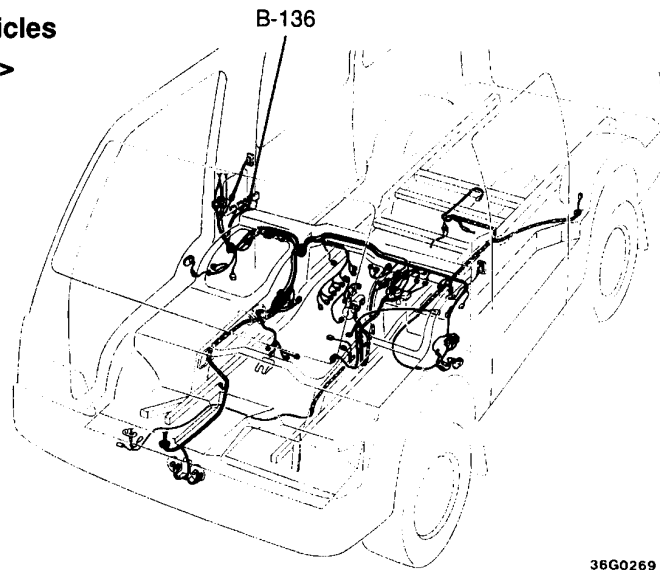

36G0269

Petrol-powered vehicles
<R.H. drive vehicles>

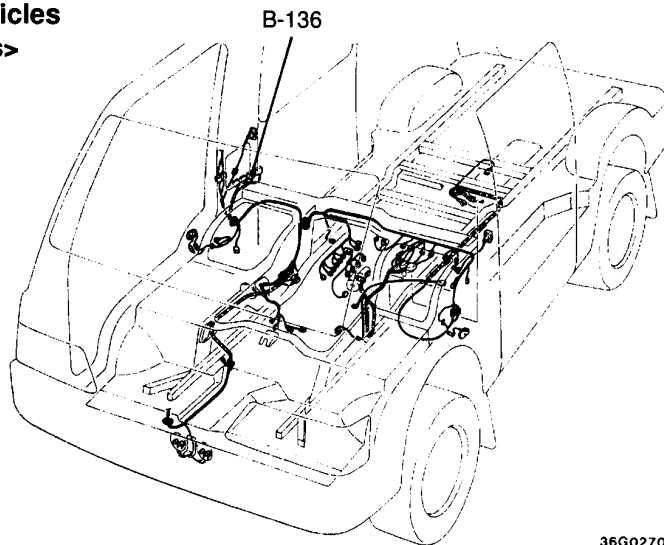

36G0270

B-136 MPI control unit

Remark
Only the numbers of connectors which have been newly added are indicated.

SINGLE PART INSTALLATION POSITION

CONTENTS

RELAY MOUNTING LOCATIONS 3-2

CONTROL UNIT MOUNTING
LOCATIONS 3-2



RELAY MOUNTING LOCATIONS

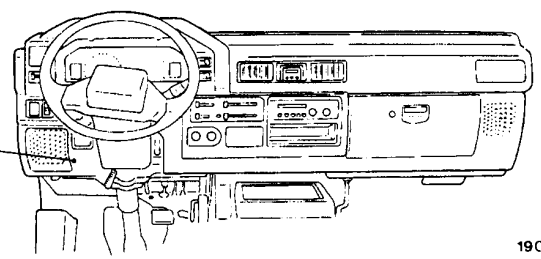
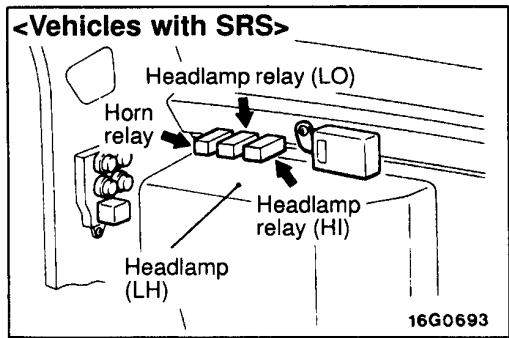

19G0361

CONTROL UNIT MOUNTING LOCATIONS

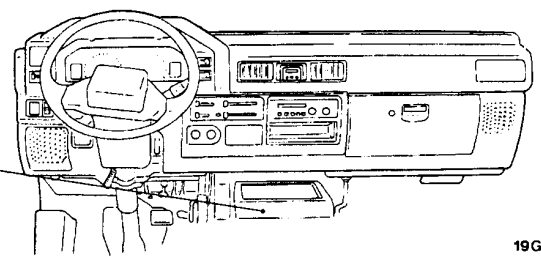
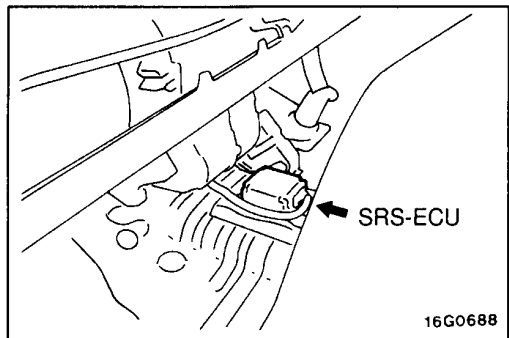

19G0361

CIRCUIT DIAGRAM

CONTENTS

MPI SYSTEM	4-2	ILLUMINATION LAMP	4-30
HEADLAMP		TURN-SIGNAL LAMP AND HAZARD LAMP	4-32
L.H. drive vehicles without daytime running lamp <with SRS>	4-6	STOP LAMP	4-34
L.H. drive vehicles with daytime running lamp <with SRS>	4-8	HORN	
R.H. drive vehicles <with SRS>	4-10	Vehicles with SRS	4-35
HEADLAMP LEVELING		WIPER AND WASHER	
Vehicles with SRS	4-12	Vehicles with SRS	4-36
TAIL LAMP, POSITION LAMP AND LICENCE PLATE LAMP		HEADLAMP WASHER	
Vehicles without daytime running lamp	4-14	L.H. drive vehicles with SRS	4-38
Vehicles with daytime running lamp	4-16	SUPPLEMENTAL RESTRAINT SYSTEM (SRS)	4-40
REAR FOG LAMP		CENTRALIZED JUNCTION	
L.H. drive vehicles without daytime running lamp <without SRS>	4-18	MULTI-PURPOSE FUSE	4-42
L.H. drive vehicles without daytime running lamp <with SRS>	4-20		
L.H. drive vehicles with daytime running lamp <without SRS>	4-22		
L.H. drive vehicles with daytime running lamp <with SRS>	4-24		
R.H. drive vehicles <without SRS>	4-26		
R.H. drive vehicles <with SRS>	4-28		

MPI SYSTEM

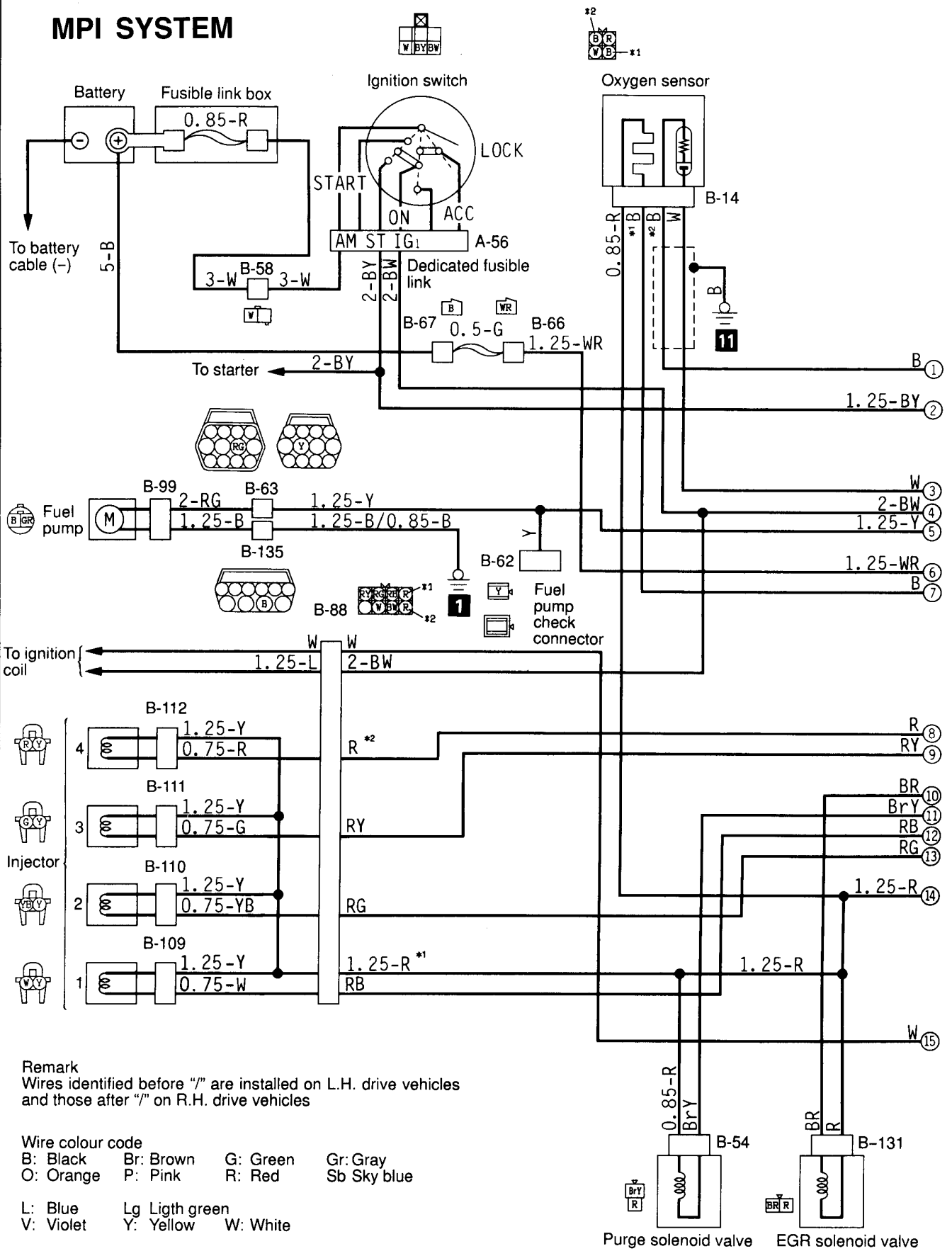

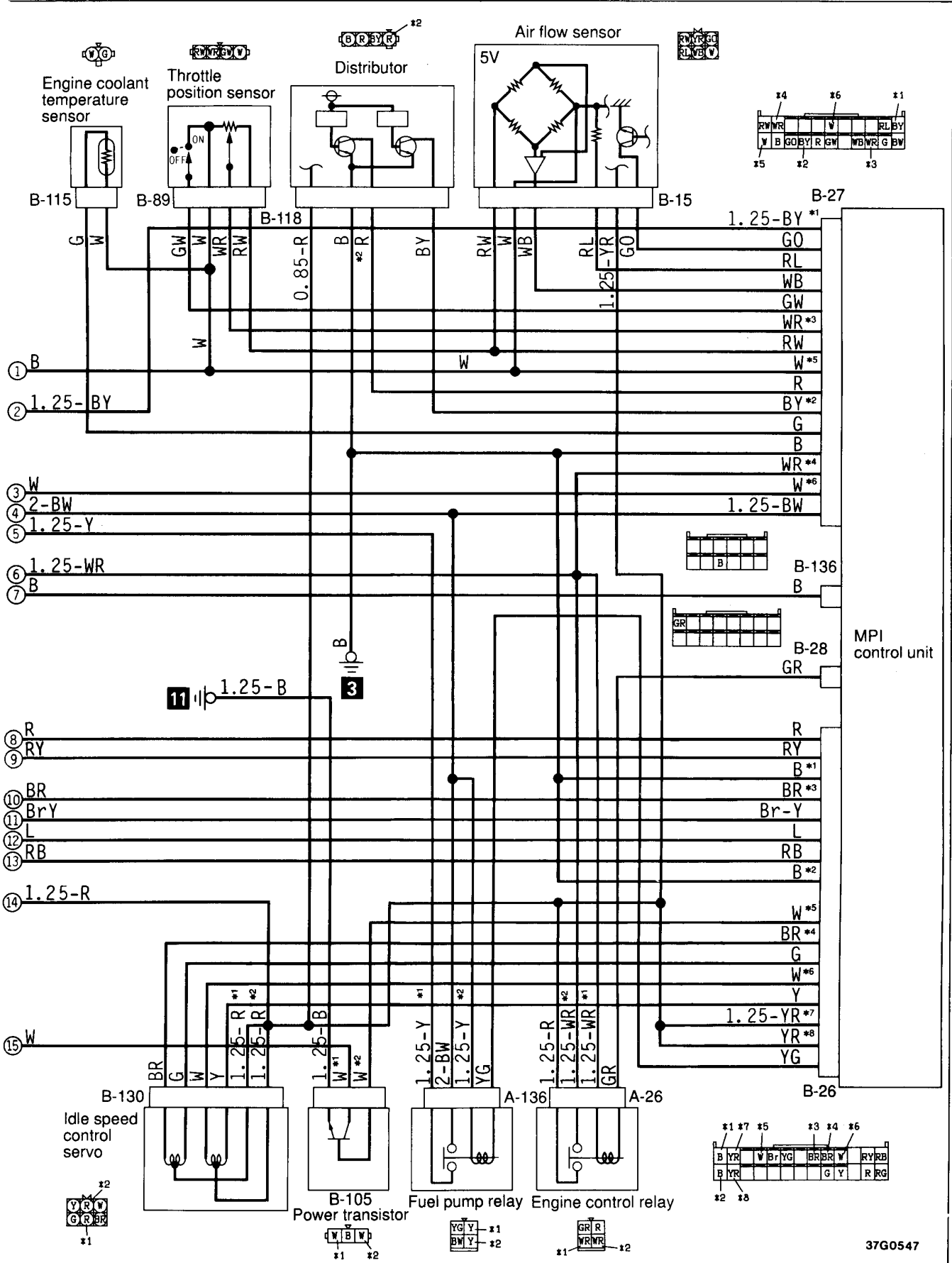

MPI SYSTEM (CONTINUED)

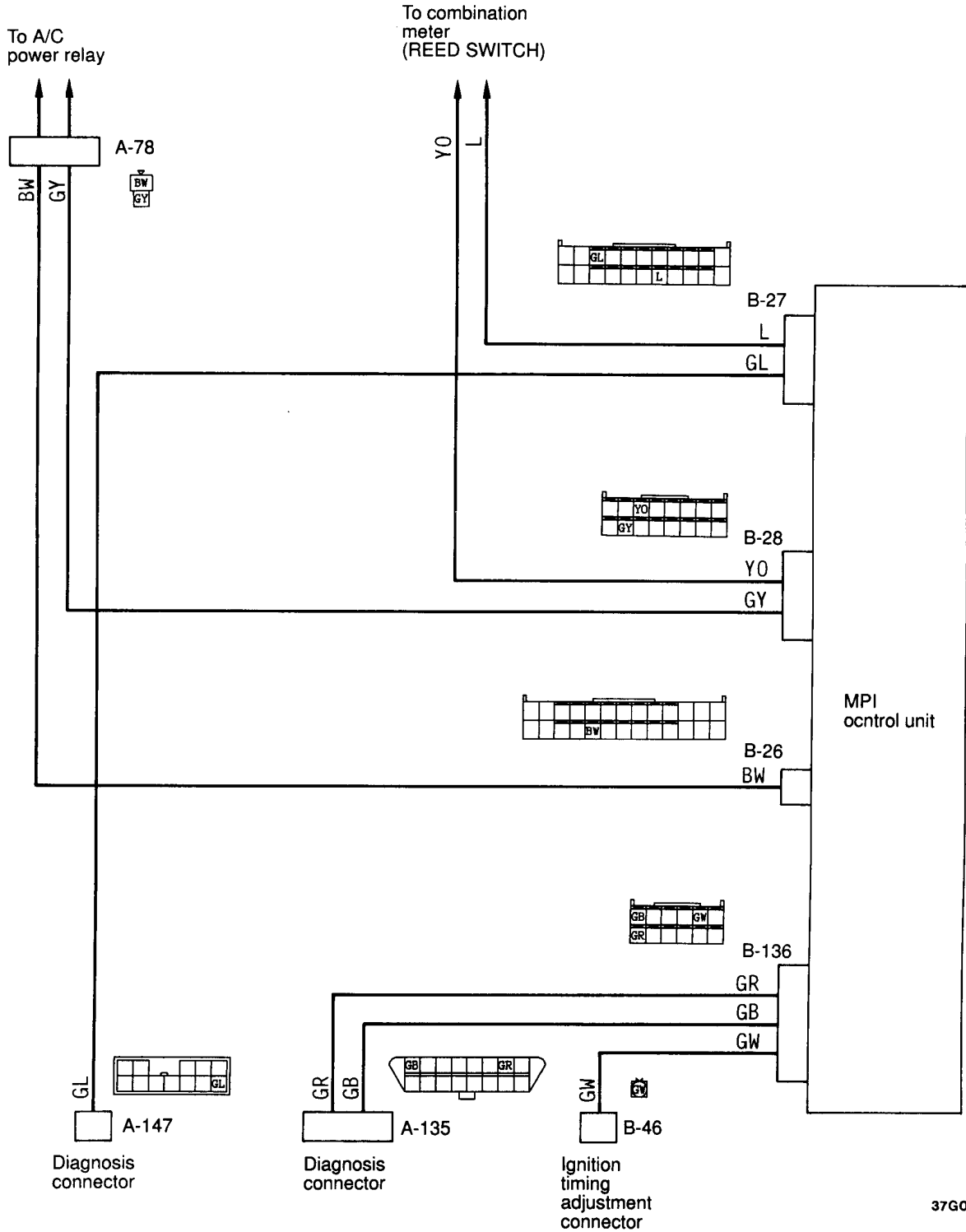

37G0531

Wire colour code

B: Black Br: Brown G: Green Gr: Gray L: Blue Lg: Light green
 O: Orange P: Pink R: Red Sb: Sky blue V: Violet W: White Y: Yellow

NOTES

HEADLAMP

L.H. drive vehicles without daytime running lamp <with SRS>

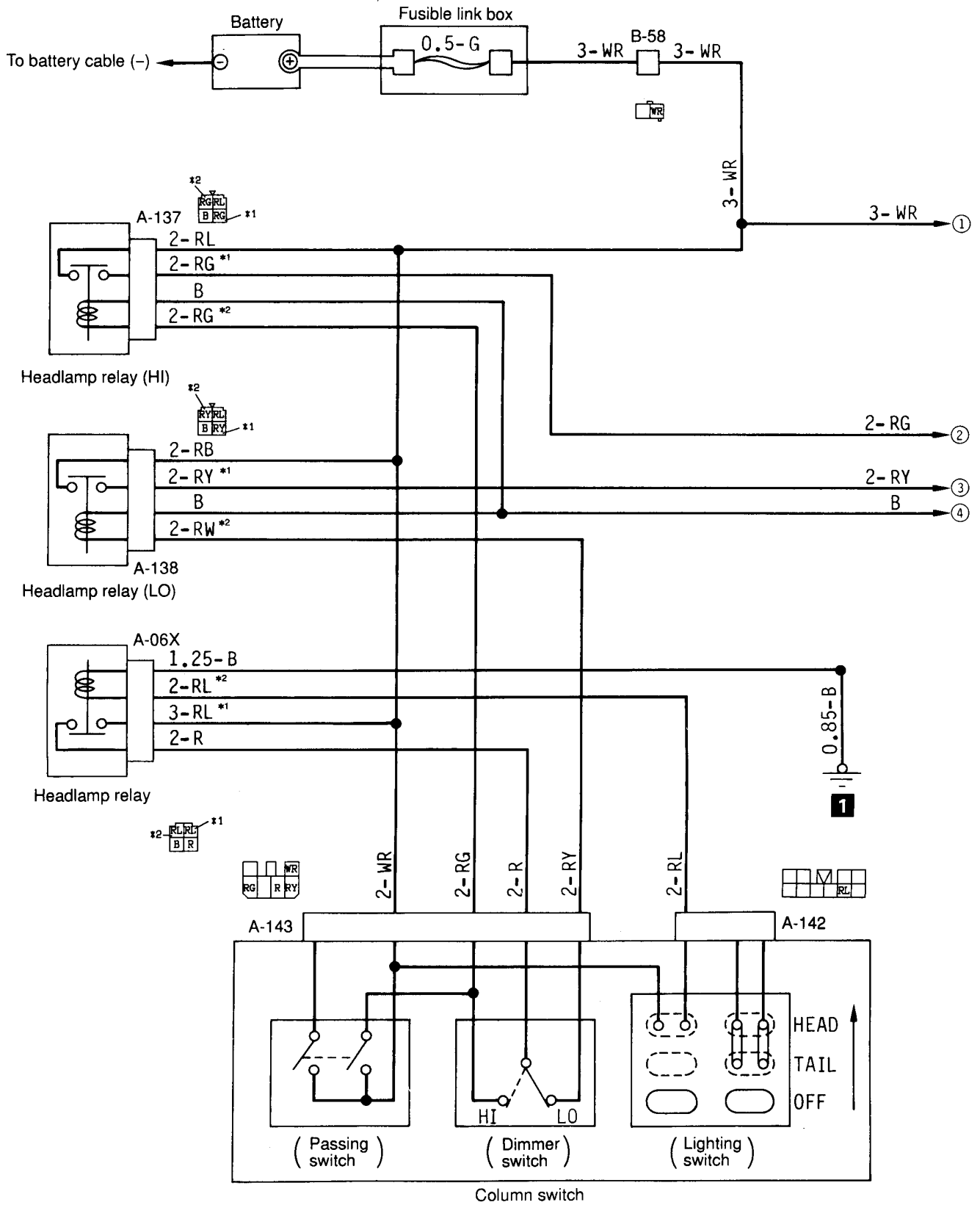

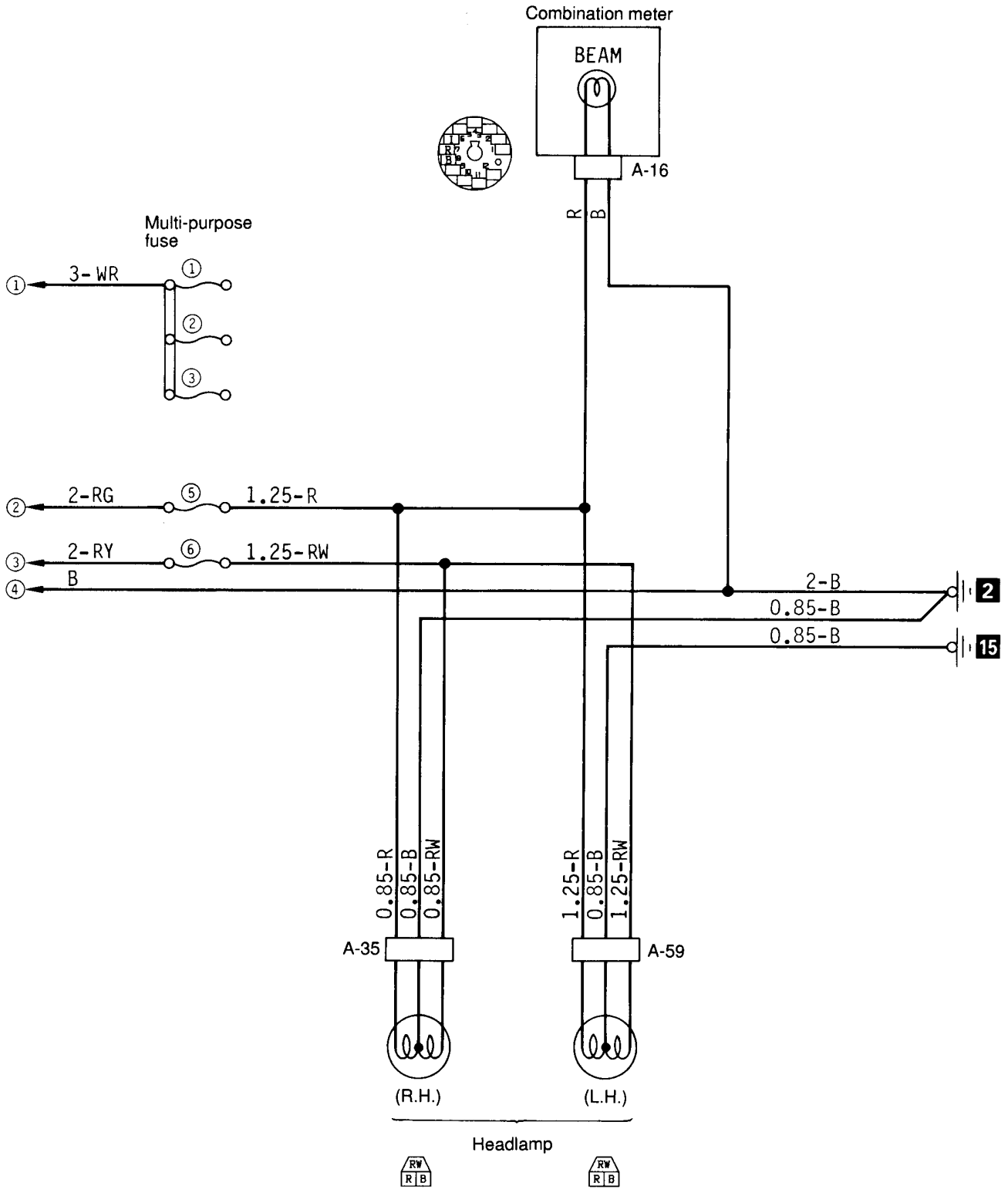

Wire colour code

B: Black	Br: Brown	G: Green	Gr: Gray	L: Blue	Lg: Light green	
O: Orange	P: Pink	R: Red	Sb: Sky blue	V: Violet	W: White	Y: Yellow

HEADLAMP

L.H. drive vehicles with daytime running lamp <with SRS>

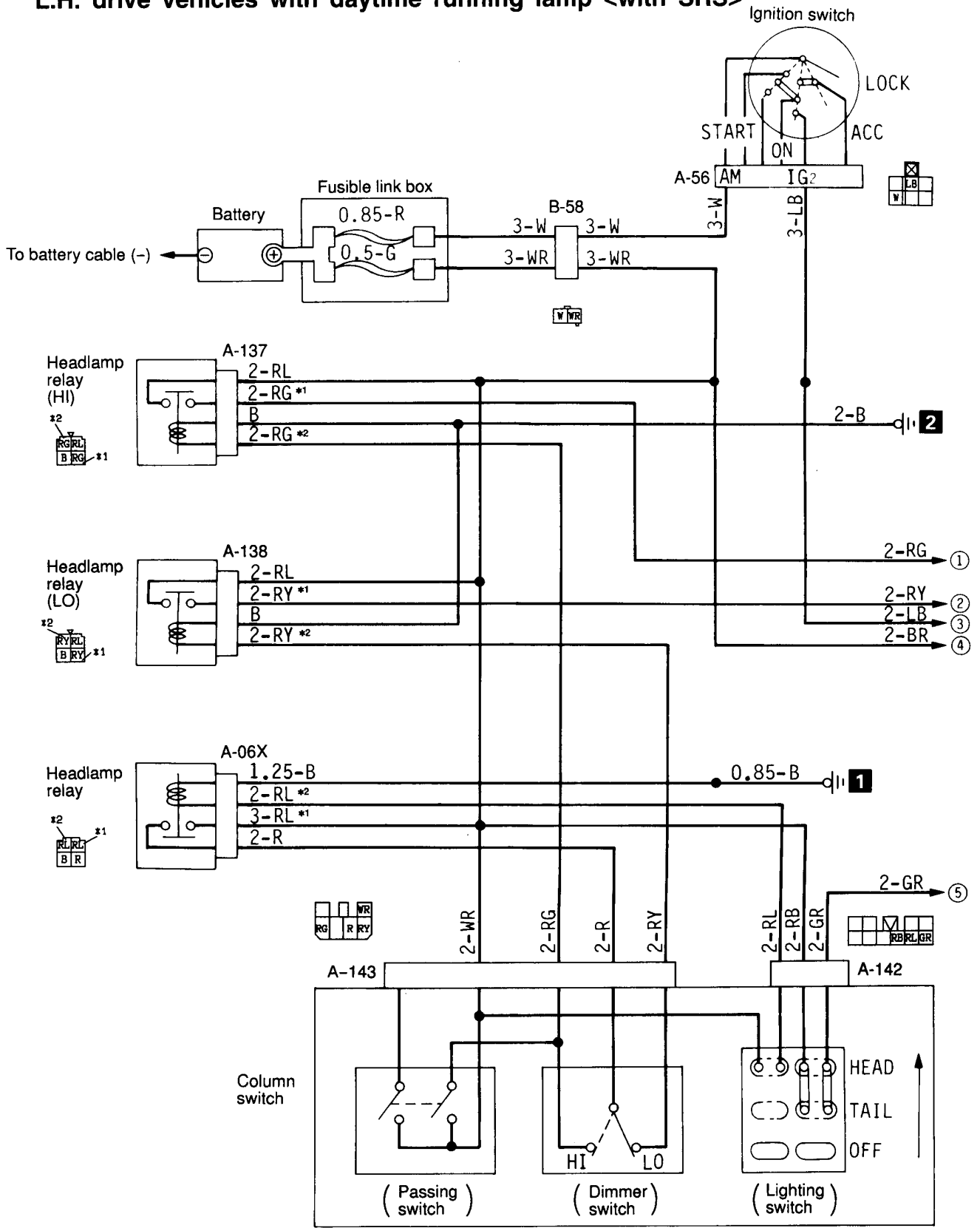

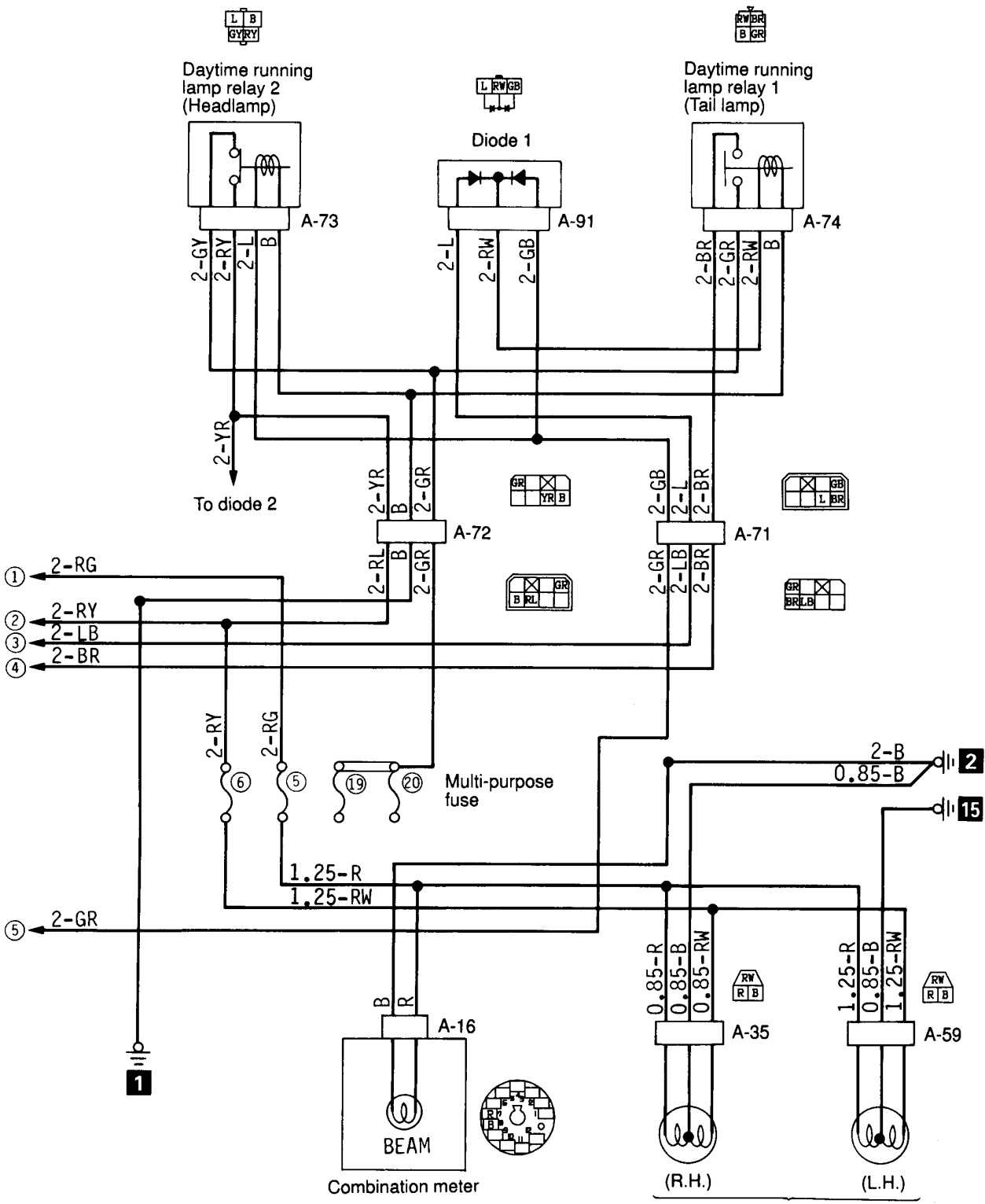

Wire colour code

B: Black	Br: Brown	G: Green	Gr: Gray	L: Blue	Lg: Light green
O: Orange	P: Pink	R: Red	Sb: Sky blue	V: Violet	W: White
					Y: Yellow

Headlamp

HEADLAMP

R.H. drive vehicles <with SRS>

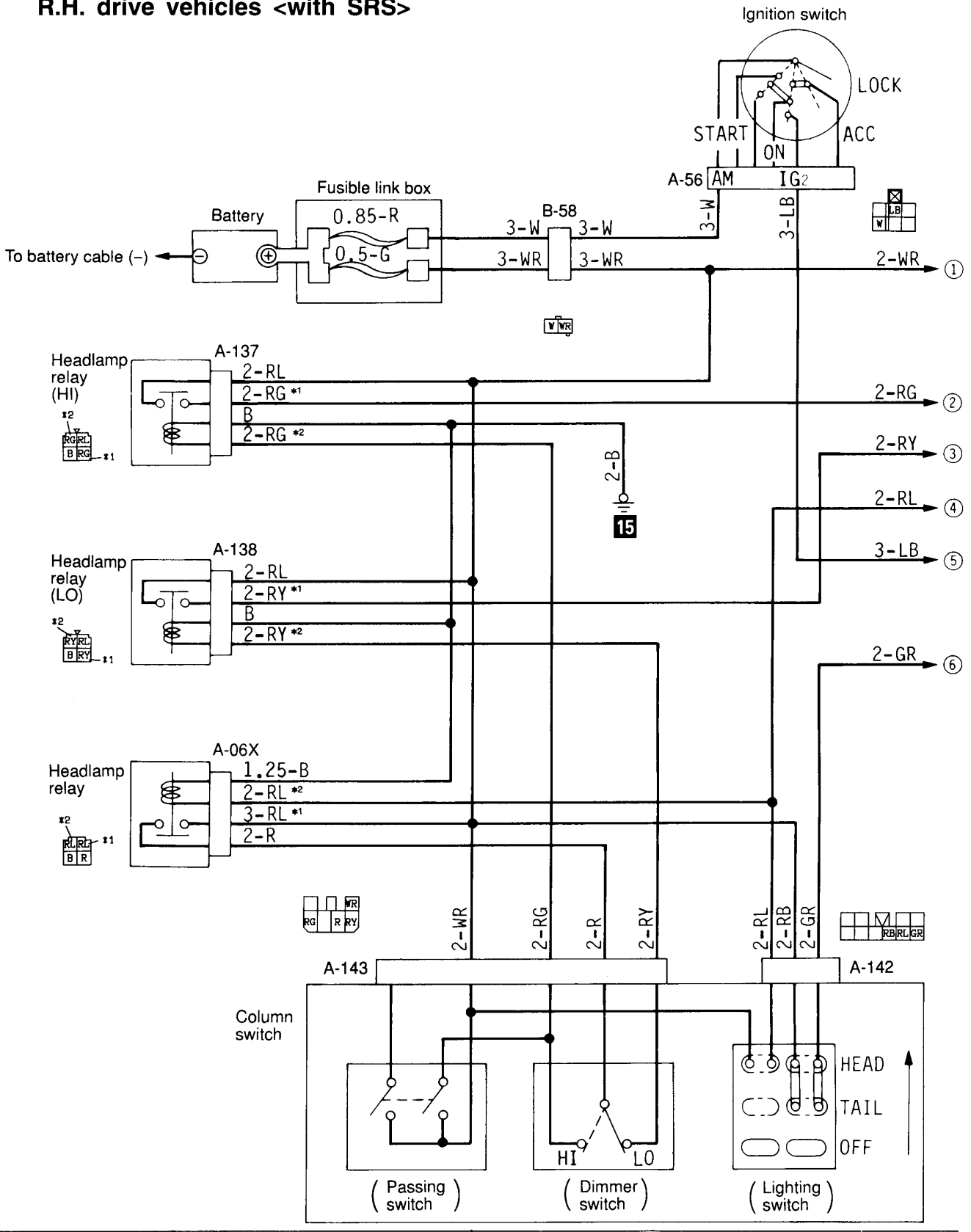

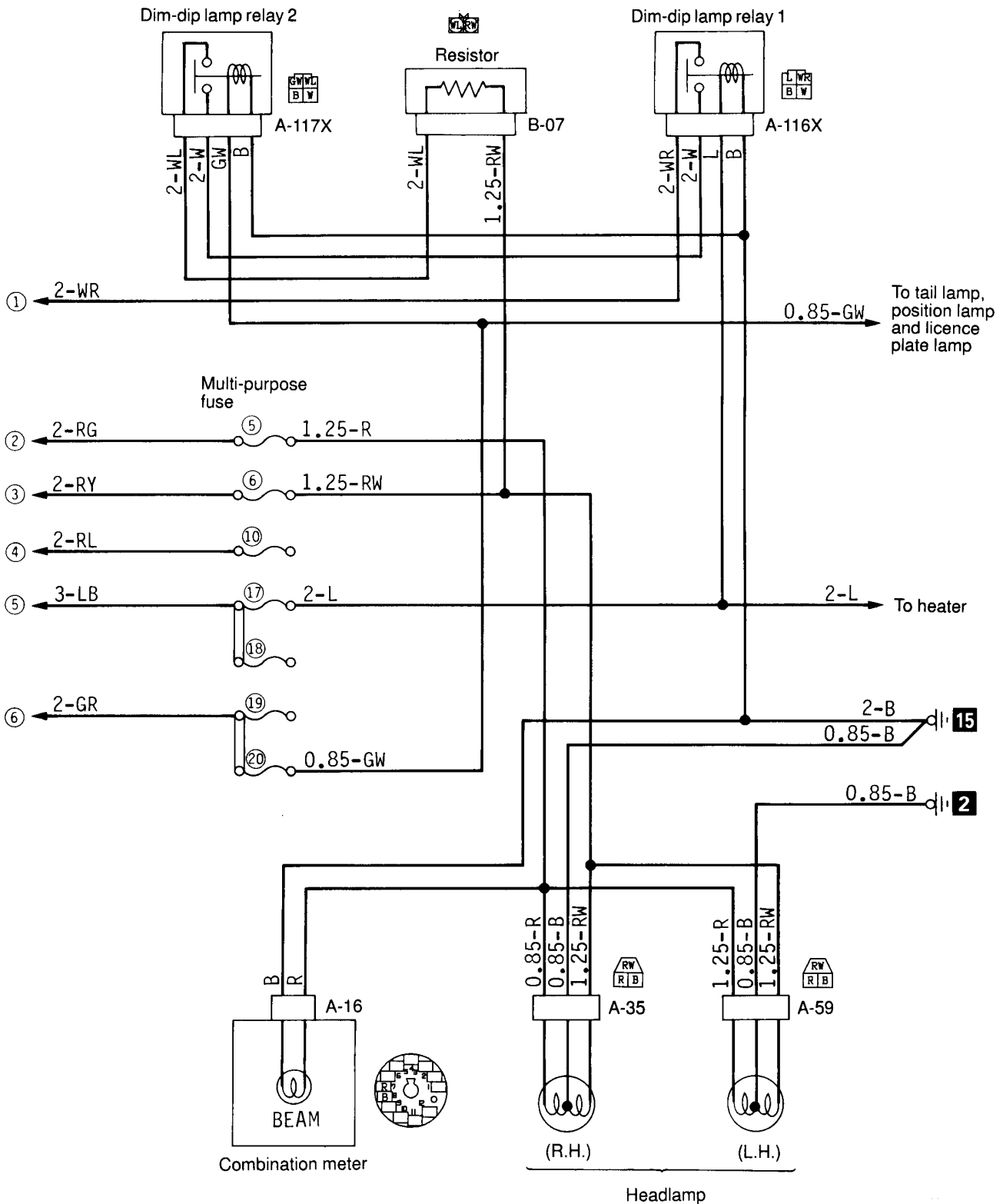

Wire colour code

B: Black Br: Brown G: Green Gr: Gray L: Blue Lg: Light green
 O: Orange P: Pink R: Red Sb: Sky blue V: Violet W: White Y: Yellow

HEADLAMP LEVELING

Vehicles with SRS

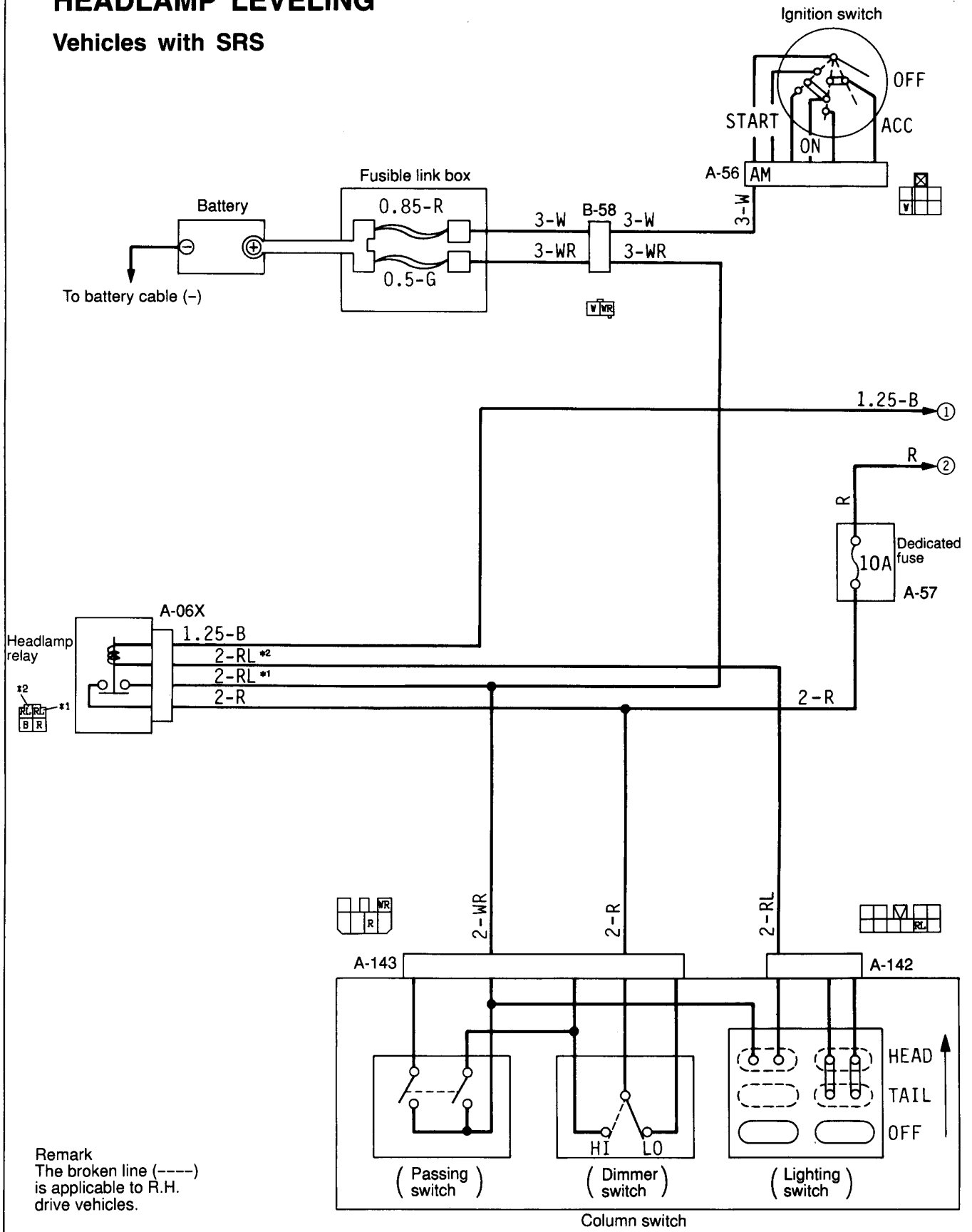

Remark
The broken line (-----)
is applicable to R.H.
drive vehicles.

Column switch

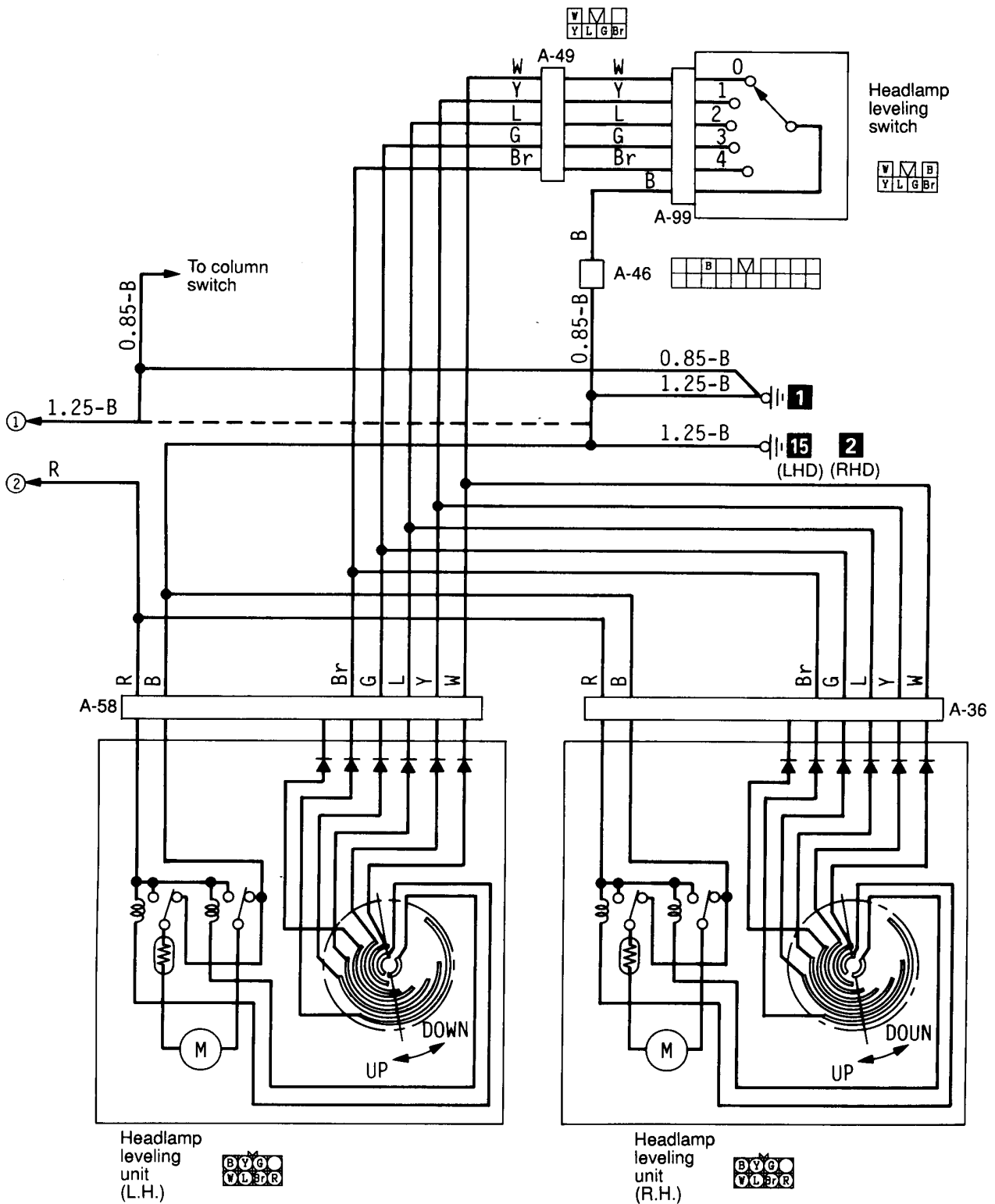

Wire colour code
 B: Black Br: Brown G: Green Gr: Gray L: Blue Lg: Light green
 O: Orange P: Pink R: Red Sb: Sky blue V: Violet W: White Y: Yellow

TAIL LAMP, POSITION LAMP AND LICENCE PLATE LAMP

Vehicles without daytime running lamp

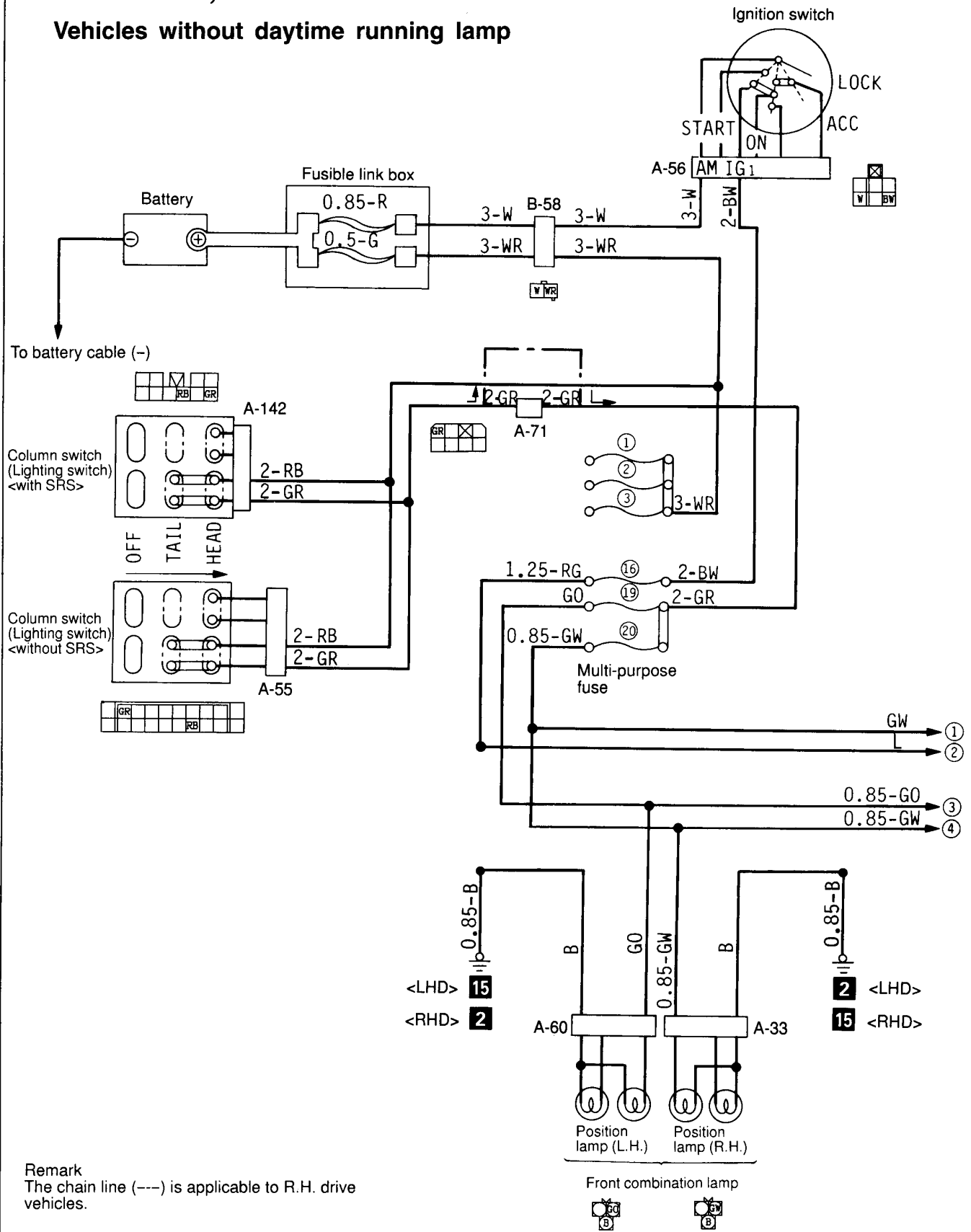

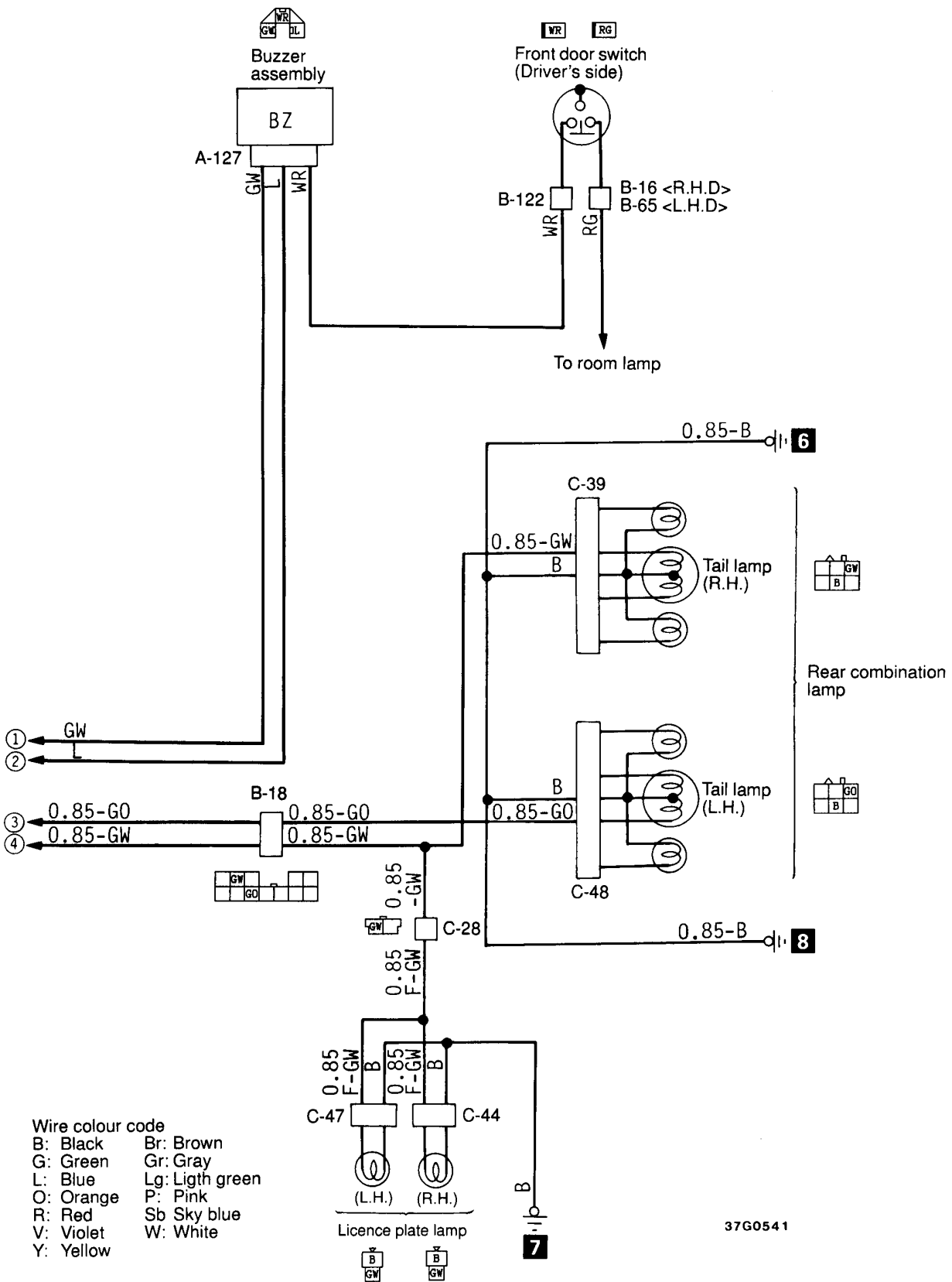

TAIL LAMP, POSITION LAMP AND LICENCE PLATE LAMP

Vehicles with daytime running lamp

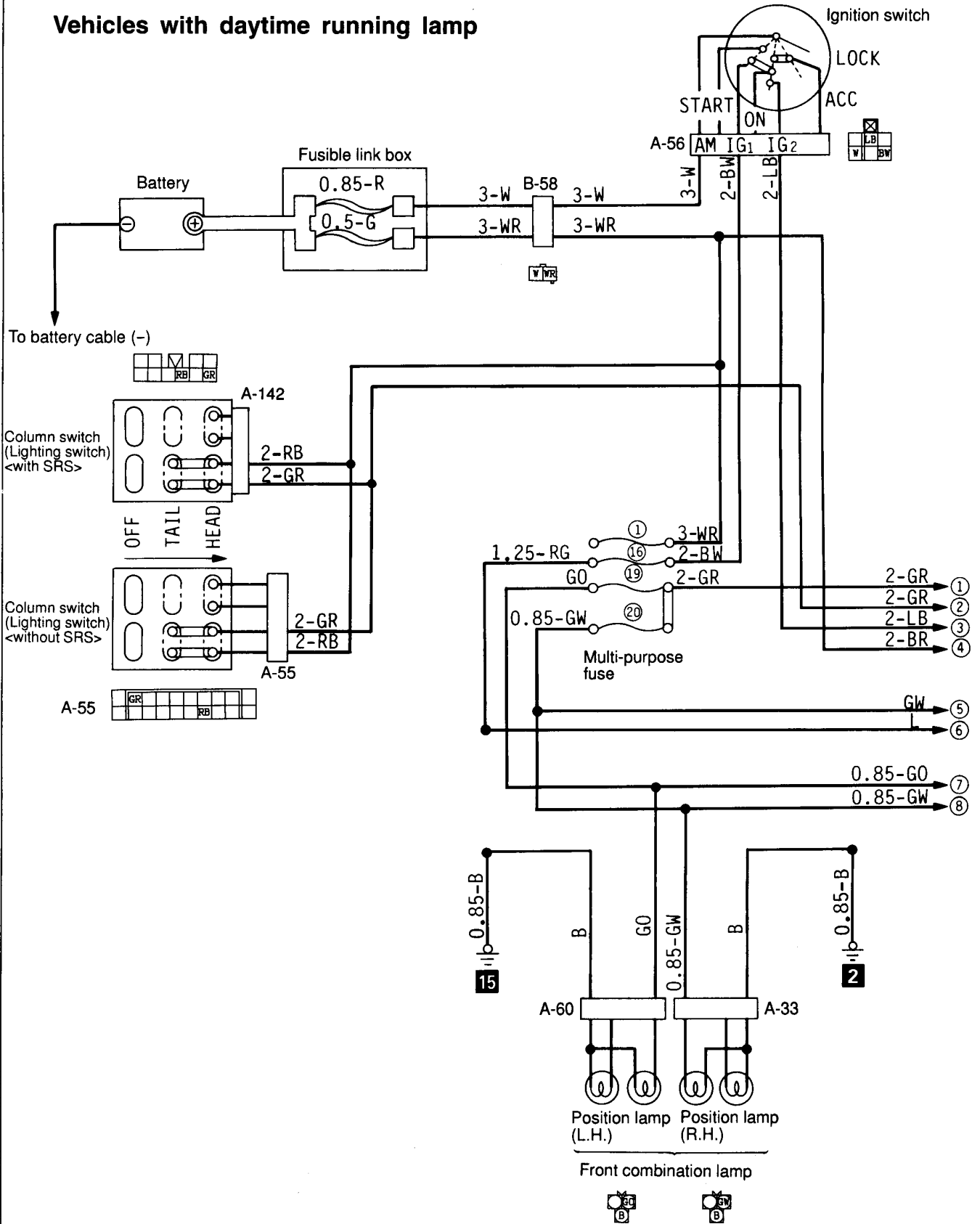

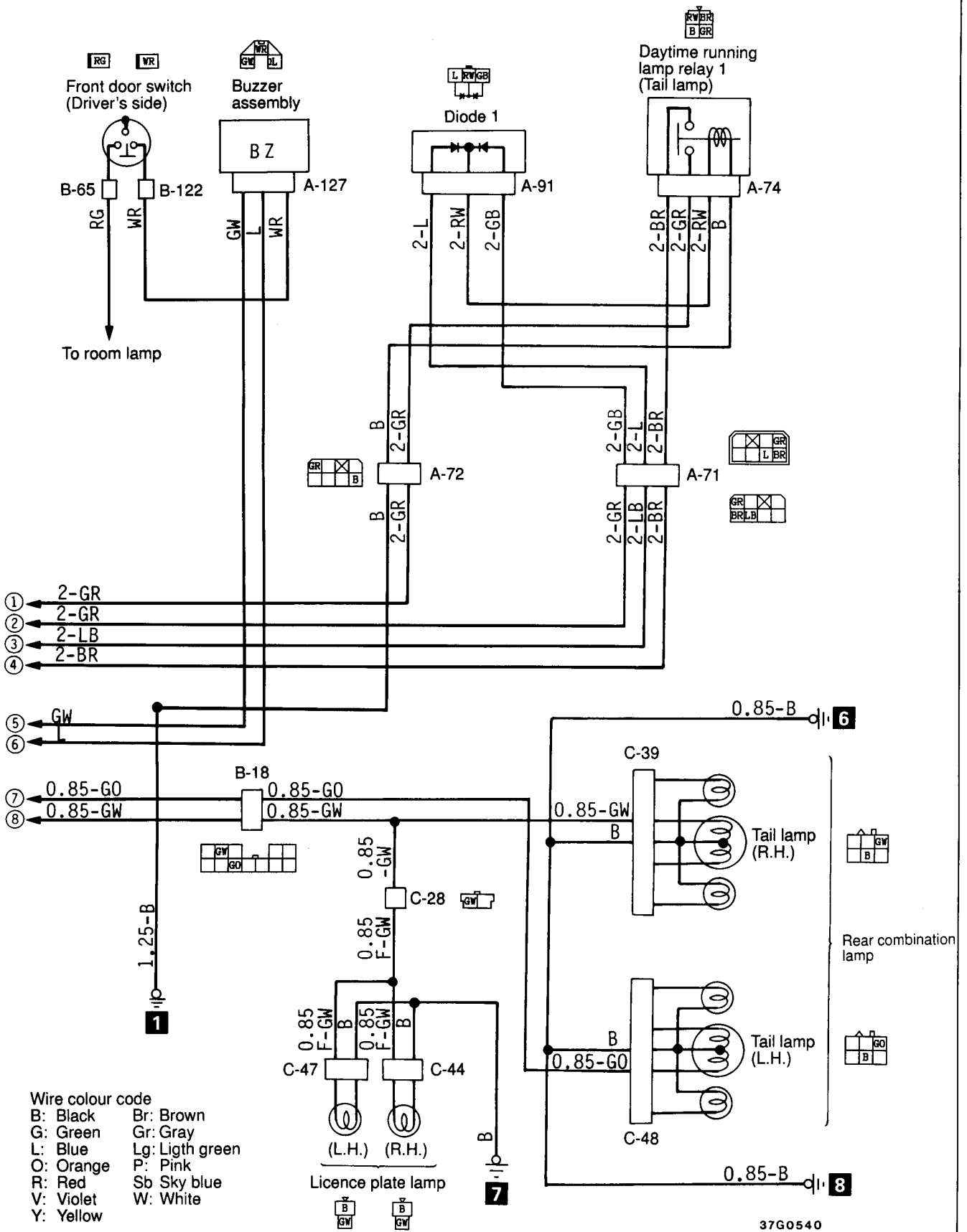

REAR FOG LAMP

L.H. drive vehicles without daytime running lamp <without SRS>

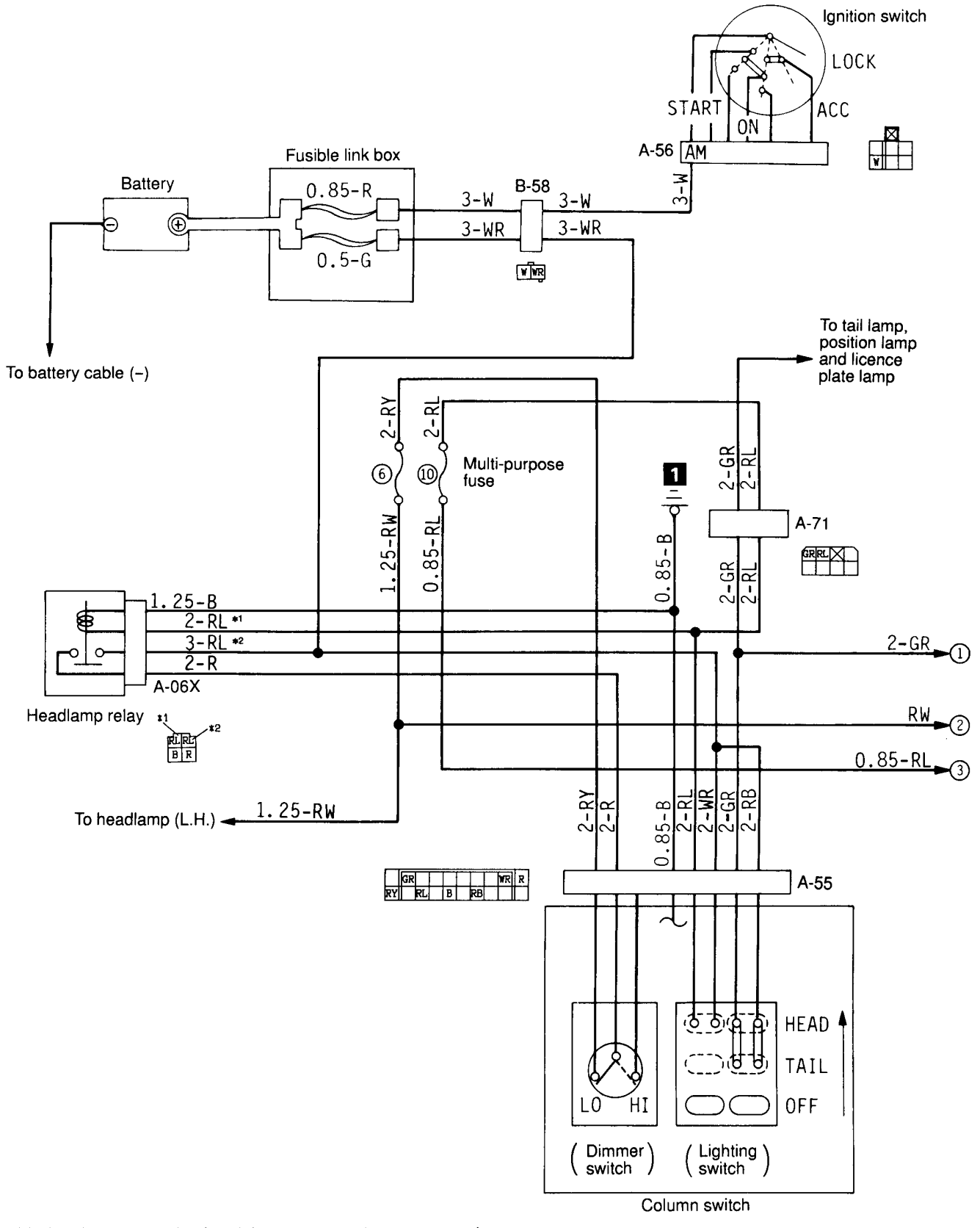

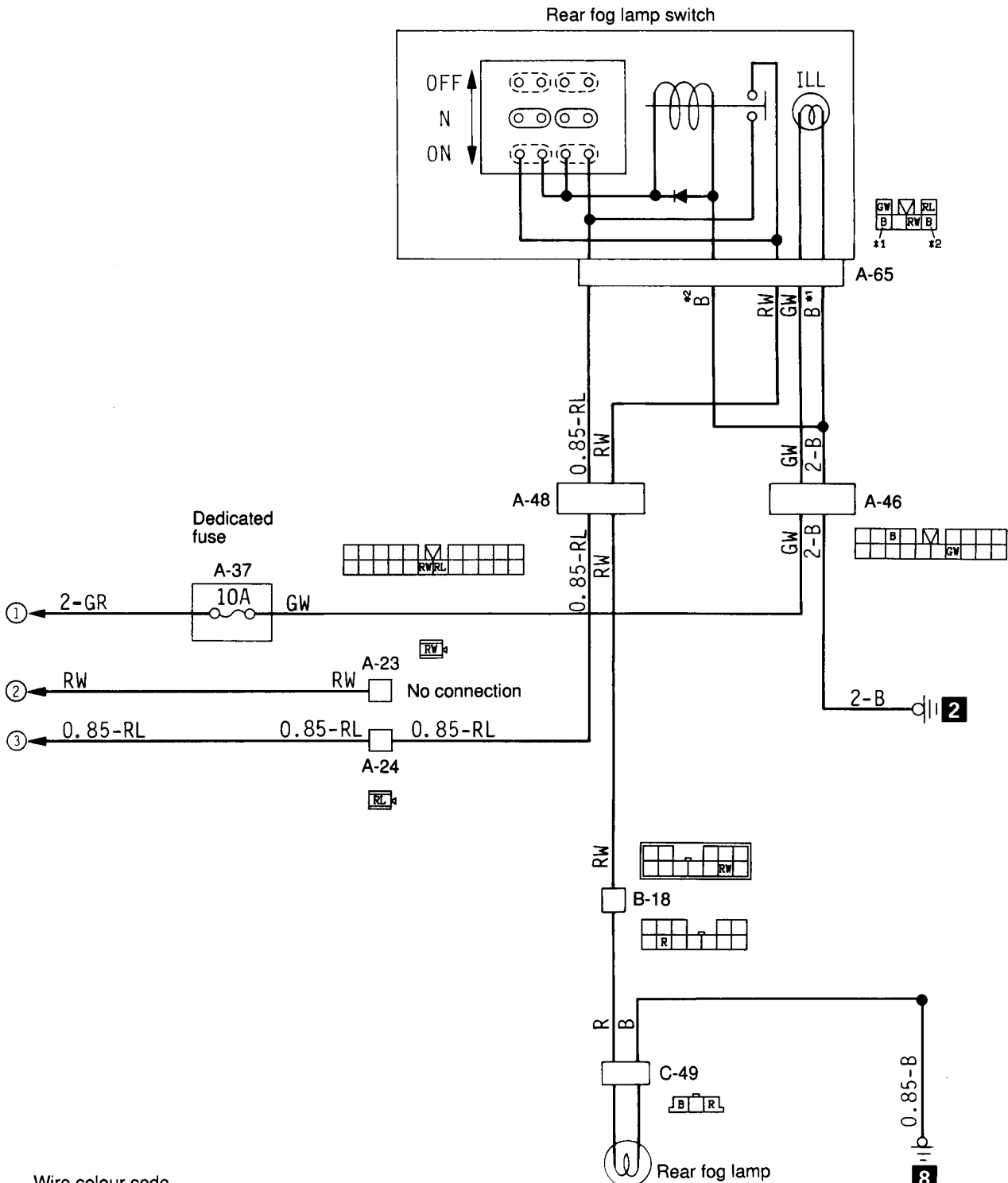

Wire colour code

B: Black Br: Brown G: Green Gr: Gray L: Blue Lg: Light green
 O: Orange P: Pink R: Red Sb: Sky blue V: Violet W: White Y: Yellow

REAR FOG LAMP

L.H. drive vehicles without daytime running lamp <with SRS>

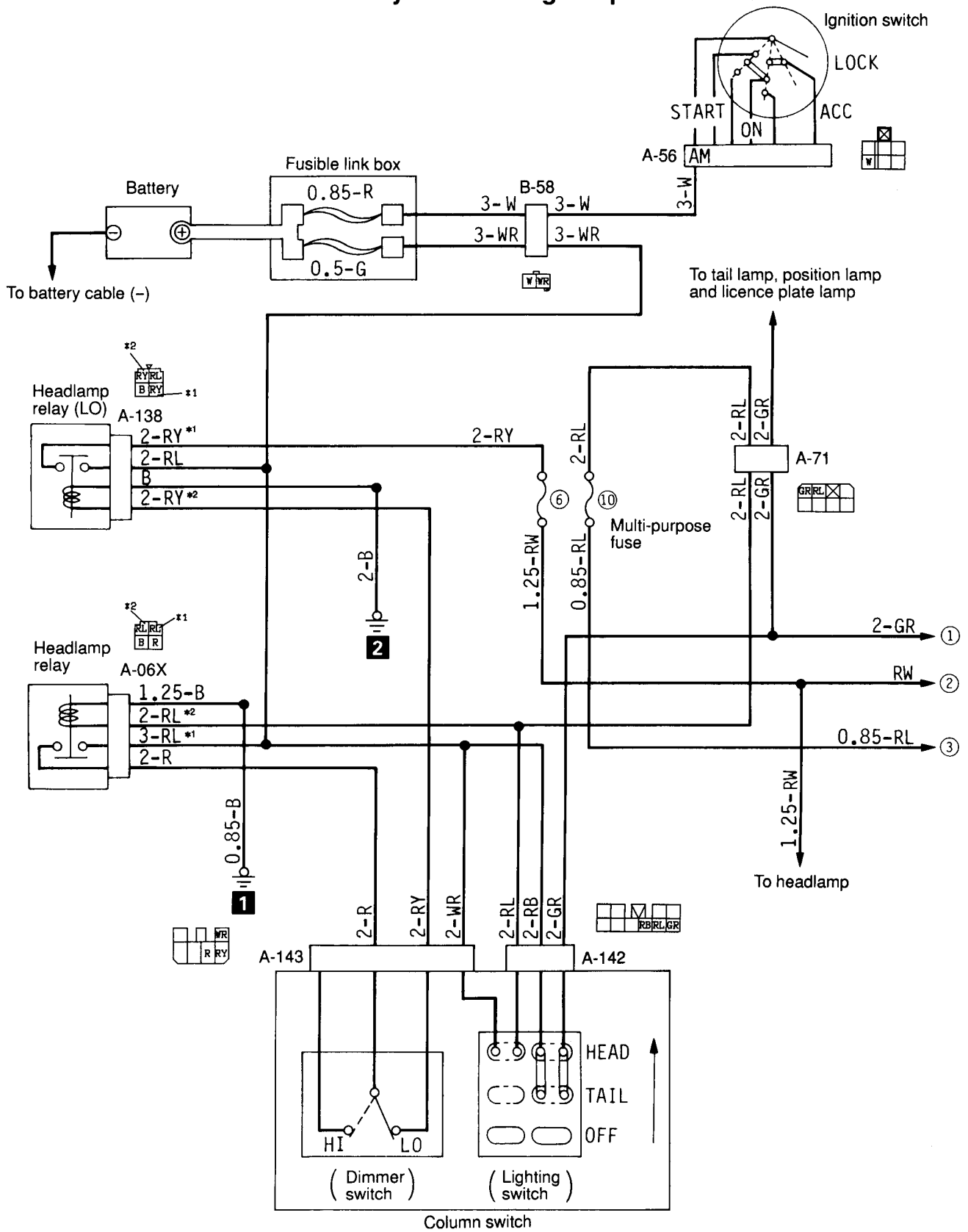

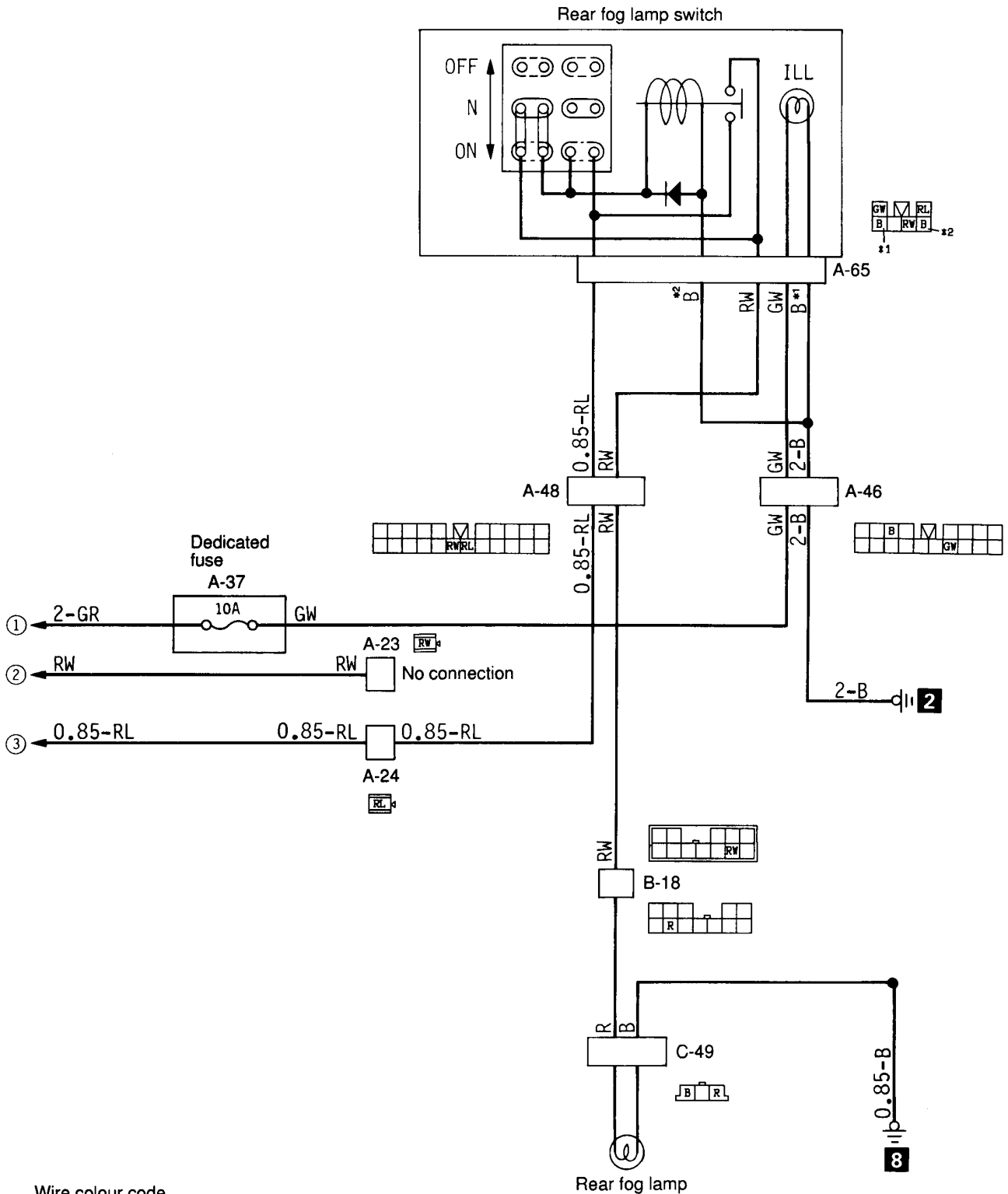

Wire colour code

B: Black Br: Brown G: Green Gr: Gray L: Blue Lg: Lighth green
 O: Orange P: Pink R: Red Sb: Sky blue V: Violet W: White Y: Yellow

37G0544

REAR FOG LAMP

L.H. drive vehicles with daytime running lamp <without SRS>

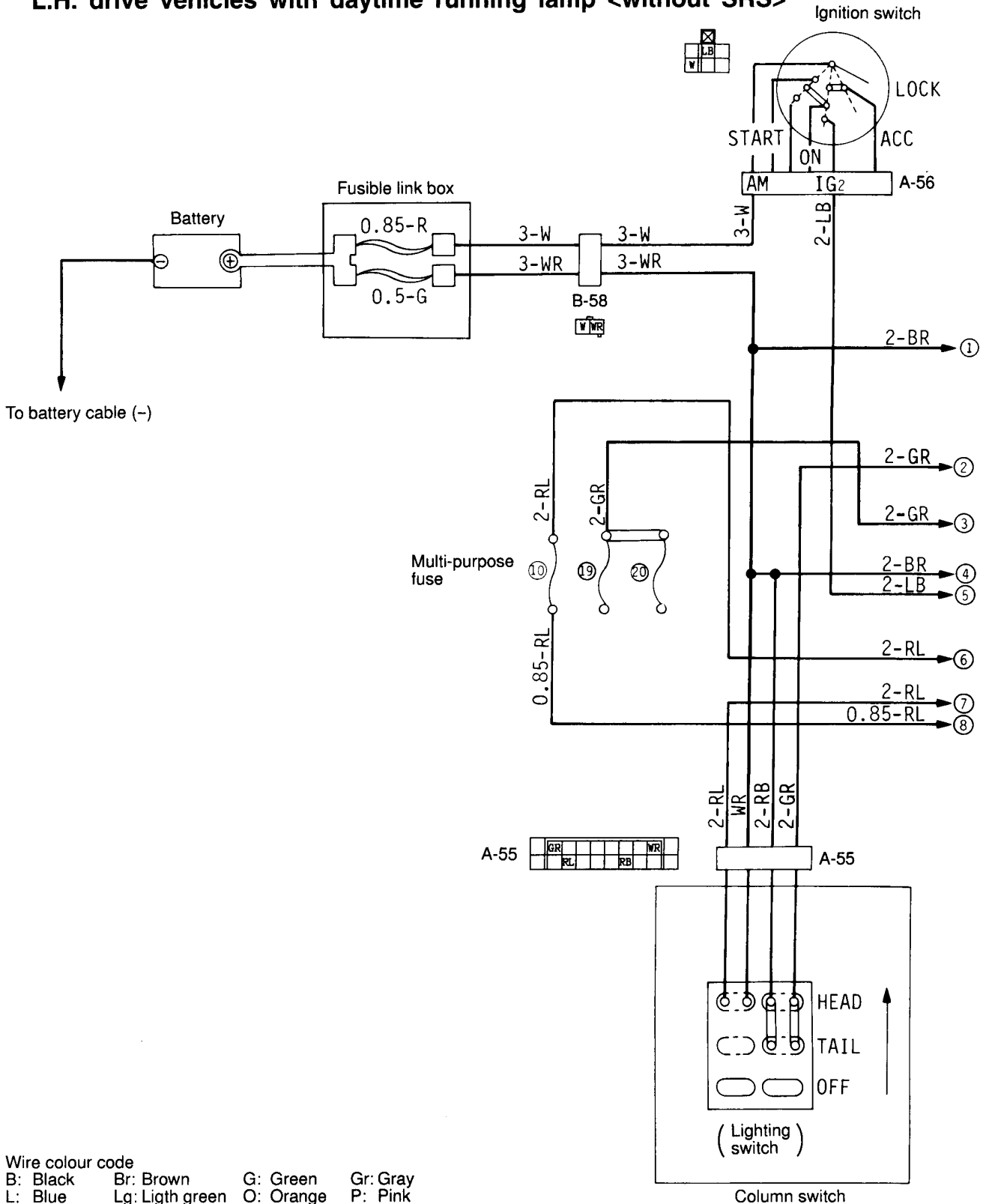

Wire colour code
 B: Black Br: Brown G: Green Gr: Gray
 L: Blue Lg: Ligth green O: Orange P: Pink
 R: Red Sb: Sky blue V: Violet W: White
 Y: Yellow

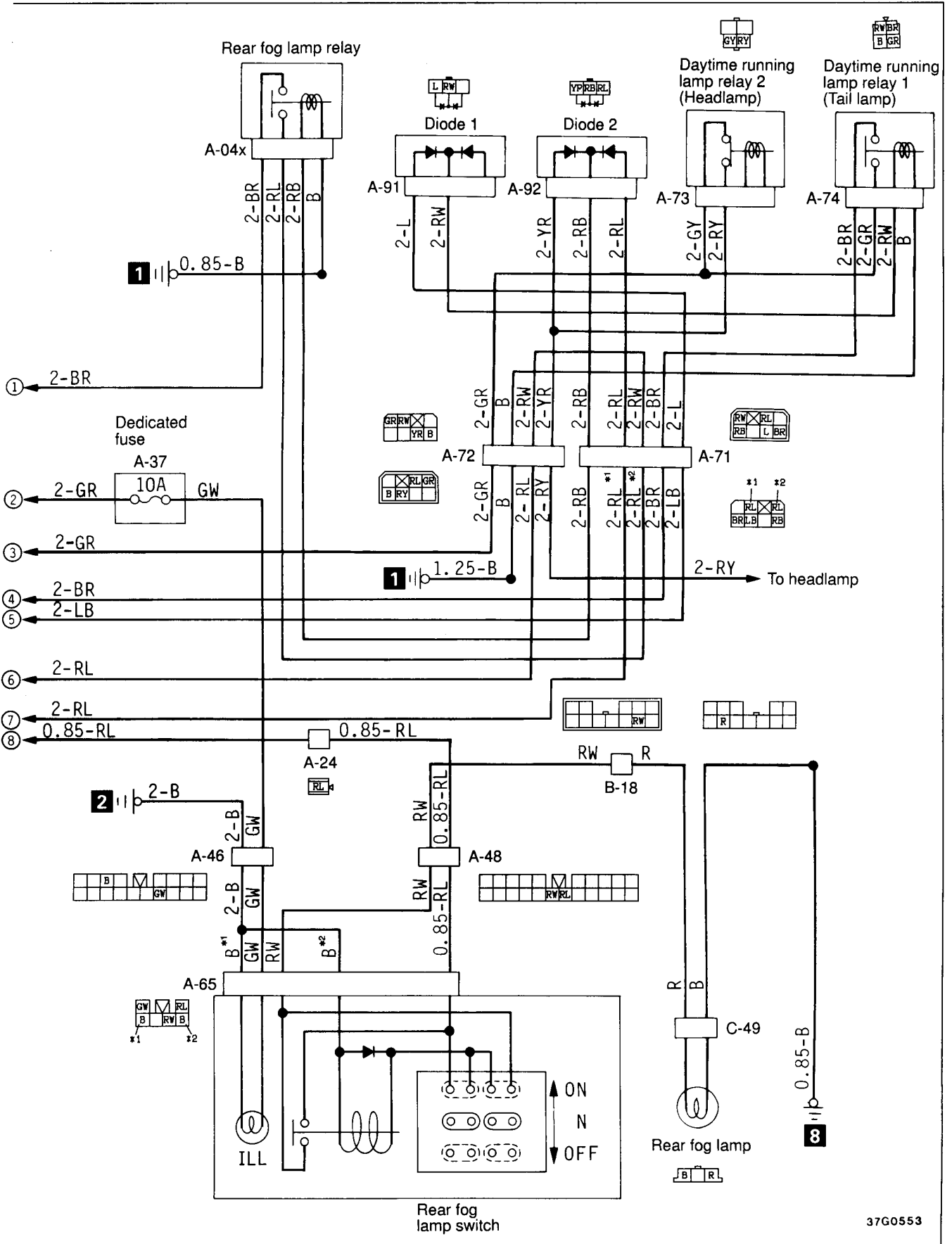

REAR FOG LAMP

L.H. drive vehicles with daytime running lamp <with SRS>

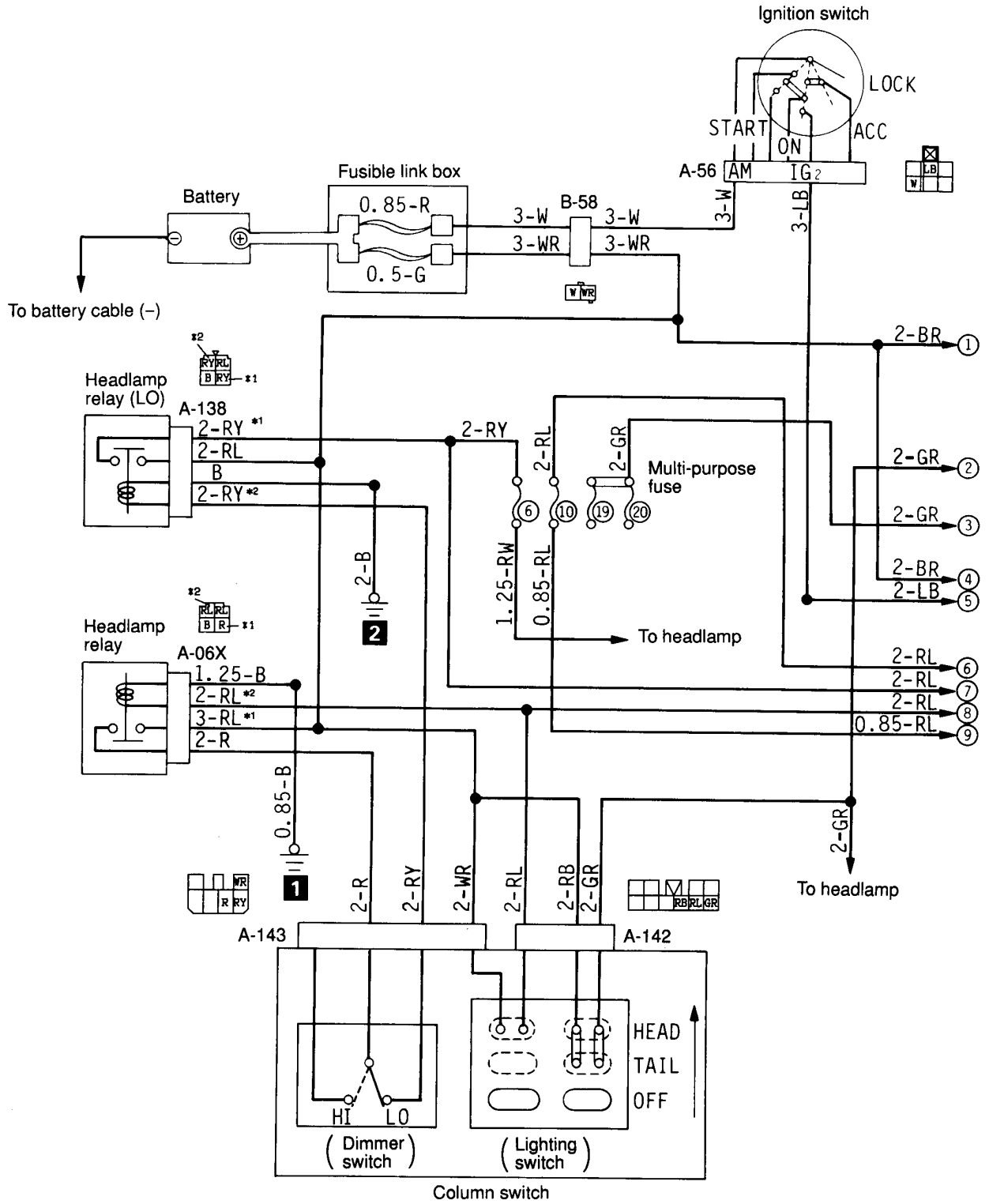

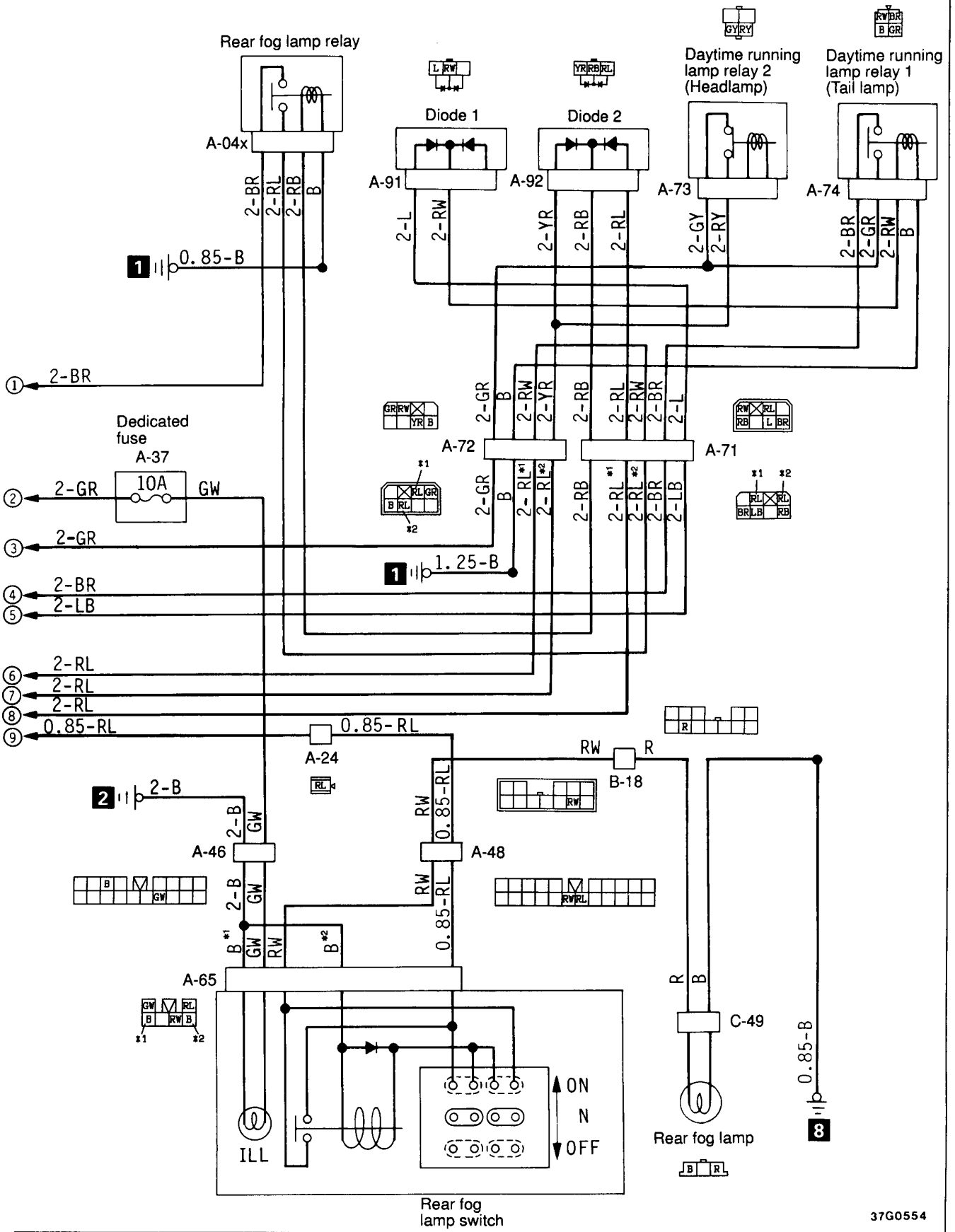

REAR FOG LAMP

R.H. drive vehicles <without SRS>

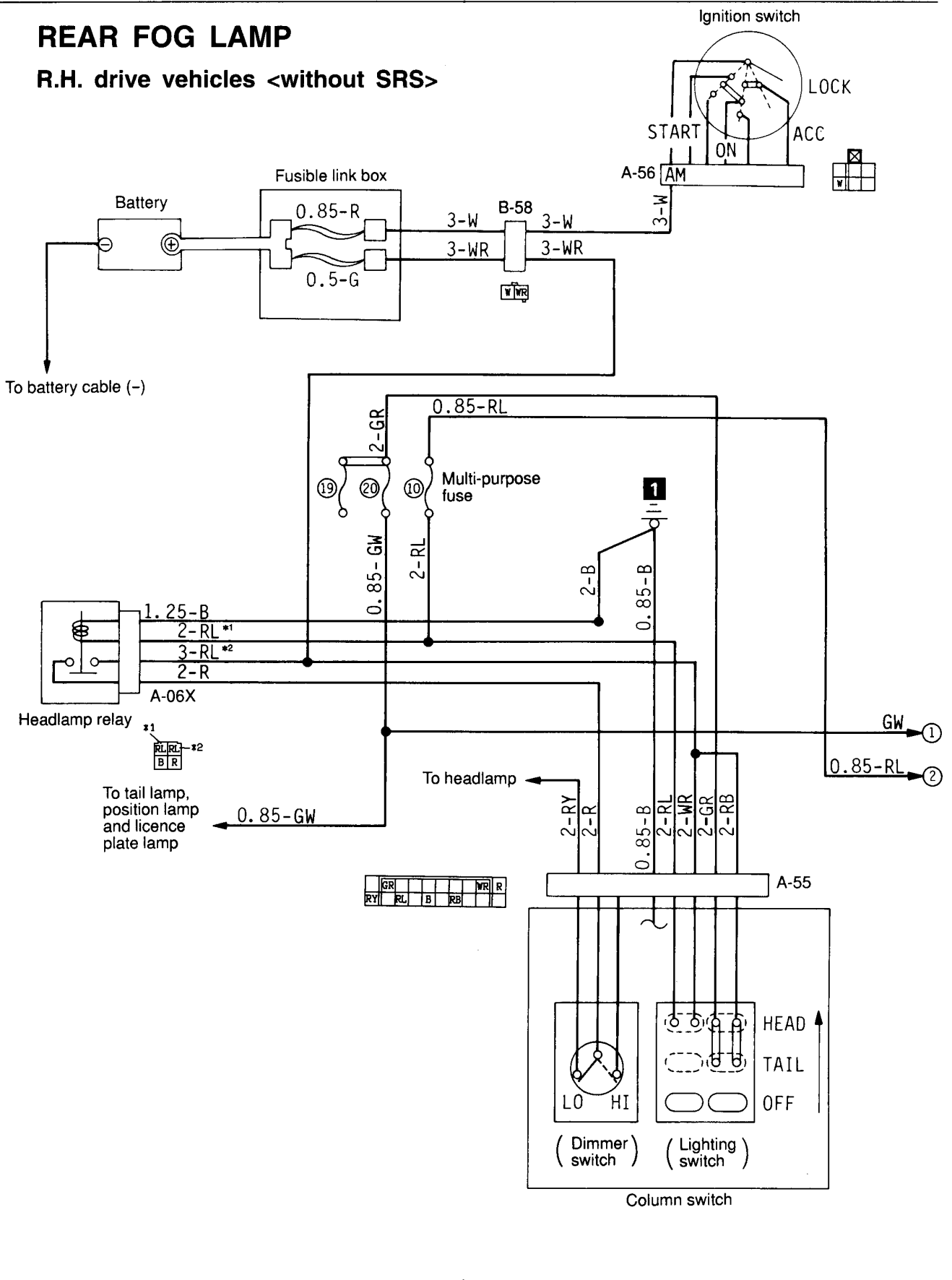

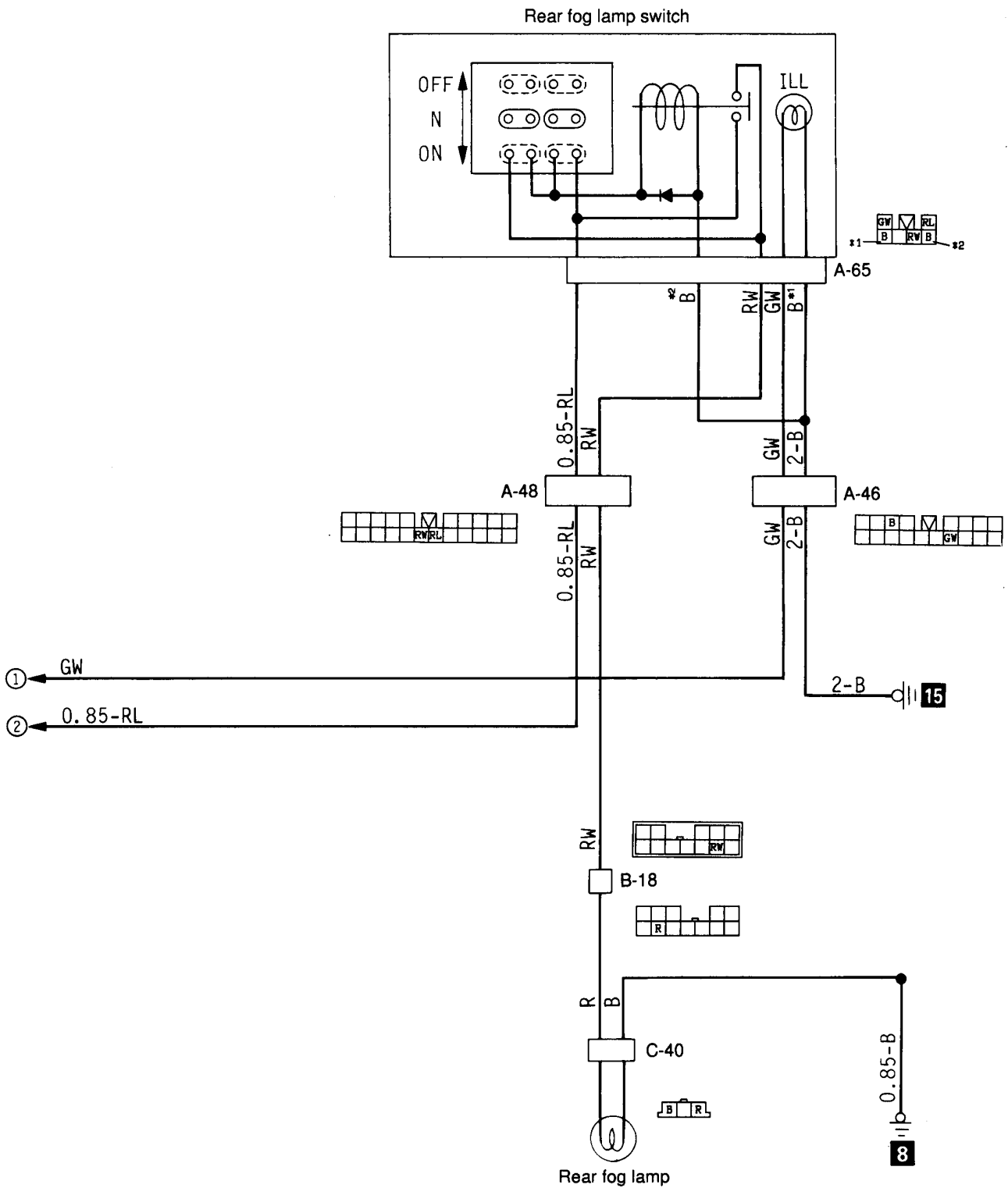

Wire colour code

B: Black Br: Brown G: Green Gr: Gray L: Blue Lg: Light green
 O: Orange P: Pink R: Red Sb: Sky blue V: Violet W: White Y: Yellow

37G0557

REAR FOG LAMP

R.H. drive vehicles <with SRS>

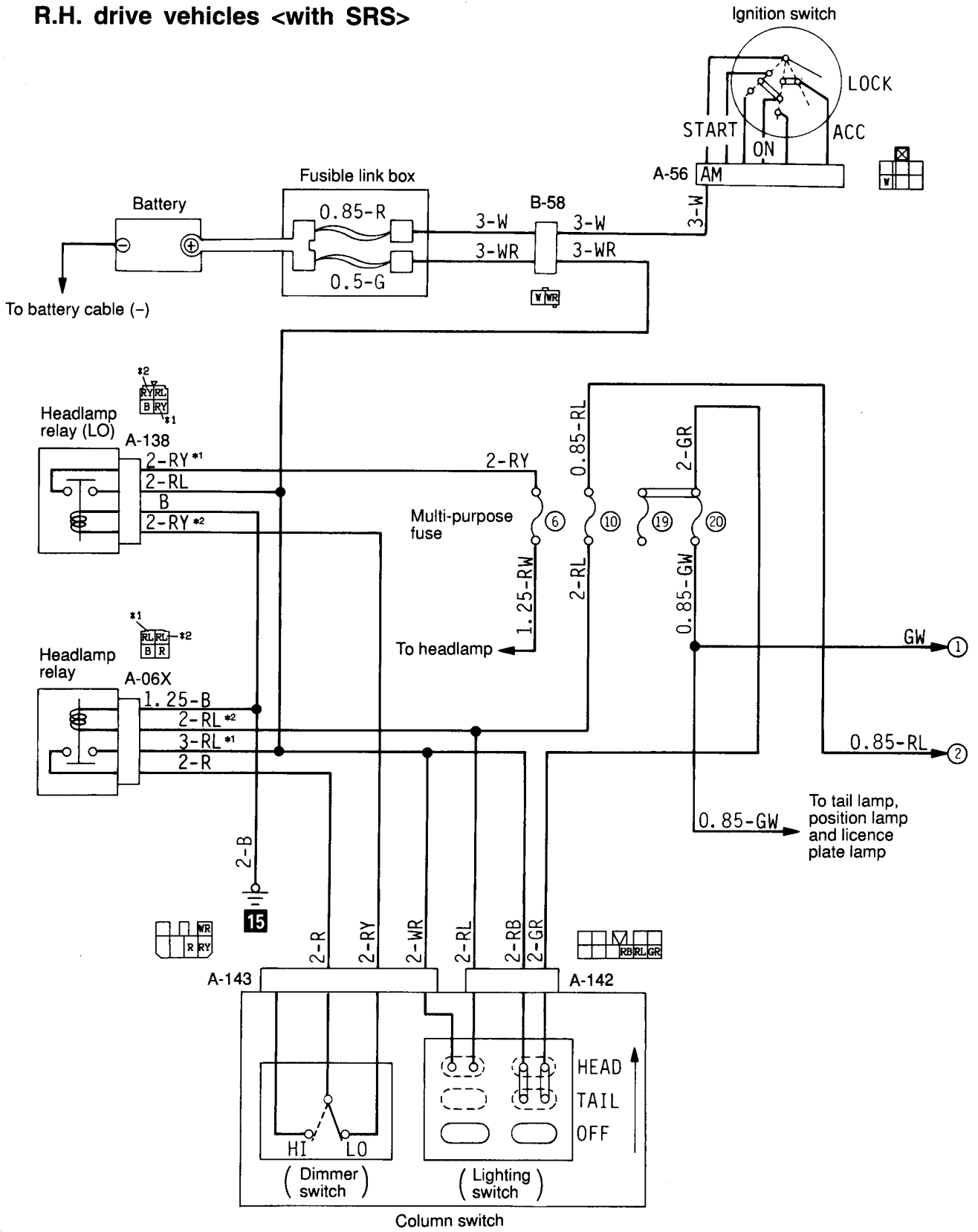

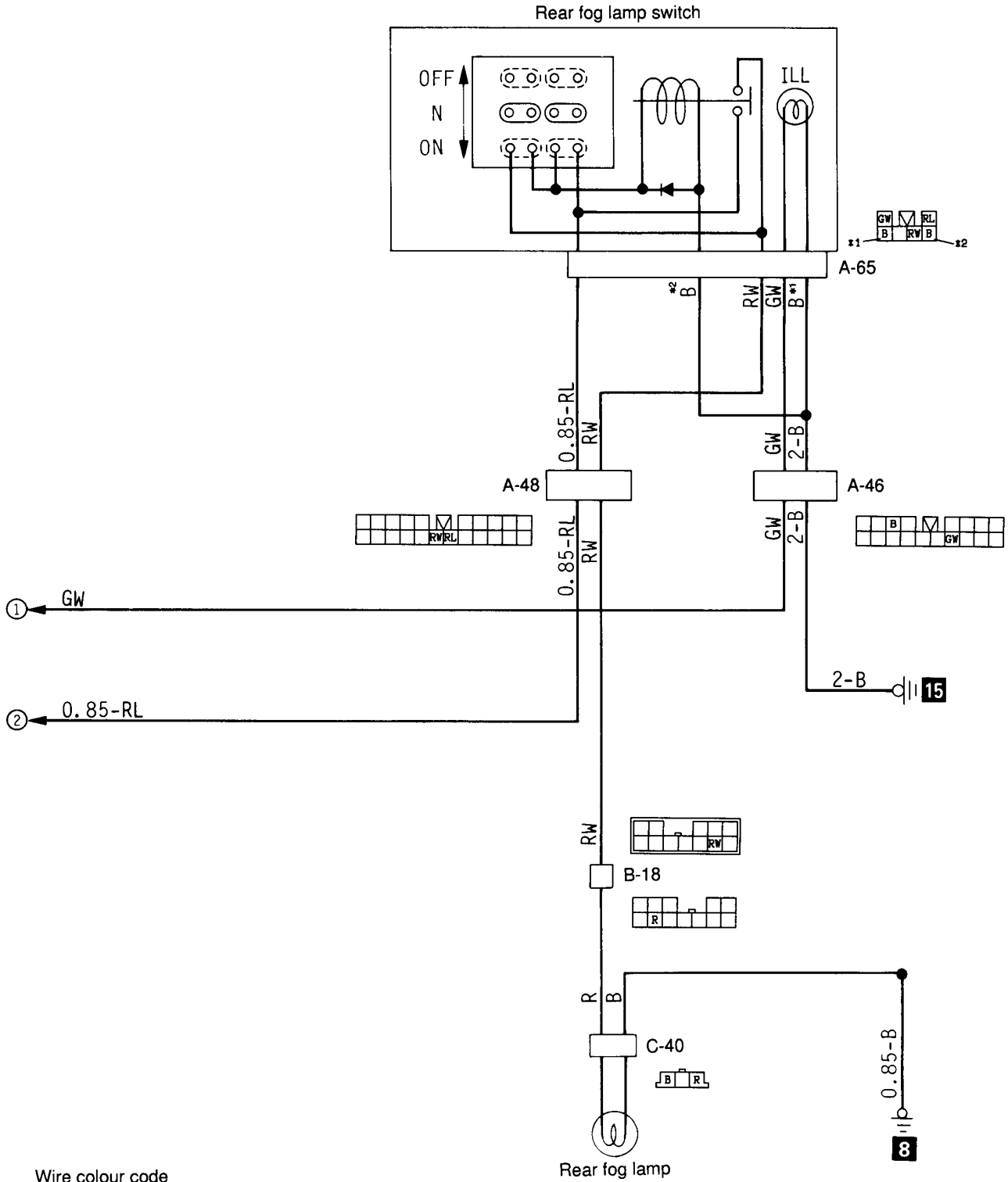

ILLUMINATION LAMP

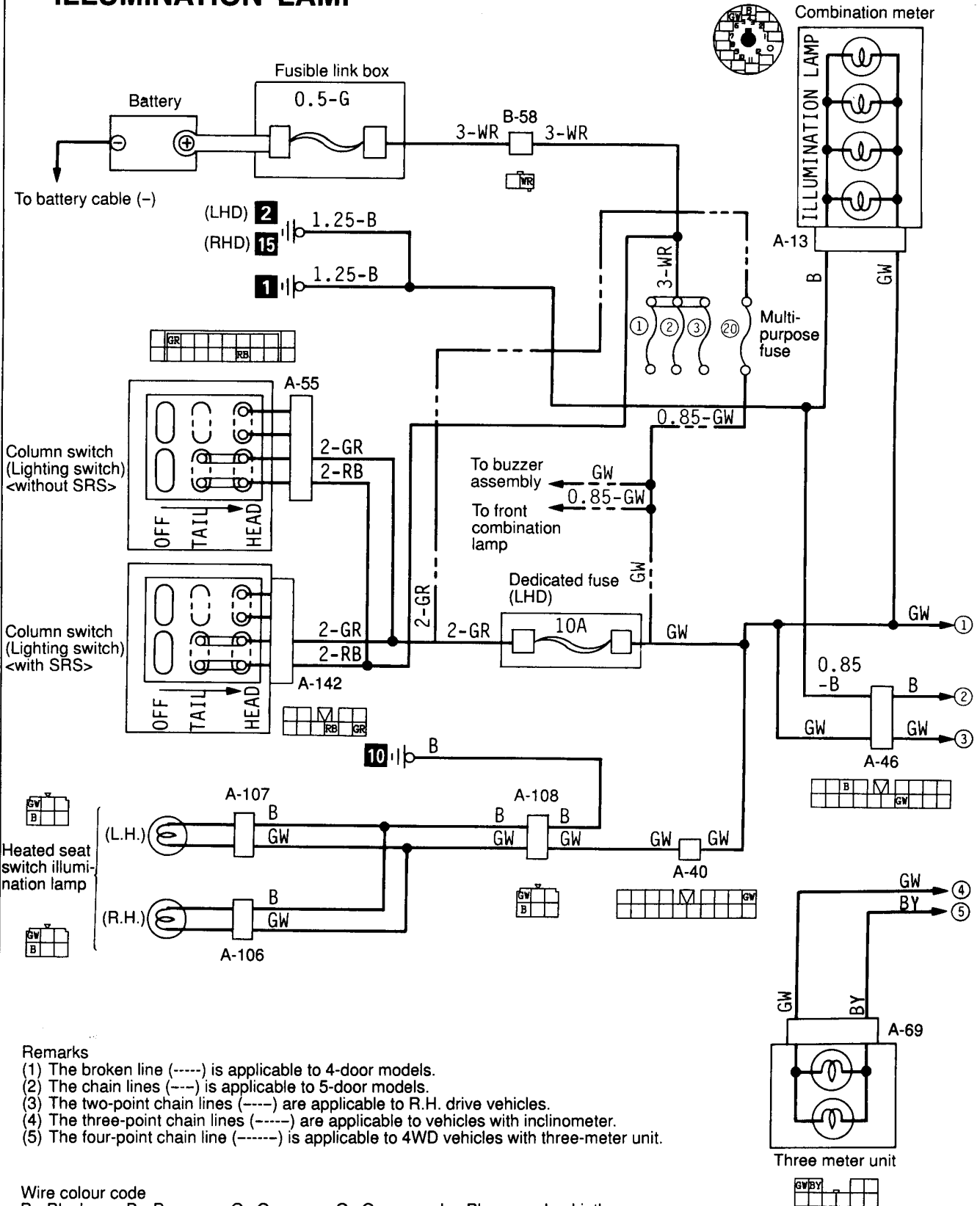

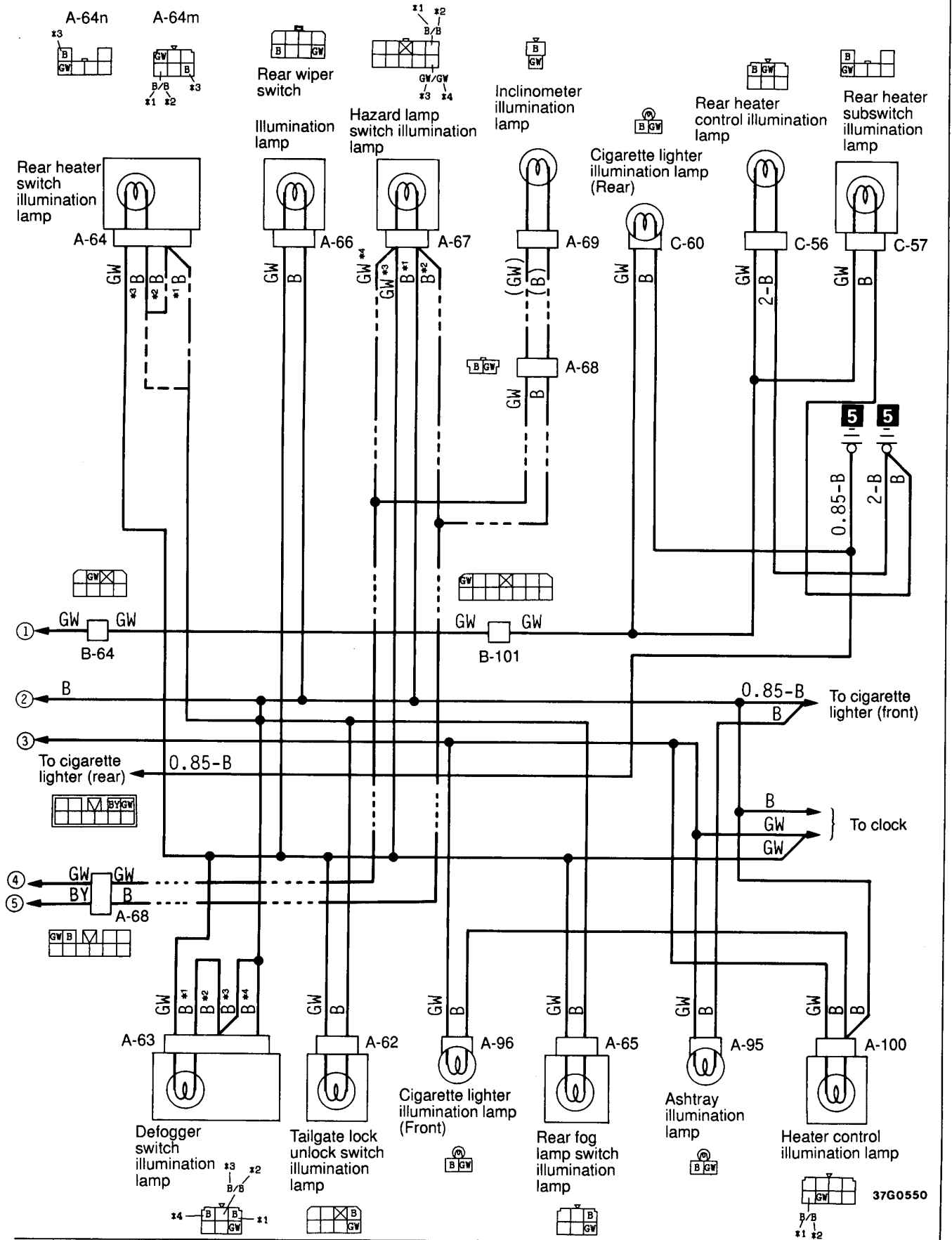

TURN-SIGNAL LAMP AND HAZARD LAMP

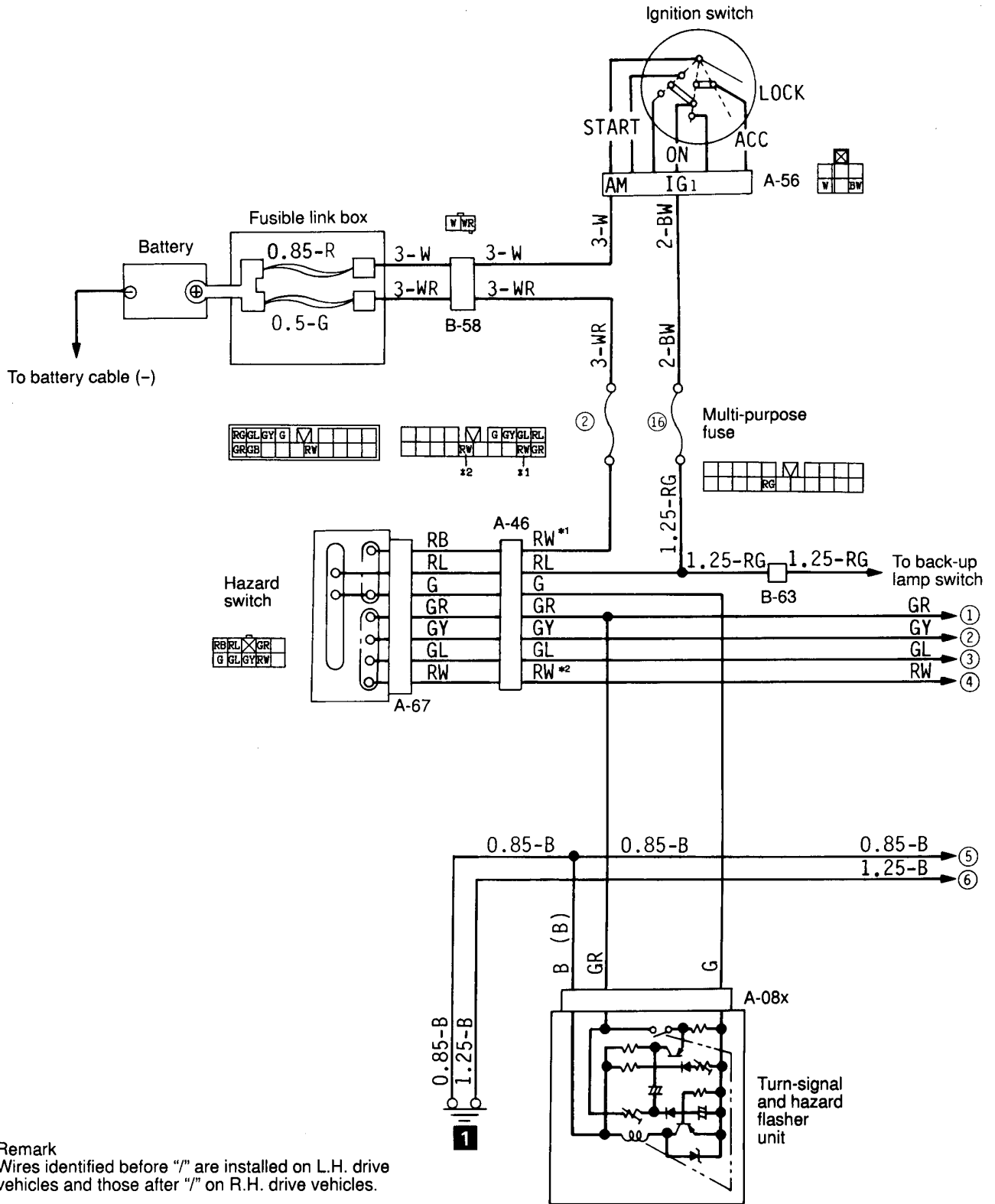

Remark
Wires identified before "/" are installed on L.H. drive vehicles and those after "/" on R.H. drive vehicles.

Wire colour code

B: Black Br: Brown G: Green Gr: Gray L: Blue Lg: Ligth green
 O: Orange P: Pink R: Red Sb: Sky blue V: Violet W: White Y: Yellow

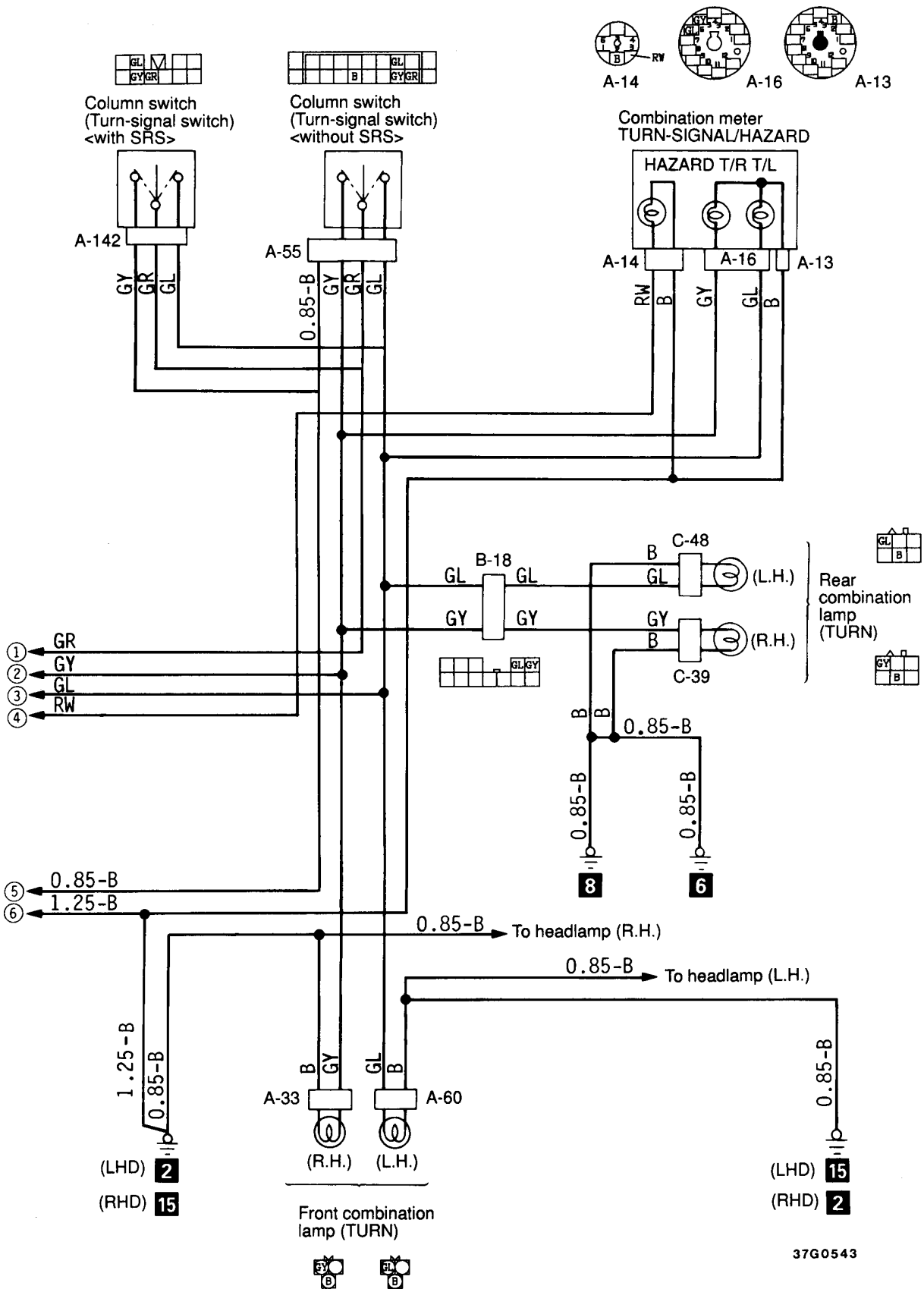

STOP LAMP

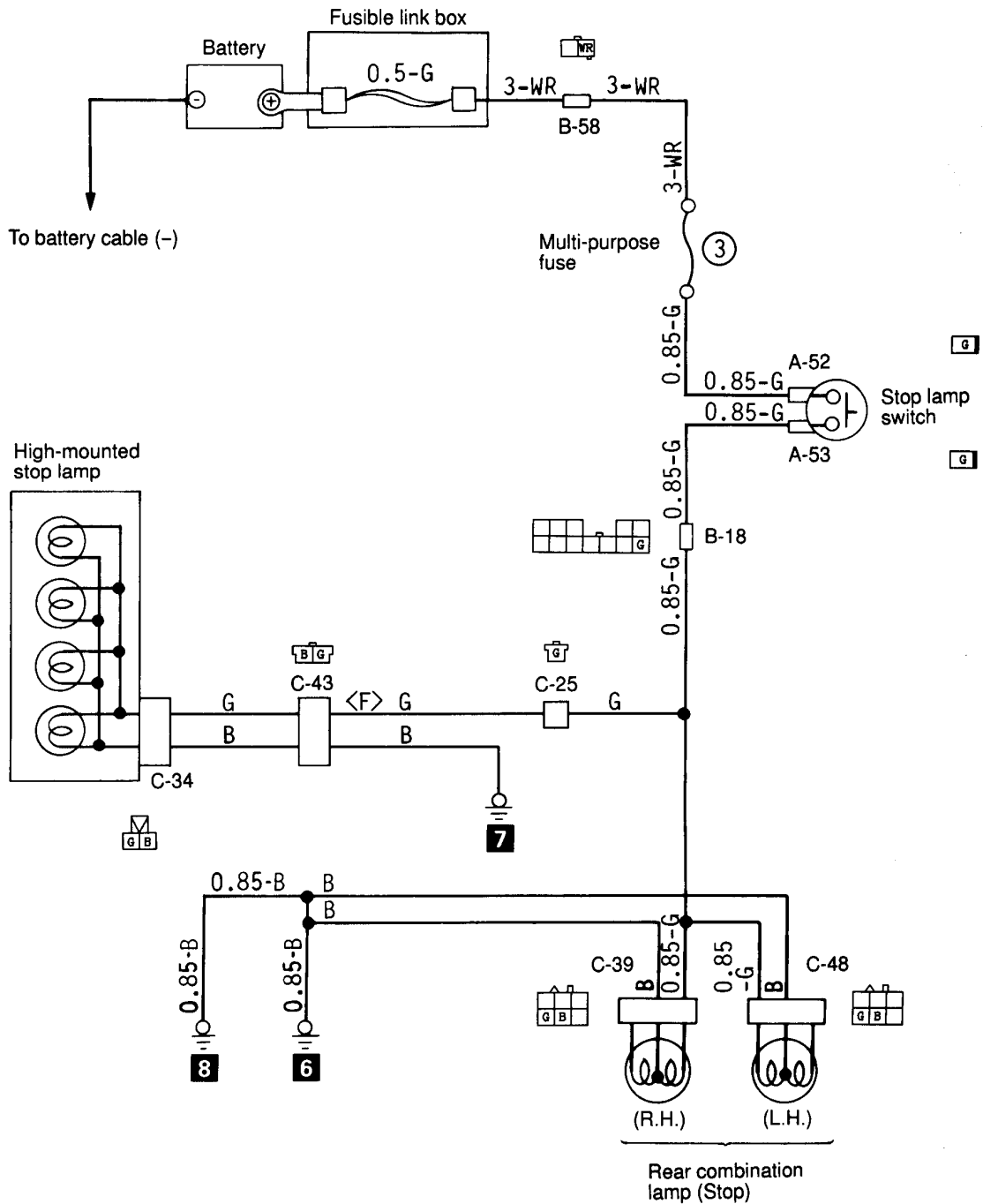

37G0538

Wire colour code

B: Black Br: Brown G: Green Gr: Gray L: Blue Lg: Ligth green
 O: Orange P: Pink R: Red Sb: Sky blue V: Violet W: White Y: Yellow

HORN

Vehicles with SRS

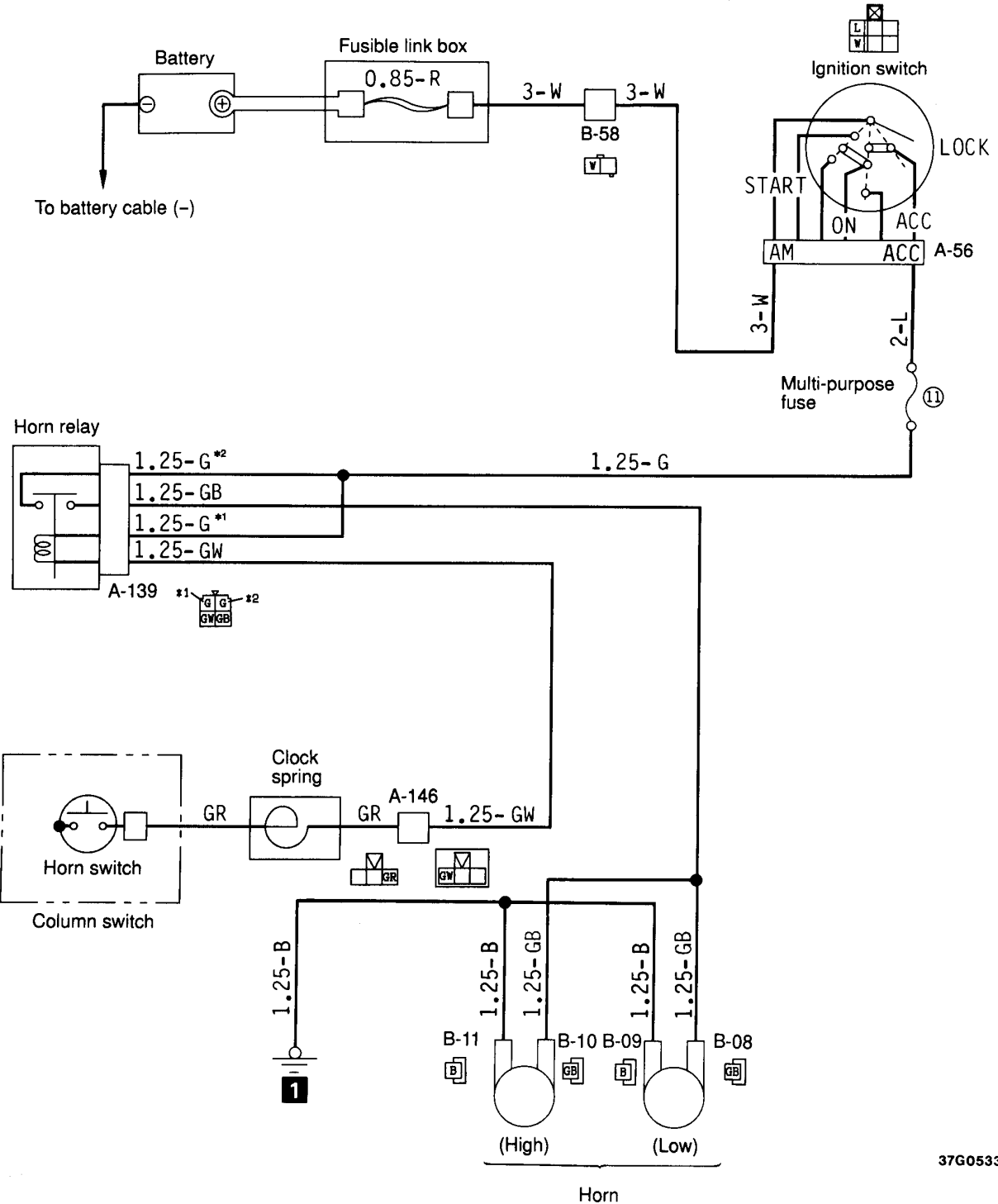

37G0533

Wire colour code

B: Black Br: Brown G: Green Gr: Gray L: Blue Lg: Light green
 O: Orange P: Pink R: Red Sb: Sky blue V: Violet W: White Y: Yellow

WIPER AND WASHER

Vehicles with SRS

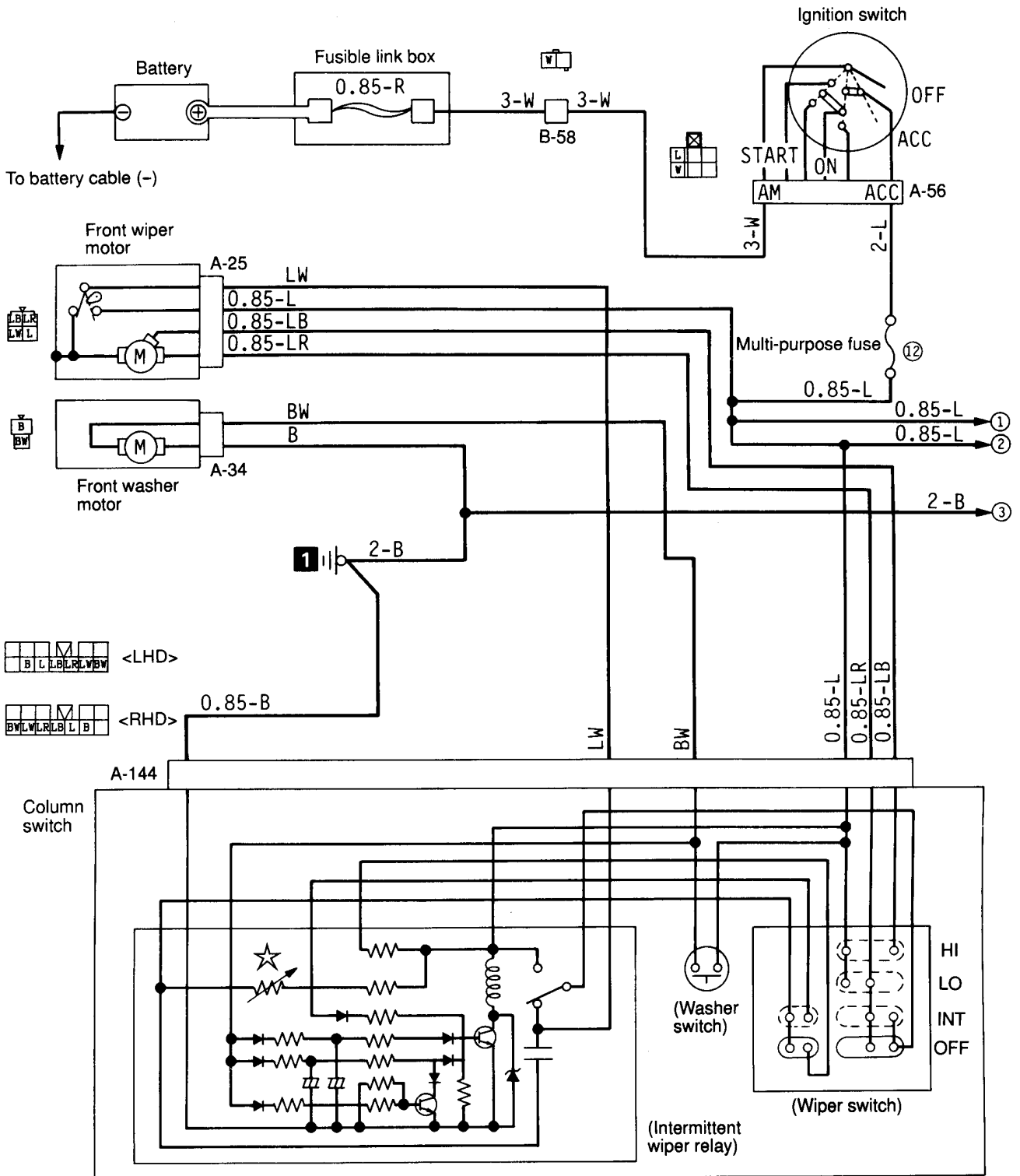

Remark
 The ☆ symbol for the intermittent wiper relay indicates applicability to variable intermittent wipers.

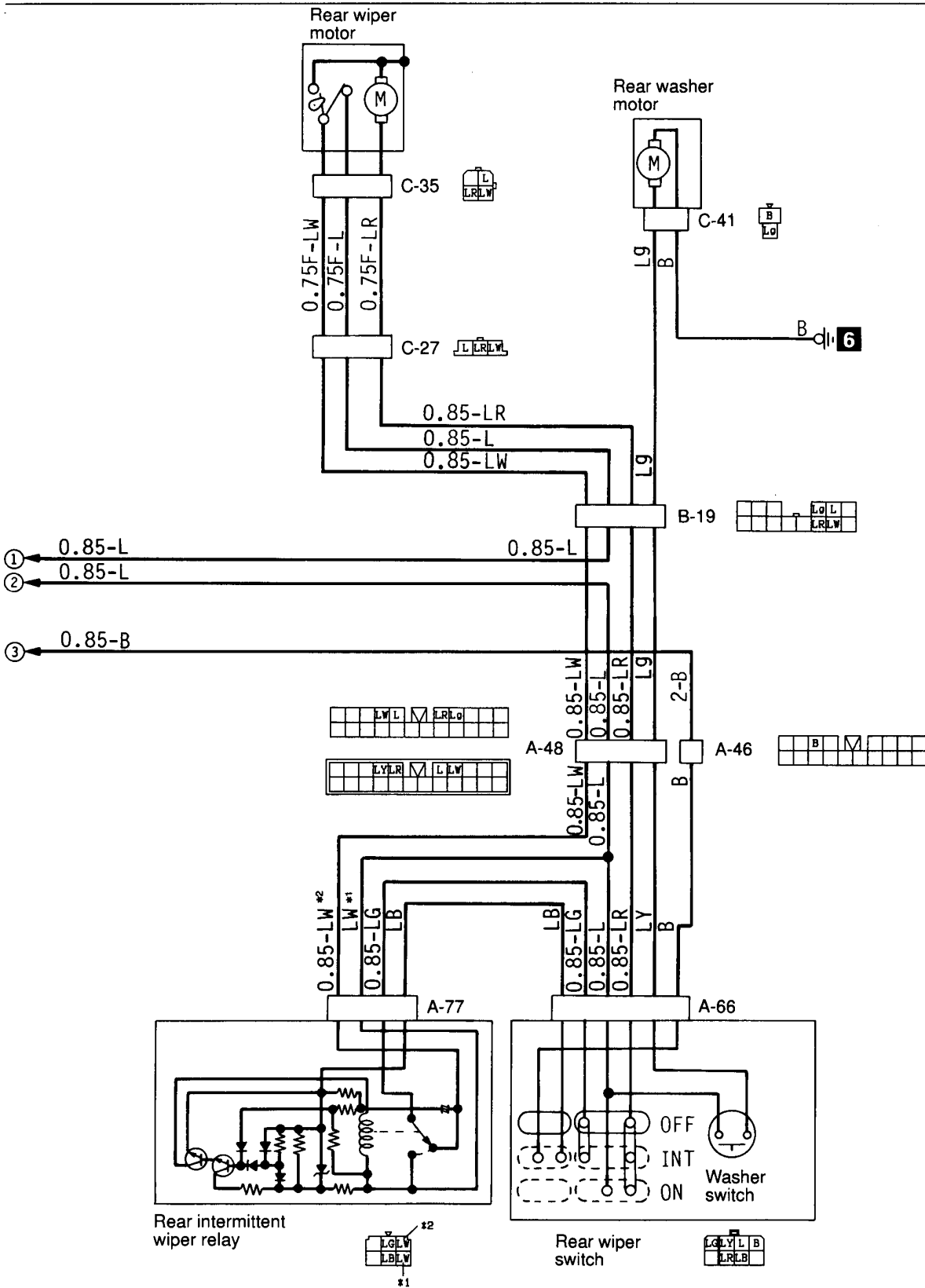

Wire colour code

B: Black Br: Brown G: Green Gr: Gray L: Blue Lg: Light green
 O: Orange P: Pink R: Red Sb: Sky blue V: Violet W: White Y: Yellow

37G0552

HEADLAMP WASHER

L.H. drive vehicles with SRS

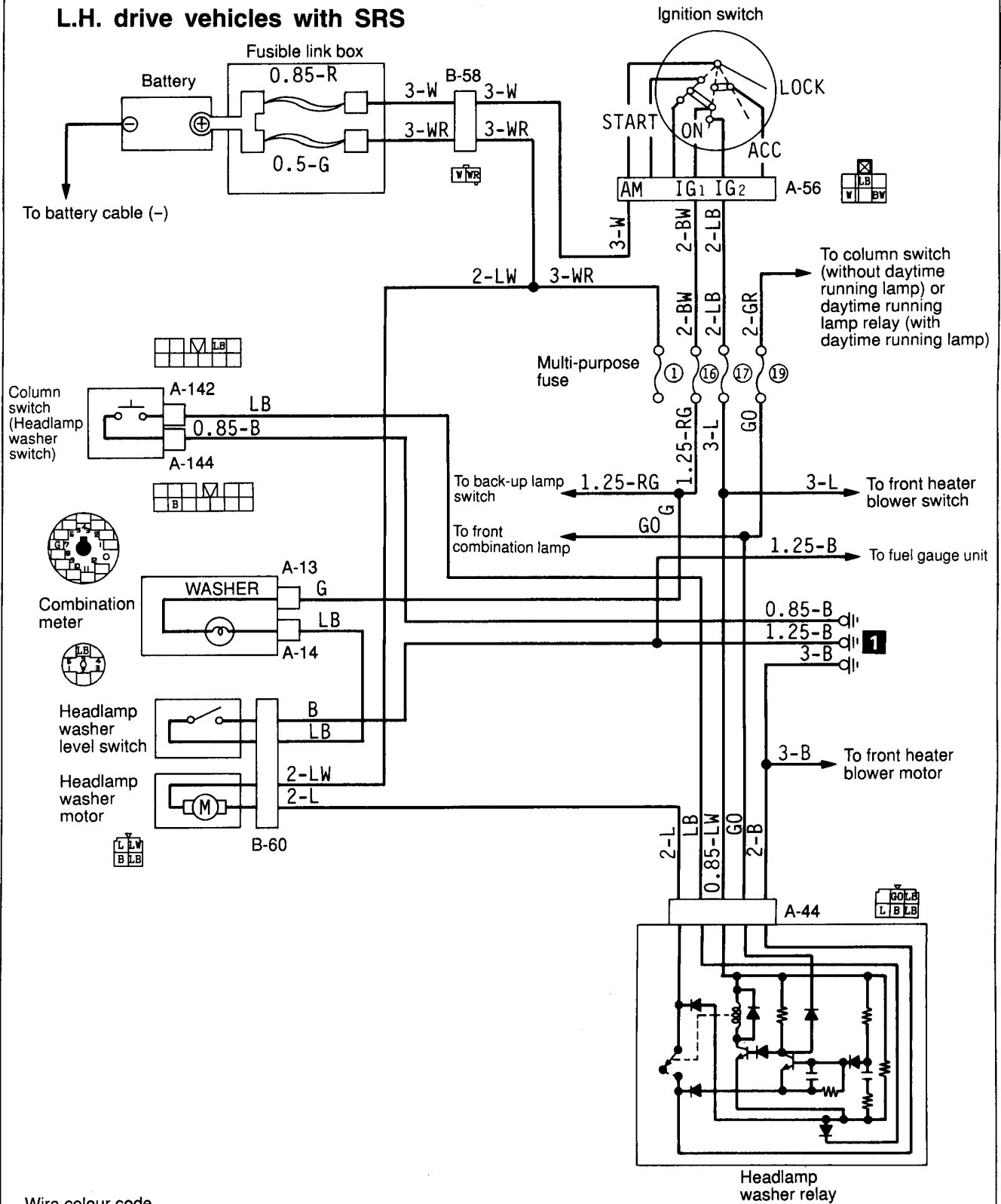

Wire colour code

B: Black Br: Brown G: Green Gr: Gray L: Blue Lg: Light green
 O: Orange P: Pink R: Red Sb: Sky blue V: Violet W: White Y: Yellow

NOTES

SUPPLEMENTAL RESTRAINT SYSTEM (SRS)

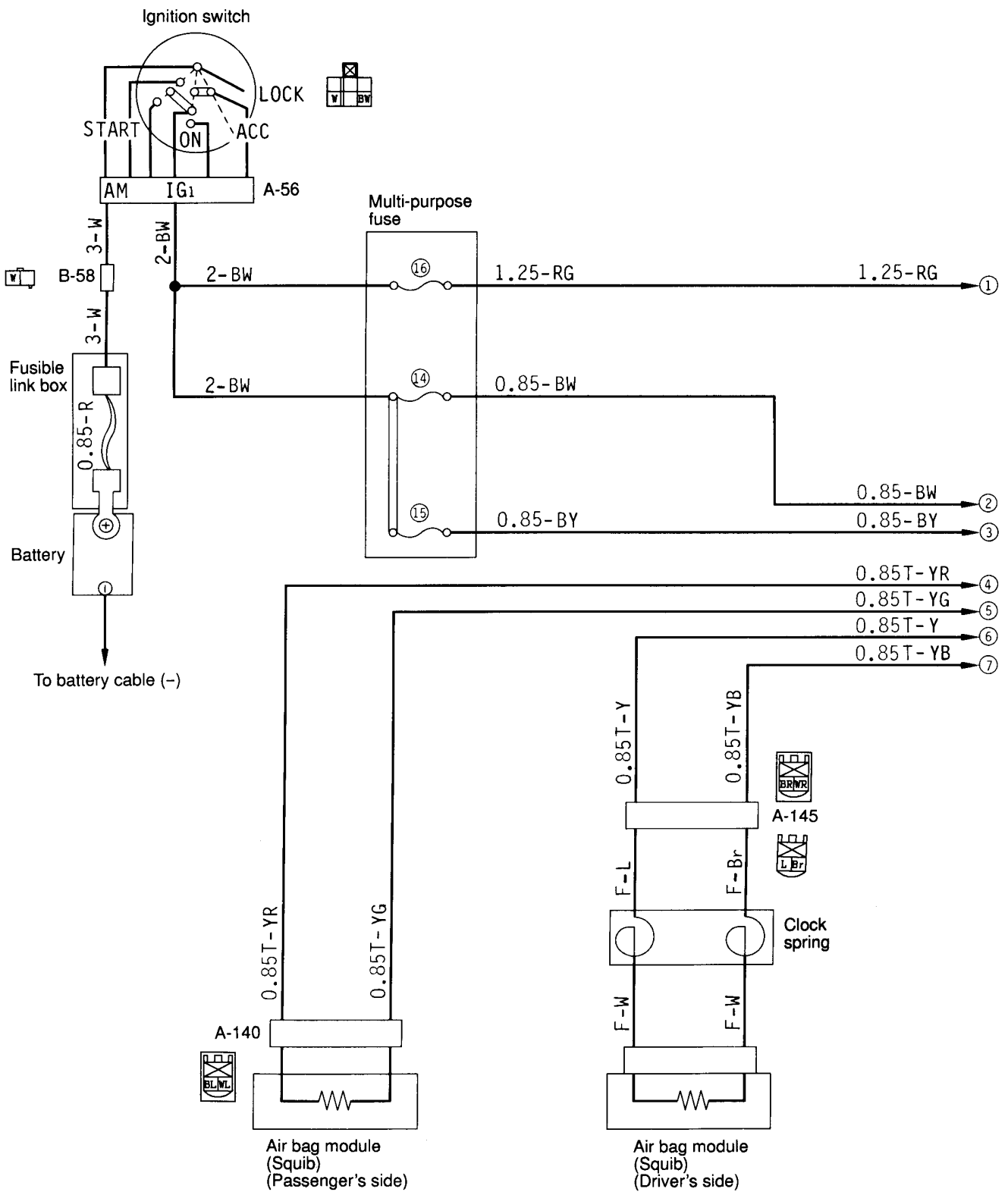

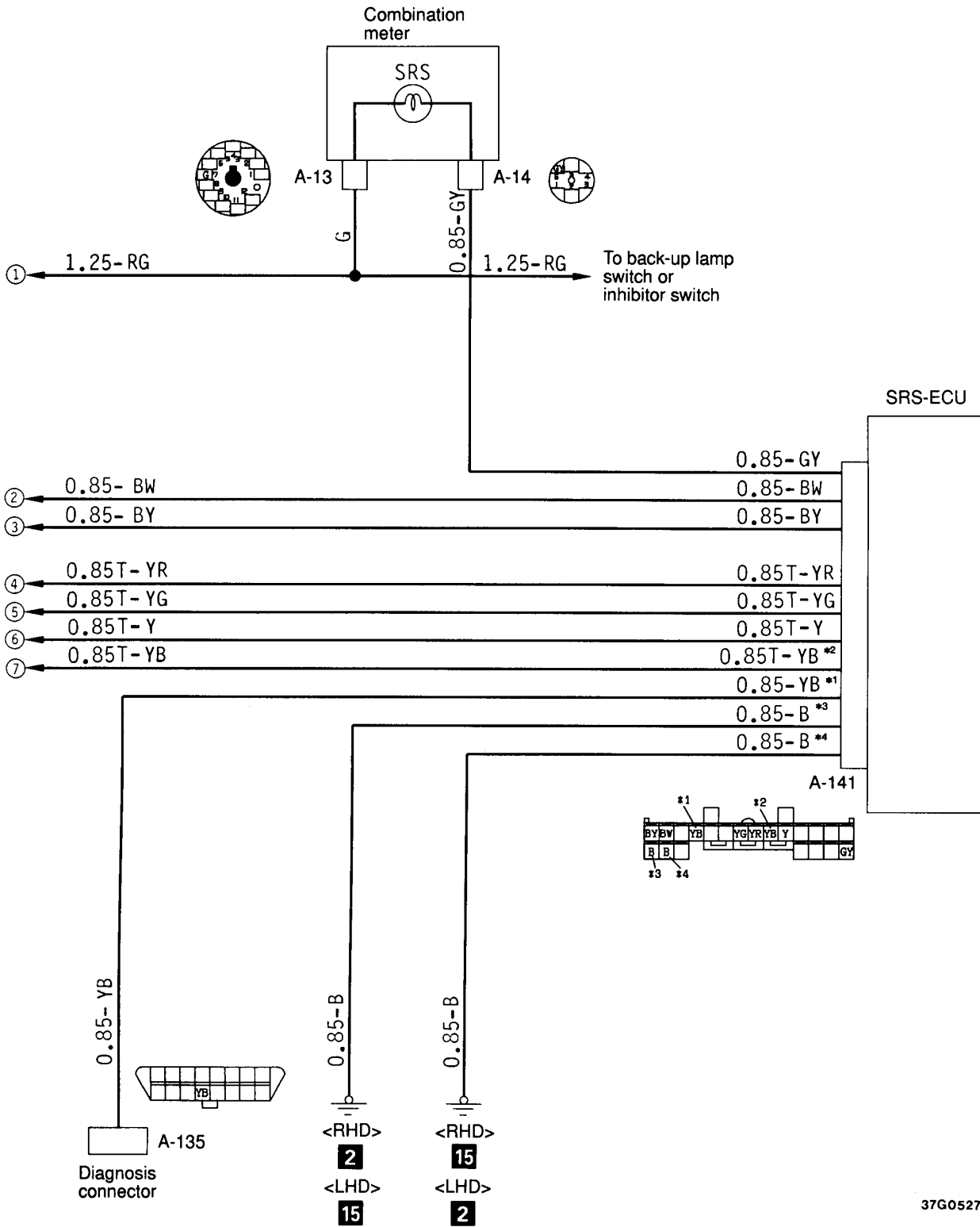

CENTRALIZED JUNCTION

MULTI-PURPOSE FUSE

Power supply circuit		Fuse No.	Rated capacity (A)	Load circuit
Ignition switch	IG1	14	10	SRS-ECU
		15	10	SRS-ECU

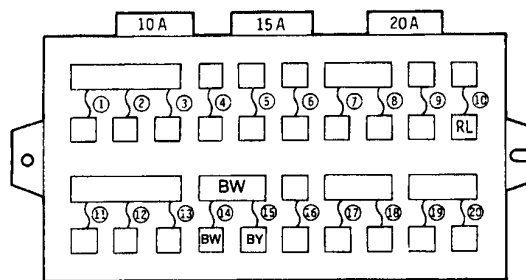

37G0123