



Workshop Manual

electrical wiring

SUPPLEMENT

L300 '97

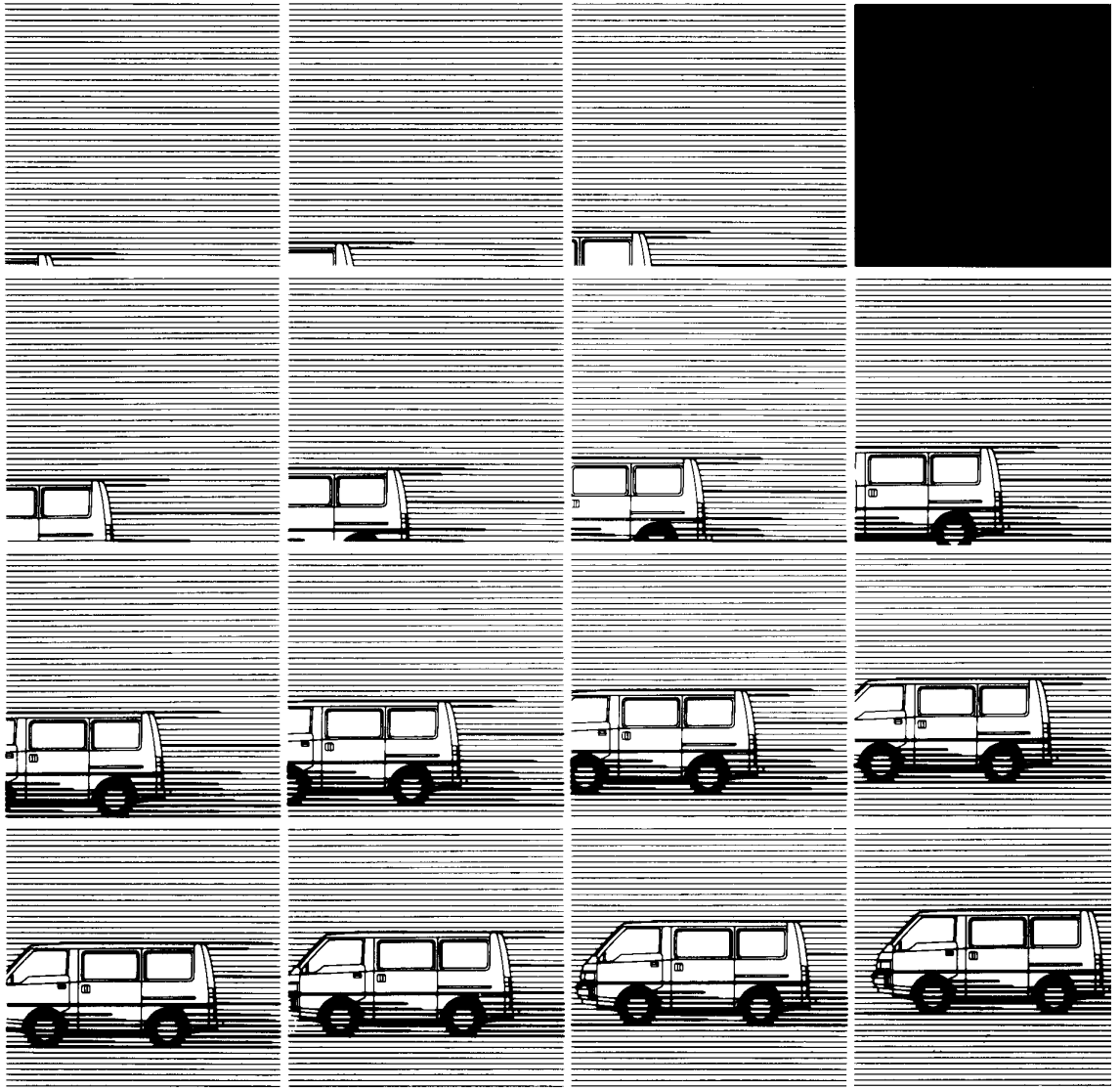

Pub. No. PHWE8907-5
(PHWE9022-4)

MITSUBISHI L300

ELECTRICAL WIRING SUPPLEMENT

FOREWORD

This publication is a supplement to the Electrical Wiring Manual Pub. Nos. PHWE8907, PHWE8907-1, PHWE8907-2, PHWE8907-3, PHWE8907-4, PHWE9022, PHWE9022-1, PHWE9022-2, PHWE9022-3 and contains only additions and changes to the original issue.

It is recommended that all service mechanics engaged in the servicing of the vehicle refer to the following publications as well as this manual.

WORKSHOP MANUAL

ENGINE GROUP

PWEE□□□□

(Looseleaf edition)

CHASSIS GROUP

PWWE8608

(Looseleaf edition)

PWWE9409□

PARTS CATALOGUE

B603180□A□

B803180□A□

BFA3180□A□

All information, illustrations and product descriptions contained in this manual are current as of time of publication. We, however, reserve the right to make changes at any time without prior notice or obligation.

GROUP INDEX

OUTLINE OF CHANGES

HOW TO READ THE
WIRING DIAGRAMS

WIRING HARNESS
CONFIGURATION DIAGRAMS

SINGLE PART
INSTALLATION POSITION

CIRCUIT DIAGRAM

1

2

3

4



HOW TO USE THIS MANUAL

CONTENTS

The preceding page contains GROUP INDEX which lists the group title and group number.

PAGE NUMBERS

All page numbers consist of two sets of digits separated by a dash. The digits preceding the dash identify the number of the group. The digits following the dash represent the consecutive page number within the group. The page numbers can be found on the top left or right of each page.

OPERATION AND TROUBLESHOOTING HINTS

In the GROUP 4 circuit diagrams, the operation and troubleshooting hints are given on the previous page or following page for each circuit where necessary.

INDICATION OF DESTINATION

General Export, GCC and Australia used for convenience to indicate destination.

NOTE

1. "General Export" means territories other than Europe, GCC, Australia, New Zealand, the U.S.A. and Canada.
2. "GCC" indicates a classification within the models for General Export category: models for countries that are members of the (Persian) Gulf Cooperation Council of nations.
3. In some instances, vehicles with other specifications may be shipped to some countries.

OUTLINE OF CHANGES

CONTENTS

WIRING HARNESS CONFIGURATION DIAGRAMS	2
SINGLE PART INSTALLATION POSITION	2
CIRCUIT DIAGRAM	2
CONNECTOR	3



WIRING HARNESS CONFIGURATION DIAGRAMS

Wiring harness configuration diagram			Reference page	Description of changes
Connector symbol	Name			
A	INSTRUMENT PANEL	L.H. drive vehicles for Europe	2-2	<ul style="list-style-type: none"> The number of pins in the engine control relay connector <MPI> (A-26) has been changed. The fuel pump relay connector <MPI> (A-136) has been added.
		R.H. drive vehicles for Europe	2-2	<ul style="list-style-type: none"> The number of pins in the engine control relay connector <MPI> (A-26) has been changed. The fuel pump relay connector <MPI> (A-136) has been added.
		L.H. drive vehicles for General Export	2-3	<ul style="list-style-type: none"> The number of pins in the engine control relay connector <MPI> (A-99) has been changed. The fuel pump relay connector <MPI> (A-117) has been added.
		Vehicles for Australia	2-3	<ul style="list-style-type: none"> The number of pins in the engine control relay connector <MPI> (A-99) has been changed. The fuel pump relay connector <MPI> (A-117) has been added.
B	ENGINE ROOM AND UNDER FLOOR	Petrol-powered vehicles for Europe <L.H. drive 2WD vehicles with 4G63-MPI>	2-4	<ul style="list-style-type: none"> The number of pins in the front wiring harness and fuel gauge wiring harness combination connector (B-63) has been changed. The front wiring harness and fuel gauge wiring harness combination connector (B-135) has been added.
		Petrol-powered vehicles for Europe <R.H. drive 2WD vehicles with 4G63-MPI>	2-5	<ul style="list-style-type: none"> The number of pins in the front wiring harness and fuel gauge wiring harness combination connector (B-63) has been changed. The front wiring harness and fuel gauge wiring harness combination connector (B-135) has been added.
		Petrol-powered vehicles for General Export <L.H. drive 2WD vehicles with 4G63-MPI>	2-6	<ul style="list-style-type: none"> The number of pins in the front wiring harness and fuel gauge wiring harness combination connector (B-49) has been changed. The number of pins in the front wiring harness and fuel gauge wiring harness combination connector (B-50) has been changed.
		Petrol-powered vehicles for Australia <Vehicles with 4G64-MPI>	2-7	<ul style="list-style-type: none"> The number of pins in the front wiring harness and fuel gauge wiring harness combination connector (B-49) has been changed. The front wiring harness and fuel gauge wiring harness combination connector (B-50) has been added.

SINGLE PART INSTALLATION POSITION

Location of change	Reference page	Description of change
RELAY MOUNTING LOCATION	3-2	The MPI control relay connector (8-pin) has been separated into an engine control relay connector (4-pin) and a fuel pump relay connector (4-pin).

CIRCUIT DIAGRAM

Circuit diagrams			Reference page	Description of change
Title	Classification			
MPI CIRCUIT	-	4-2, 4, 6	The MPI control relay has been separated into an engine control relay and a fuel pump relay.	
METER AND GAUGE CIRCUIT	Petrol-powered vehicles for Australia	4-8	The brake warning lamp circuit and the parking brake warning lamp circuit have been combined.	

CONNECTOR

- The front wiring harness to fuel wiring harness connectors in MPI vehicles have been changed to waterproof-type connectors. Furthermore, because there have been no changes to the circuits, a comparison of the terminal layouts for the old and new connectors are shown in the table below.

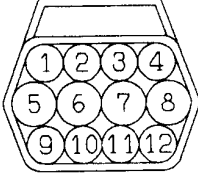
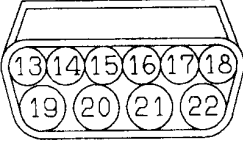
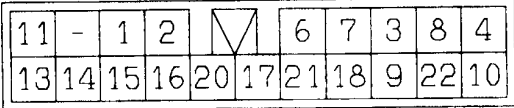
New connector			Old connector					
B-63*1 B-49*2 			B-135*1 B-50*2 			B-63*1 B-49*2 		
Terminal No.	Fuel gauge wiring harness side		Front wiring harness side		Circuit diagram			
	Wire size (mm ²)	Wire colour code	Wire size (mm ²)	Wire colour code				
1	0.5	YR	0.3	YR	Overdrive circuit*3			
2	0.3	YL	0.5	YL	Meter and gauge circuit			
3	0.5	YG	0.3	YG	Overdrive circuit*3			
4	-	-	-	-	-			
5	-	-	-	-	-			
6	0.85	RL	0.85	RL	Overdrive circuit*3, Back-up lamp circuit			
7	2	RG	1.25	Y	MPI circuit			
8	2	BW	0.5	B	Starting circuit*3, Overdrive circuit*3			
9	0.5	BY	0.3	BY	Overdrive circuit*3			
10	-	-	-	-	-			
11	-	-	-	-	-			
12	-	-	-	-	-			
13	-	-	-	-	-			
14	0.5	Y	0.3	Y	Overdrive circuit*3			
15	0.5	BW	0.3	BW	Overdrive circuit*3			
16	0.3	YB	0.5	YB	Meter and gauge circuit			
17	0.5	YW	0.5	YW	Meter and gauge circuit			
18	0.5	BL	0.5	BW	Overdrive circuit*3			
19	-	-	-	-	-			
20	0.5 1.25	B B	0.85	B	Starting circuit*3, MPI circuit, Meter and gauge circuit			
21	0.85	RG	1.25	RG	Overdrive circuit*3, Back-up lamp circuit, Meter and gauge circuit			
22	2	BY	2	BY	Overdrive circuit*3			

NOTE

- (1) *1: Vehicles for Europe
- (2) *2: Vehicles for General Export and Australia
- (3) *3: Vehicles for Australia

HOW TO READ THE WIRING DIAGRAMS

CONTENTS

MODELS 1-2



MODELS**VEHICLES FOR EUROPE**

Model code	Engine model	Transmission model	Body type
P05VLZAL6	4D56	R5M21	Window van
P05VGLZL6	4D56	R5M21	Panel van
P05VGLZR6	4D56	R5M21	Panel van
P15VJLZL6	4D56	R5M21	Panel van (Long body)
P15VJLZR6	4D56	R5M21	Panel van (Long body)
P15VHLZL6	4D56	R5M21	Window van (Long body)
P45VJLNTL6	4D56	V5M21	Panel van <4WD> (Long body)
P03VLZEL6	4G63	R5M21	Window van
P03VGLZEL6	4G63	R5M21	Panel van
P03VGLZER6	4G63	R5M21	Panel van
P13VJLZEL6	4G63	R5M21	Panel van (Long body)
P13VJLZER6	4G63	R5M21	Panel van (Long body)
P13VHLZEL6	4G63	R5M21	Window van (Long body)
P25VGLNTL6	4D56	V5M21	Panel van <4WD>
P03WLZXEL6*	4G63	R5M21	Mini-bus
P05WLZXL6	4D56	R5M21	Mini-bus

NOTE

* Indicates a new model

VEHICLES FOR GENERAL EXPORT

Model code	Engine model	Transmission model	Body type
P06VGLNL*	4G92	R5M21	Panel van
P06VGLNR*	4G92	R5M21	Panel van
P16VJLNL*	4G92	R5M21	Panel van (Long body)
P16VJLNR*	4G92	R5M21	Panel van (Long body)
P13VJLNEL*	4G63	R5M21	Panel van (Long body)
P15VJLNL*	4D56	R5M21	Panel van (Long body)
P15VJLNR*	4D56	R5M21	Panel van (Long body)
P06VGLNAR1D*	4G92	R5M21	Panel van
P16VJLNAR1D*	4G92	R5M21	Panel van (Long body)
P03WSNUL*	4G63	R5M21	Mini-bus
P13WHLNL*	4G63	R5M21	Mini-bus (Long body)
P13WHLNR*	4G63	R5M21	Mini-bus (Long body)
P15WHLNL*	4D56	R5M21	Mini-bus (Long body)
P15WHLNR*	4D56	R5M21	Mini-bus (Long body)
P23WSNUL	4G63	R5M21	Mini-bus

NOTE

* Indicates new models

VEHICLES FOR GCC

Model code	Engine model	Transmission model	Body type
P03VGLNLW*	4G63	R5M21	Panel van
P13VJLNLW*	4G63	R5M21	Panel van (Long body)
P15VJLNLW*	4D56	R5M21	Panel van (Long body)
P03WSNULW*	4G63	R5M21	Mini-bus
P03WSRULW	4G63	R4AW2	Mini-bus
P13WHLNLW*	4G63	R5M21	Mini-bus (Long body)
P15WHLNLW*	4D56	R5M21	Mini-bus (Long body)

NOTE

* Indicates new models

VEHICLES FOR AUSTRALIA

Model code	Engine model	Transmission model	Body type
P03VGSNR8	4G63	R5M21	Panel van
P03VGSRR8	4G63	R4AW2	Panel van
P03VSNR8	4G63	R5M21	Window van
P03VSRR8	4G63	R4AW2	Window van
P14VJLNER8	4G64	R5M21	Panel van (Long body)
P14VJLRER8	4G64	R4AW2	Panel van (Long body)
P24VGSNER8	4G64	V5M21	Panel van <4WD>
P05VGSNR8	4D56	R5M21	Panel van
P15VJLNR8	4D56	R5M21	Panel van (Long body)
P03WSNR8	4G63	R5M21	Mini-bus
P03WSRR8	4G63	R4AW2	Mini-bus

WIRING HARNESS CONFIGURATION DIAGRAMS

CONTENTS

INSTRUMENT PANEL **A**

L.H. drive vehicles for Europe	2-2
R.H. drive vehicles for Europe	2-2
L.H. drive vehicles for General Export	2-3
Vehicles for Australia	2-3

ENGINE ROOM AND UNDER FLOOR **B**

Petrol-powered vehicles for Europe <L.H. drive 2WD vehicles with 4G63-MPI>	2-4
Petrol-powered vehicles for Europe <R.H. drive 2WD vehicles with 4G63-MPI>	2-5
Petrol-powered vehicles for General Export <L.H. drive 2WD vehicles with 4G63-MPI>	2-6
Petrol-powered vehicles for Australia <Vehicles with 4G64-MPI>	2-7

INSTRUMENT PANEL

L.H. drive vehicles for Europe

- The engine control relay connector (A-26) has been changed in the MPI vehicle.
- The fuel pump relay connector (A-136) has been added to the MPI vehicle.

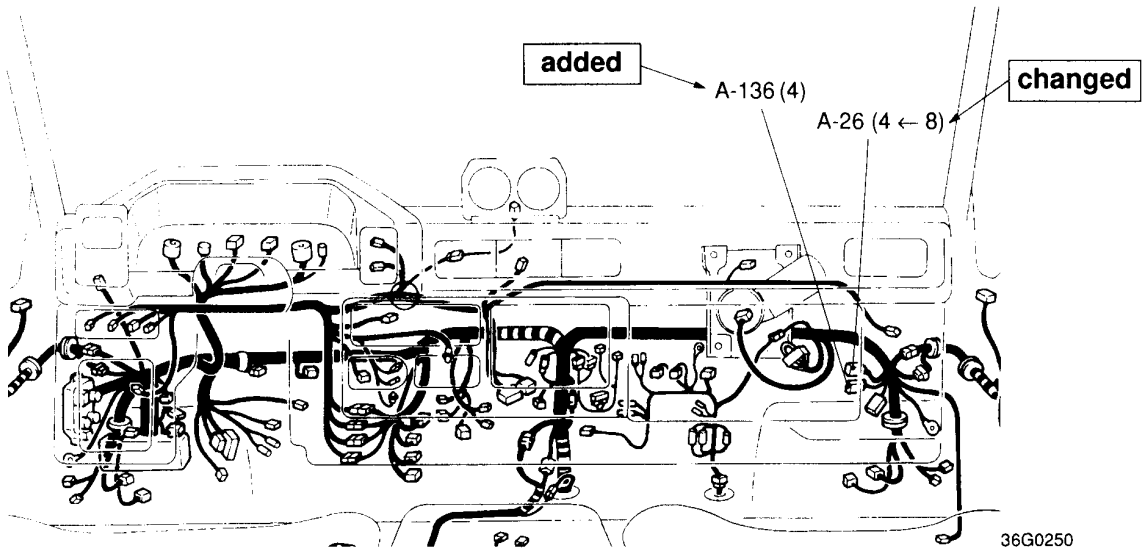

A-26 Engine control relay <MPI>
A-136 Fuel pump relay <MPI> ← **added**

R.H. drive vehicles for Europe

- The engine control relay connector (A-26) has been changed in the MPI vehicle.
- The fuel pump relay connector (A-136) has been added to the MPI vehicle.

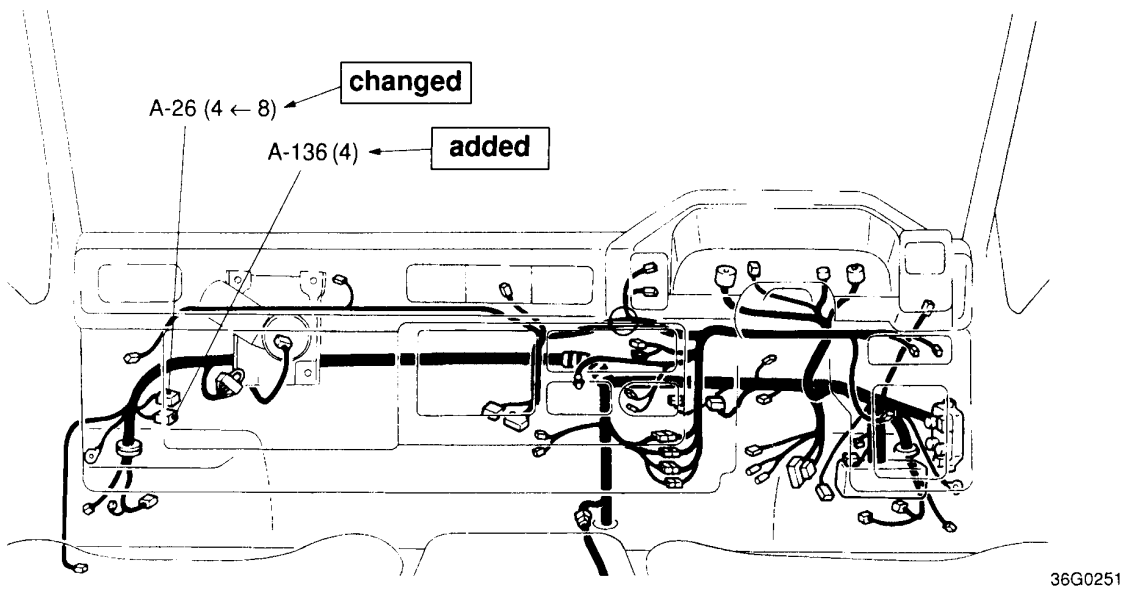

A-26 Engine control relay <MPI>
A-136 Fuel pump relay <MPI> ← **added**

L.H. drive vehicles for General Export

- The engine control relay connector (A-99) has been changed in the MPI vehicle.
- The fuel pump relay connector (A-117) has been added to the MPI vehicle.

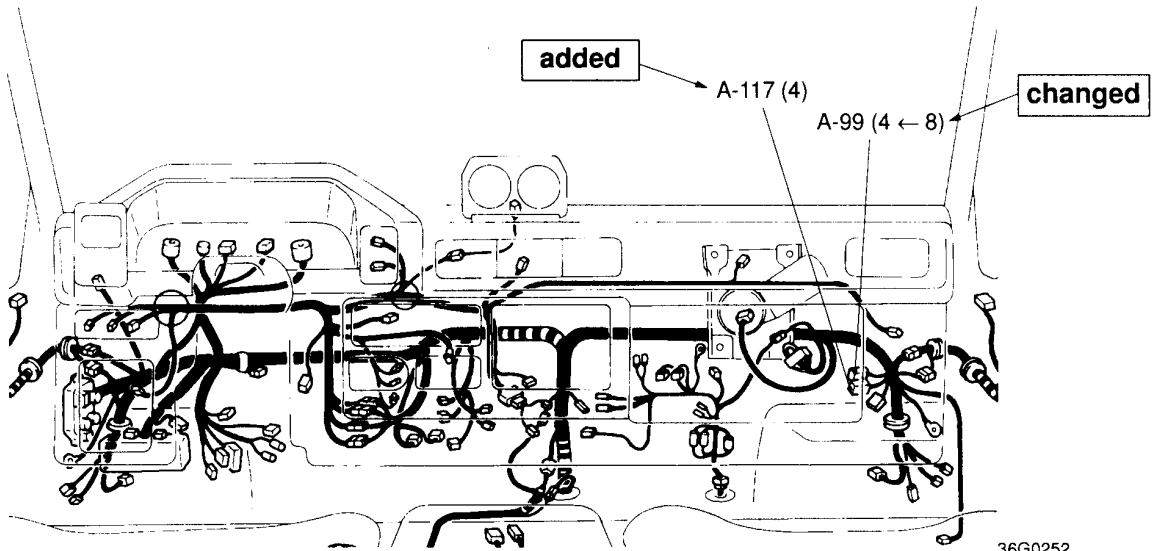

36G0252

A-99 Engine control relay <MPI>
 A-117 Fuel pump relay <MPI> ← **added**

Vehicles for Australia

- The engine control relay connector (A-99) has been changed in the MPI vehicle.
- The fuel pump relay connector (A-117) has been added to the MPI vehicle.

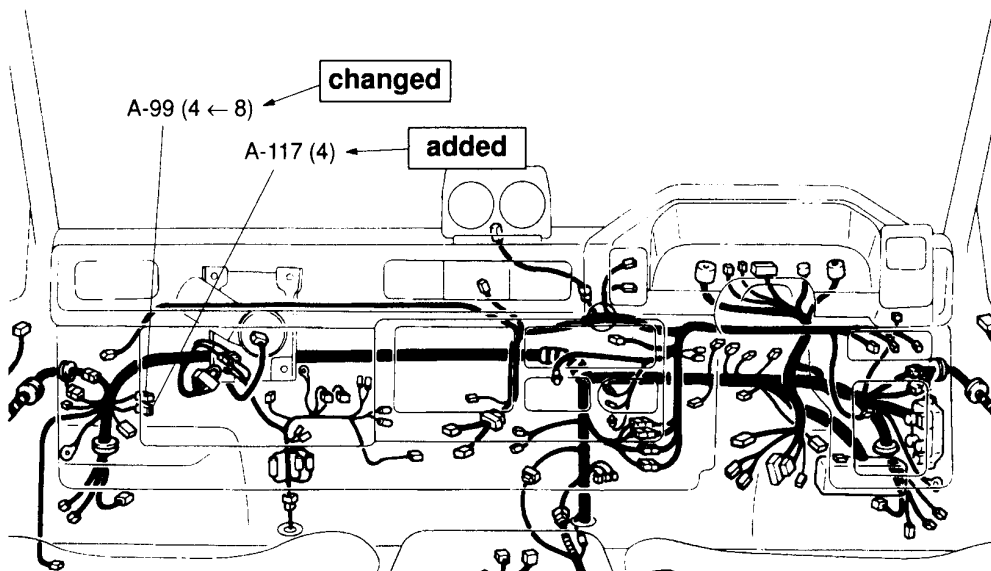

36G0253

A-99 Engine control relay <MPI>
 A-117 Fuel pump relay <MPI> ← **added**

ENGINE ROOM AND UNDER FLOOR

Petrol-powered vehicles for Europe <L.H. drive 2WD vehicles with 4G63-MPI>

- The front wiring harness and fuel gauge wiring harness combination connector (B-63) has been changed.
- The front wiring harness and fuel gauge wiring harness combination connector (B-135) has been changed.

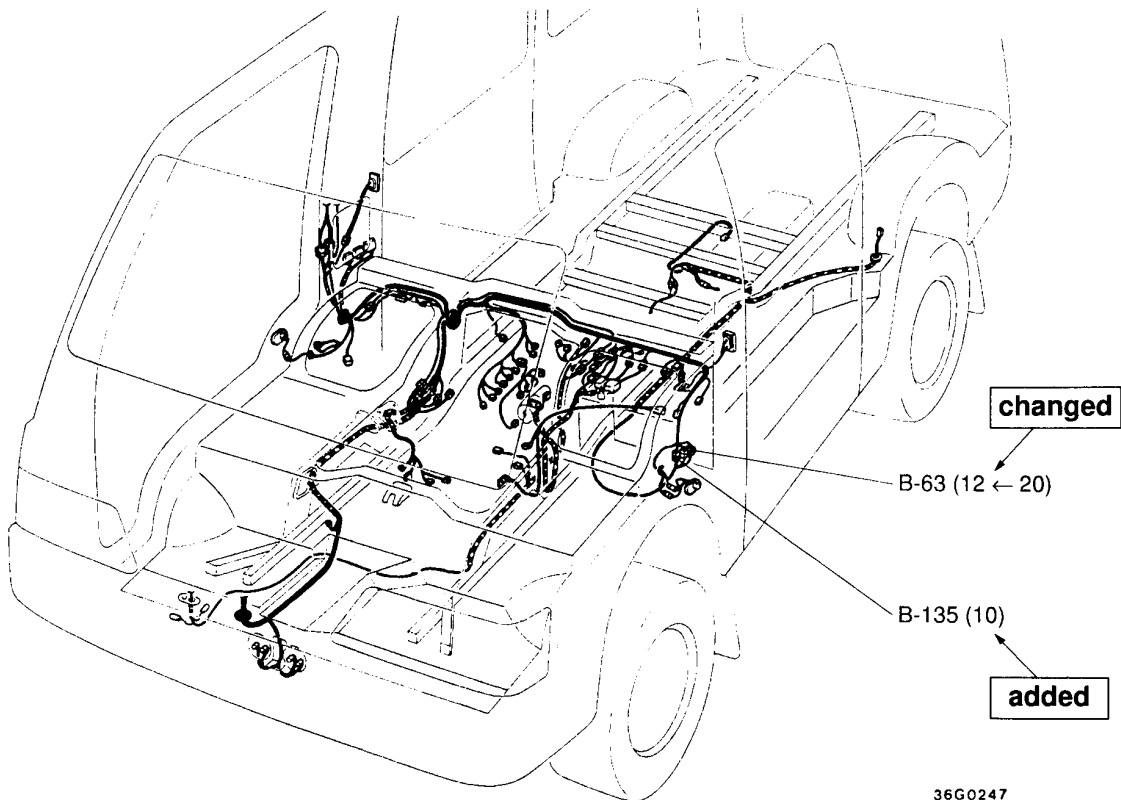

36G0247

B-63 Front wiring harness and fuel gauge wiring harness combination
 B-135 Front wiring harness and fuel gauge wiring harness combination

← added

**Petrol-powered vehicles for Europe
<R.H. drive 2WD vehicles with 4G63-MPI>**

- The front wiring harness and fuel gauge wiring harness combination connector (B-63) has been changed.
- The front wiring harness and fuel gauge wiring harness combination connector (B-135) has been added.

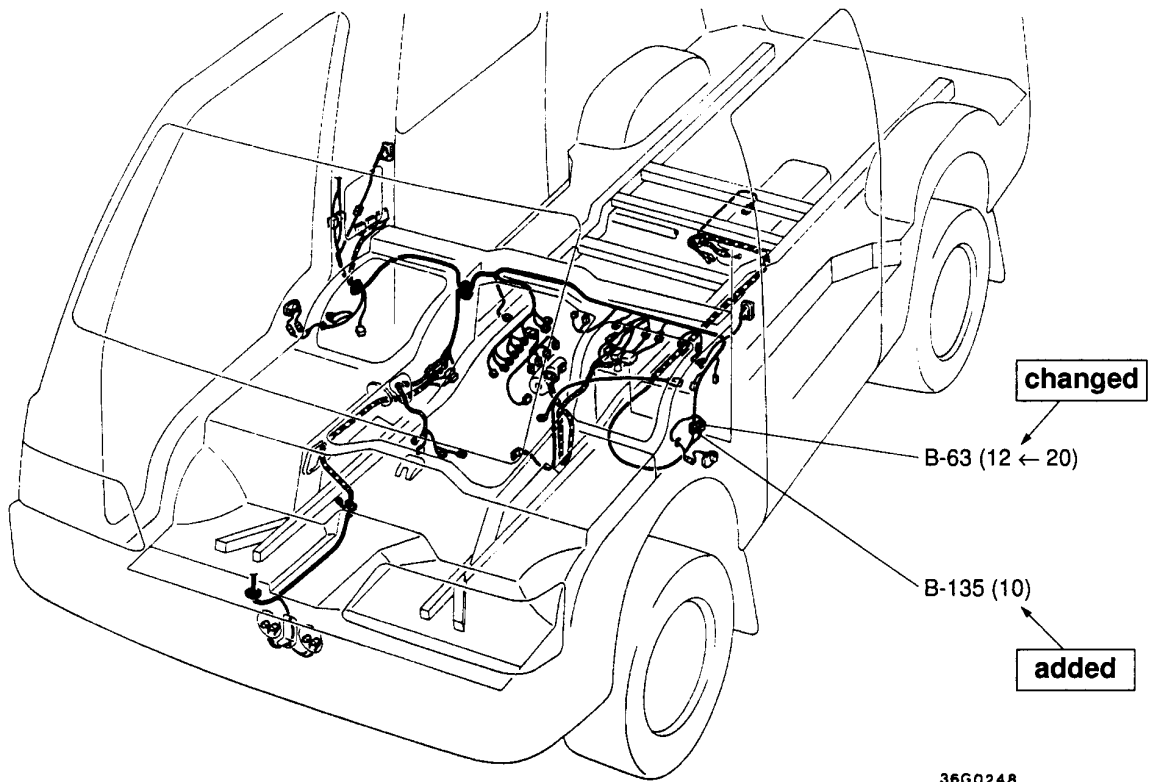

B-63 Front wiring harness and fuel gauge wiring harness combination
 B-135 Front wiring harness and fuel gauge wiring harness combination ← **added**

36G0248

**Petrol-powered vehicles for General Export
<L.H. drive 2WD vehicles with 4G63-MPI>**

- The front wiring harness and fuel gauge wiring harness combination connectors (B-49, B-50) have been changed.

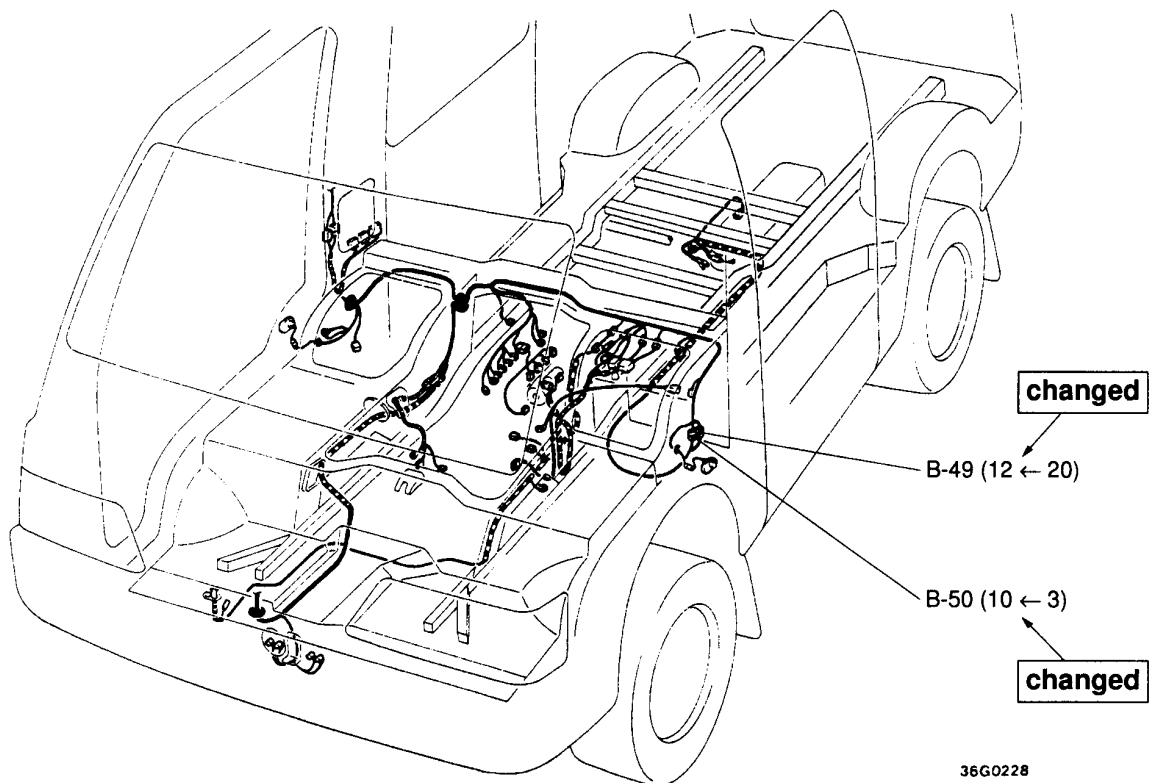

- B-49 Front wiring harness and fuel gauge wiring harness combination
B-50 Front wiring harness and fuel gauge wiring harness combination

Petrol-powered vehicles for Australia
<Vehicles with 4G63-MPI>

- The front wiring harness and fuel gauge wiring harness combination connector (B-49) has been changed.
- The front wiring harness and fuel gauge wiring harness combination connector (B-50) has been added.

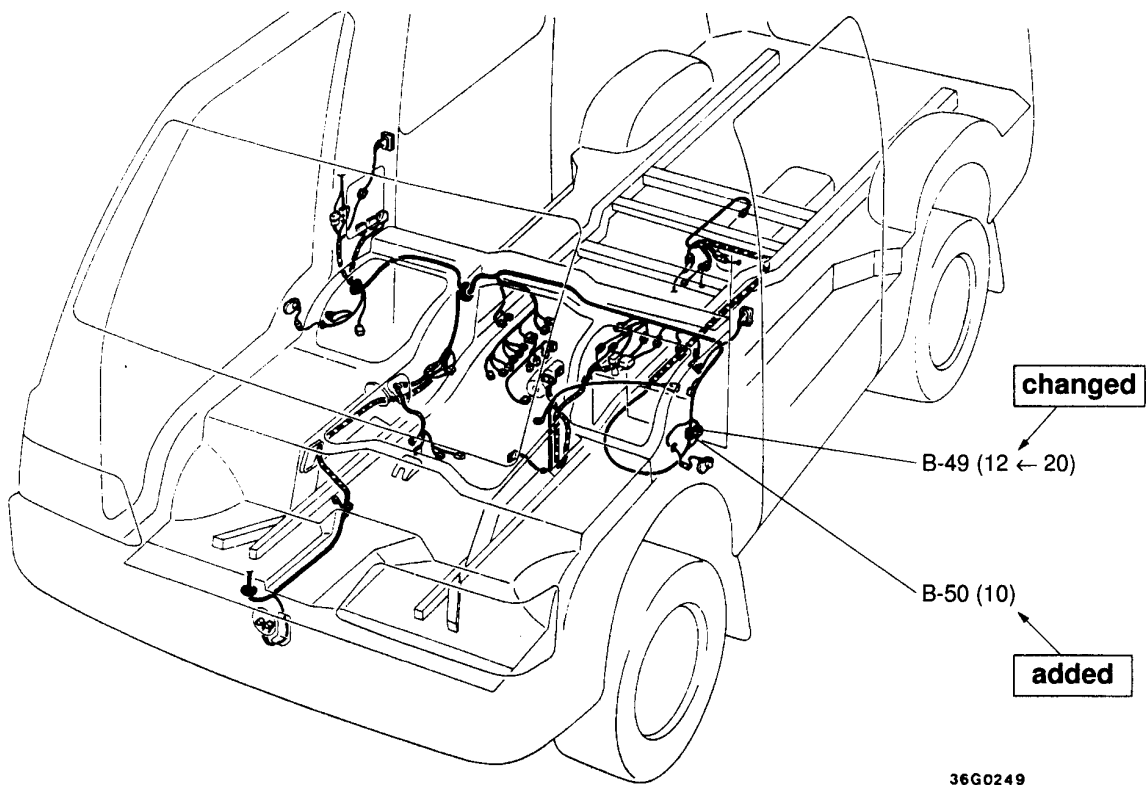

36G0249

- B-49 Front wiring harness and fuel gauge wiring harness combination
 B-50 Front wiring harness and fuel gauge wiring harness combination ← **added**

SINGLE PART INSTALLATION POSITION

CONTENTS

RELAY MOUNTING LOCATIONS 3-2



3-2 SINGLE PART INSTALLATION POSITION – Relay Mounting Locations

RELAY MOUNTING LOCATIONS

The fuel pump relay has been added to the MPI vehicle.
The engine control relay has been changed in the MPI vehicle.

Interior

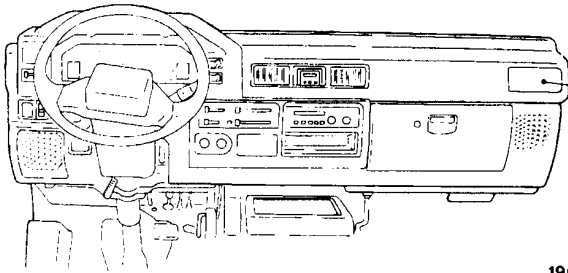

19G0361

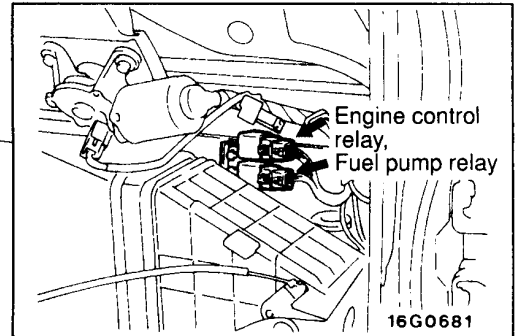

NOTE

Because the engine control relay and the fuel pump relay are essentially the same relay, the 4-pin connectors can be connected to either relay. The circuits used can be determined by the wire colours in the circuit diagram.

CIRCUIT DIAGRAM

CONTENTS

MPI CIRCUIT

Vehicles for Europe	4-2
Vehicles for General Export	4-4
Vehicles for Australia	4-6

METER AND GAUGE CIRCUIT

Petrol-powered vehicles for Australia	4-8
---	-----

MPI CIRCUIT

Vehicles for Europe

A circuit exclusive for the '97 model has been set.

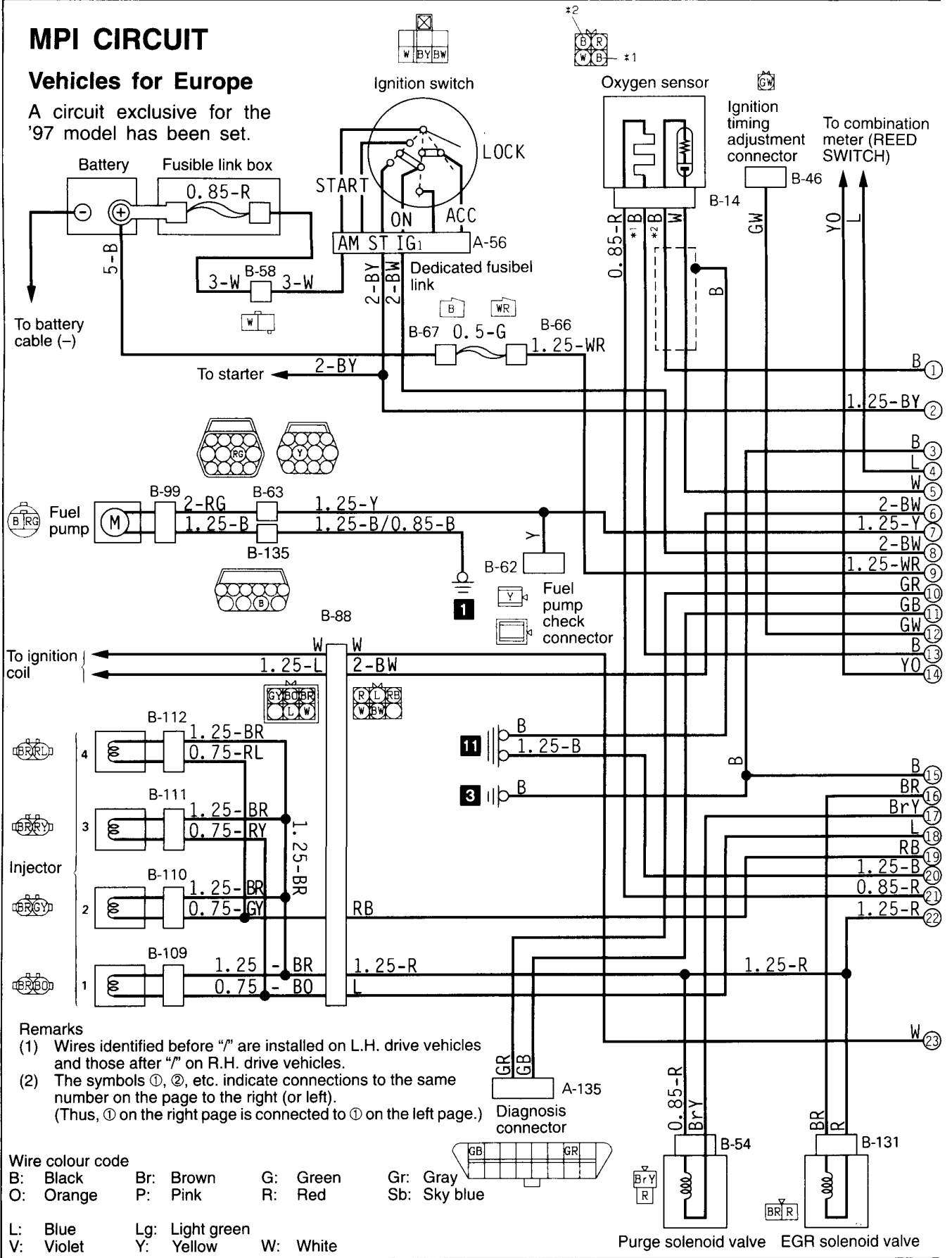

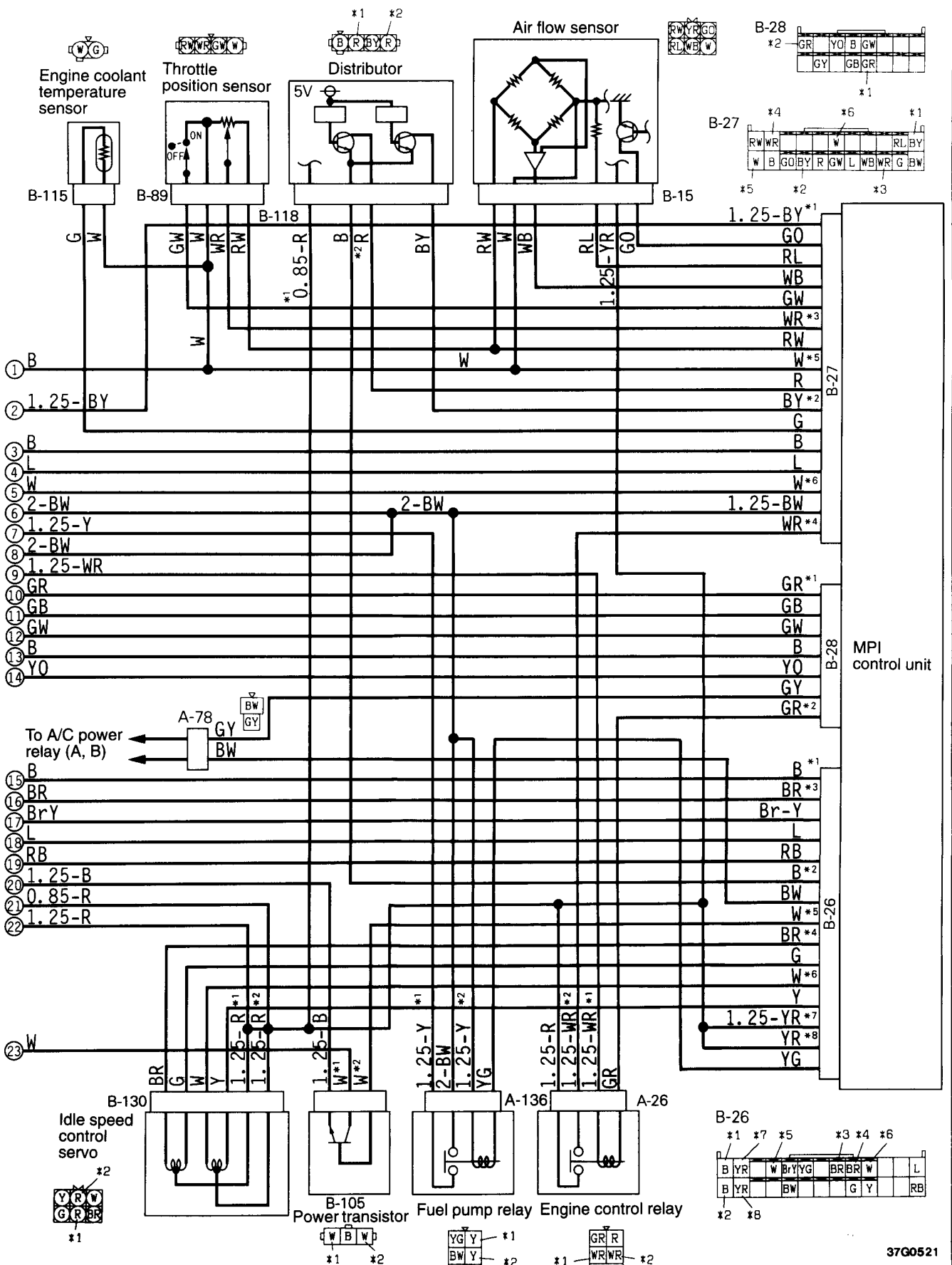

MPI CIRCUIT

Vehicles for General Export

A circuit exclusive for the '97 model has been set.

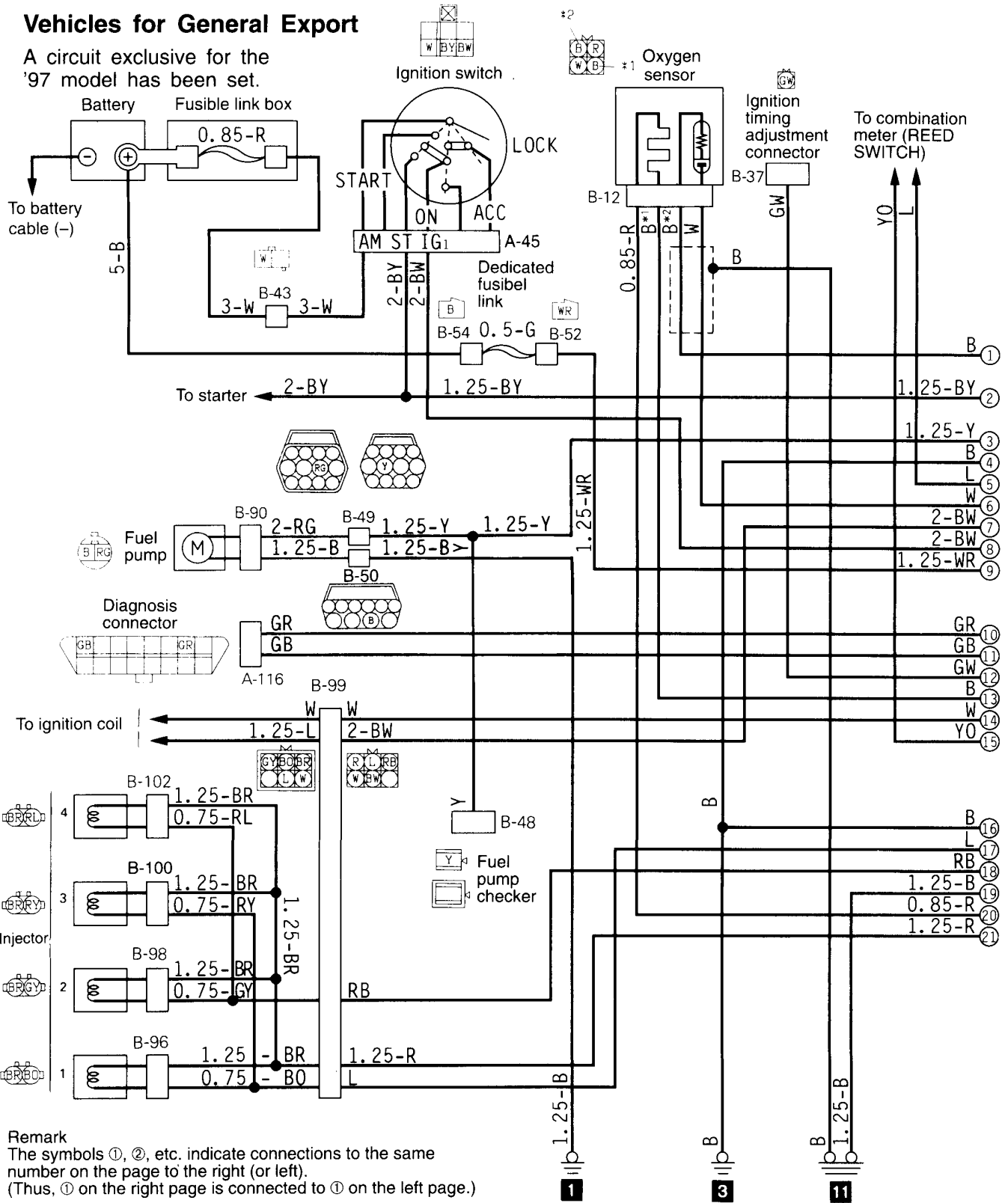

Remark
 The symbols ①, ②, etc. indicate connections to the same number on the page to the right (or left).
 (Thus, ① on the right page is connected to ① on the left page.)

W: White Y: Yellow

Wire colour code B: Black O: Orange Br: Brown P: Pink G: Green R: Red Gr: Gray Sb: Sky blue L: Blue V: Violet Lg: Light green

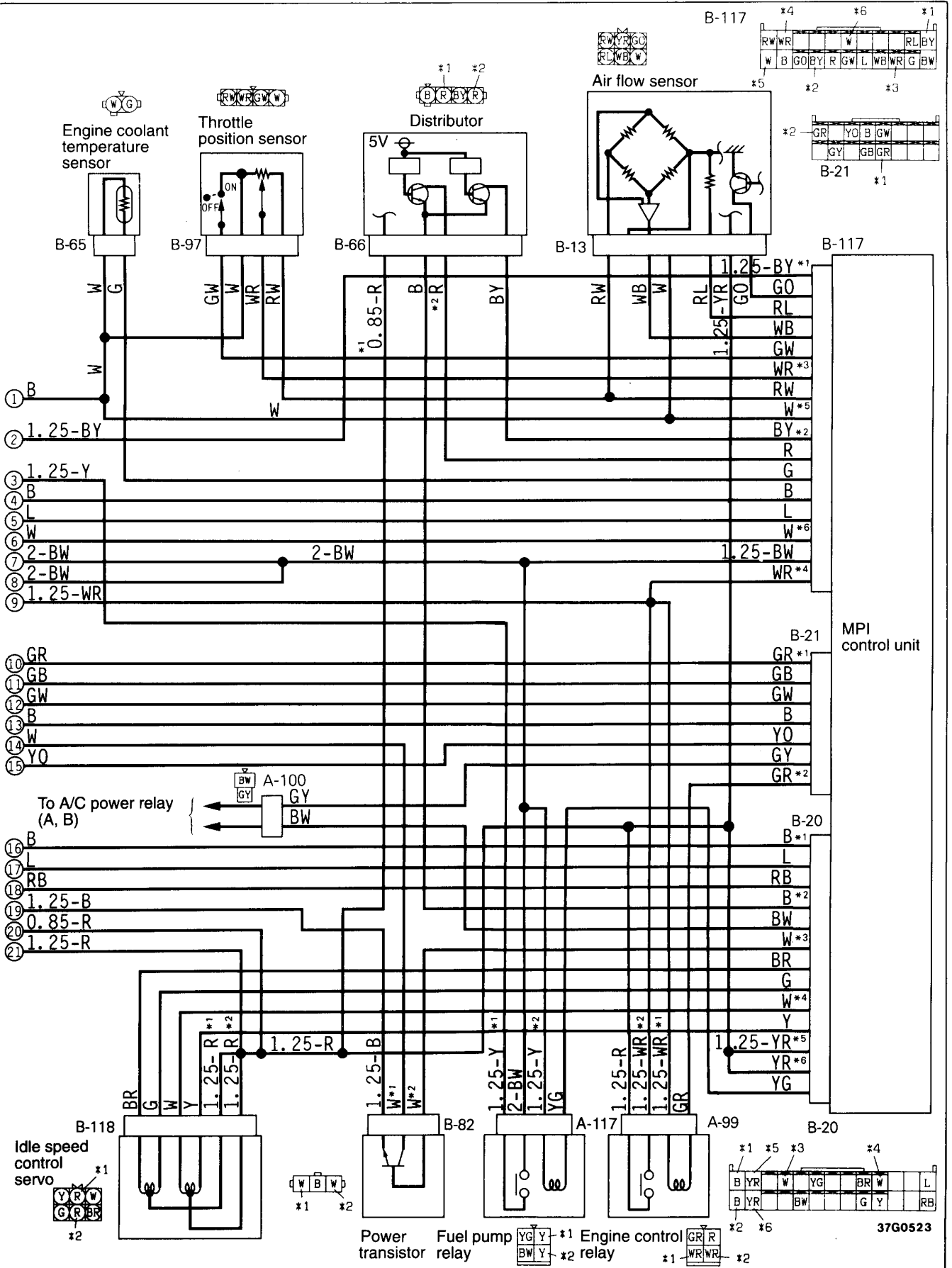

37G0523

MPI CIRCUIT

Vehicles for Australia

A circuit exclusive for the '97 model has been set.

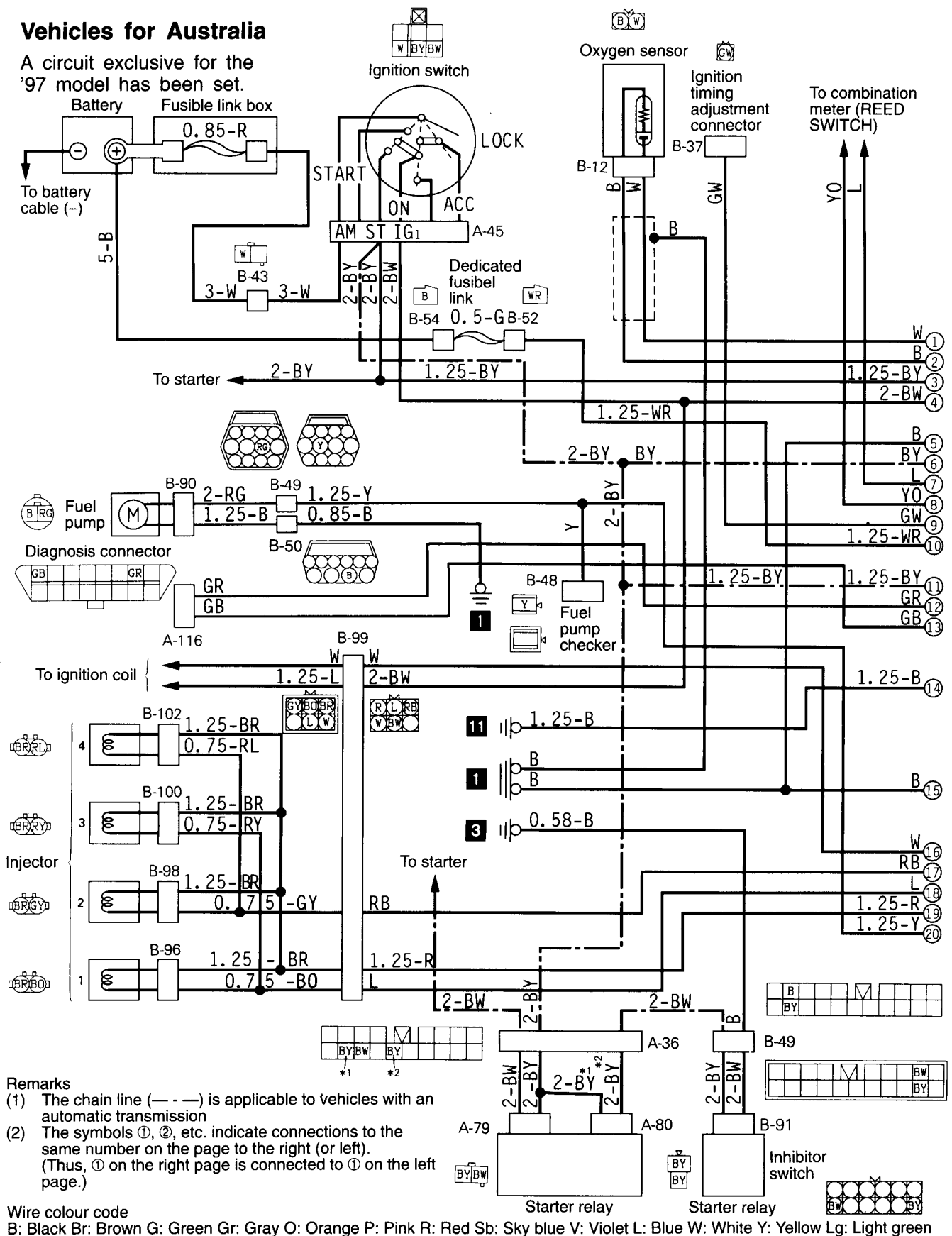

- Remarks**
- (1) The chain line (---) is applicable to vehicles with an automatic transmission
 - (2) The symbols ①, ②, etc. indicate connections to the same number on the page to the right (or left). (Thus, ① on the right page is connected to ① on the left page.)

Wire colour code
 B: Black Br: Brown G: Green Gr: Gray O: Orange P: Pink R: Red Sb: Sky blue V: Violet L: Blue W: White Y: Yellow Lg: Light green

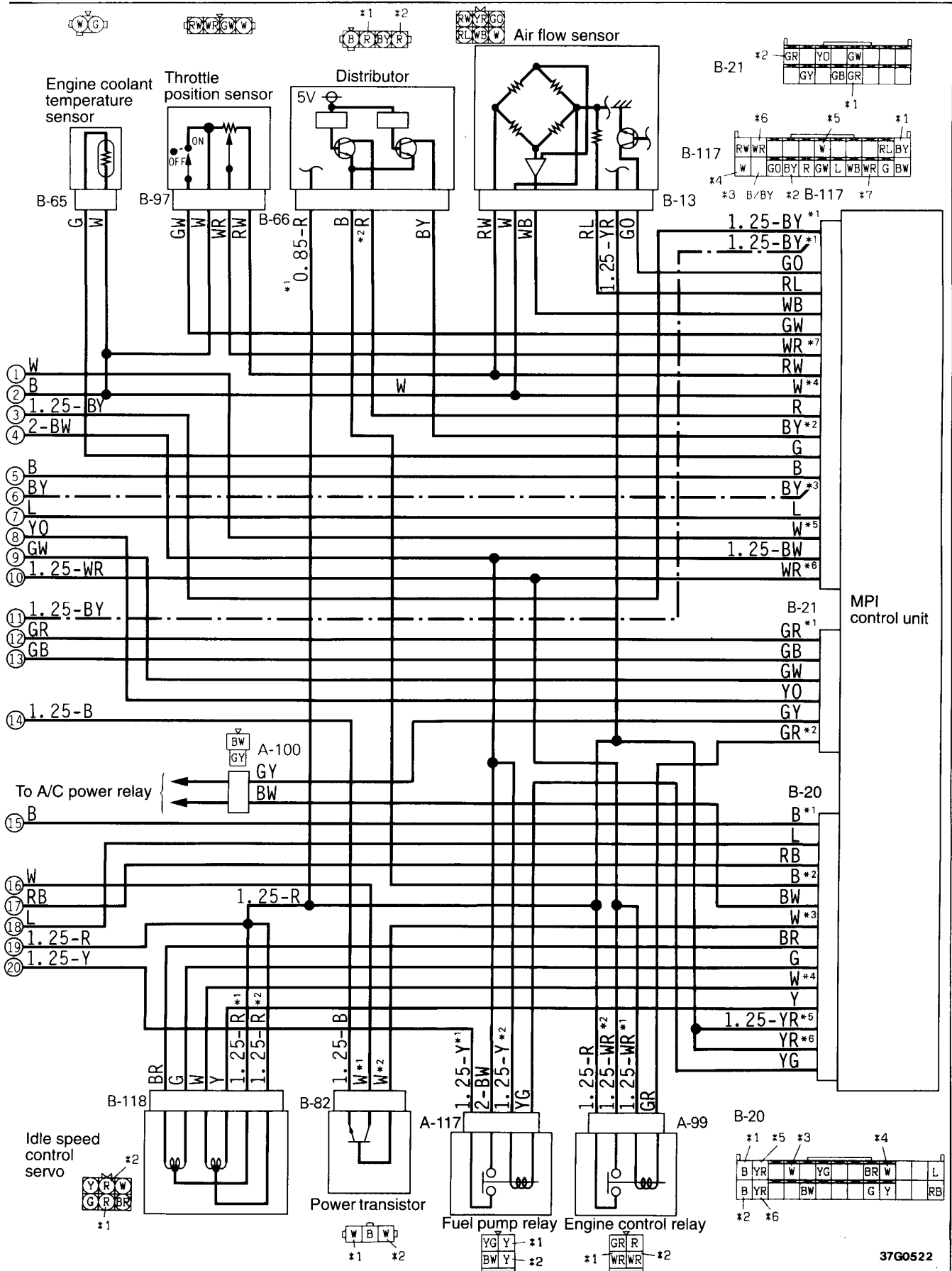

METER AND GAUGE

Petrol-powered vehicles for Australia

A circuit exclusive for the '97 model has been set.

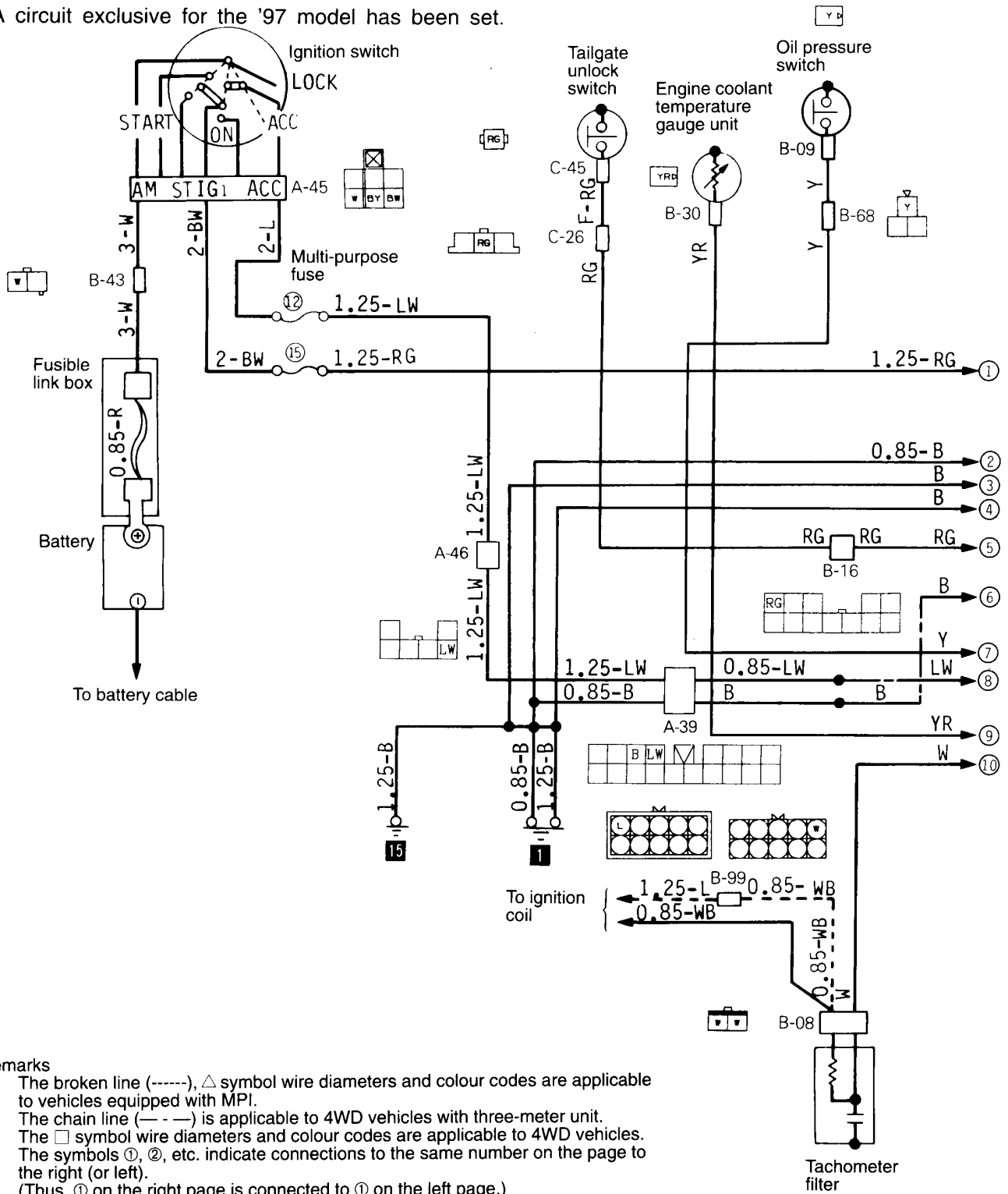

Remarks

- (1) The broken line (-----), Δ symbol wire diameters and colour codes are applicable to vehicles equipped with MPI.
- (2) The chain line (---) is applicable to 4WD vehicles with three-meter unit.
- (3) The □ symbol wire diameters and colour codes are applicable to 4WD vehicles.
- (4) The symbols ①, ②, etc. indicate connections to the same number on the page to the right (or left).
(Thus, ① on the right page is connected to ① on the left page.)

Wire colour code

B: Black	Br: Brown	G: Green	Gr: Gray	L: Blue	Lg: Light green
O: Orange	P: Pink	R: Red	Sb: Sky blue	V: Violet	W: White
					Y: Yellow

