



Workshop Manual

electrical wiring

SUPPLEMENT

L300 '92

MITSUBISHI L300

ELECTRICAL WIRING SUPPLEMENT

FOREWORD

This publication is a supplement to the Electrical Wiring Manual Pub. No. PHWE 8907 and contains only additions and changes to the original issue.

It is recommended that all service mechanics engaged in the servicing of the vehicle refer to the following publications as well as this manual.

WORKSHOP MANUAL

ENGINE GROUP PWEE□□□□
(Looseleaf edition)

CHASSIS GROUP PWWE 8608
(Looseleaf edition)

PARTS CATALOGUE B6031801AA

All information, illustrations and product descriptions contained in this manual are current as of time of publication. We, however, reserve the right to make changes at any time without prior notice or obligation.

GROUP INDEX

OUTLINE OF CHANGES

WIRING HARNESS
CONFIGURATION DIAGRAMS

SINGLE PART INSTALLATION
POSITION

CIRCUIT DIAGRAM



2

3

4



HOW TO USE THIS MANUAL

CONTENTS

The preceding page contains GROUP INDEX which lists the group title and group number.

PAGE NUMBERS

All page numbers consist of two sets of digits separated by a dash. The digits preceding the dash identify the number of the group. The digits following the dash represent the consecutive page number within the group. The page numbers can be found on the top left or right of each page.

OPERATION AND TROUBLESHOOTING HINTS

In the GROUP 4 circuit diagrams, the operation and troubleshooting hints are given on the previous page or following page for each circuit where necessary.

OUTLINE OF CHANGES

WIRING HARNESS CONFIGURATION DIAGRAMS	2
SINGLE PART INSTALLATION POSITION	3
CIRCUIT DIAGRAM	3
TABLE OF CIRCUIT DIAGRAMS	5

2 OUTLINE OF CHANGES — Wiring Harness Configuration Diagrams

WIRING HARNESS CONFIGURATION DIAGRAMS

Wiring harness configuration diagram					Description of changes
Connector symbol	No.	Name		Reference page	
A	2-1	INSTRUMENT PANEL	L.H. drive vehicles	2-2	<ul style="list-style-type: none"> A connector (A-126) that couples the front wiring harness and the instrument panel wiring harness has been added in line with the addition of the three meter unit. <4WD vehicles> Thermometer sensor connectors (A-124, A-125) have been added in line with the addition of the three meter unit. <4WD vehicles> A lighting monitor buzzer (A-127) has been added.
	2-2		R.H. drive vehicles	2-4	
B	3-1	ENGINE ROOM UNDER FLOOR	Petrol-powered vehicles <L.H. drive 2WD vehicles with carburetor-5-door models>	2-6	<ul style="list-style-type: none"> A front door switch (B-122) has been added due to the addition of the lighting monitor buzzer.
	3-3		Petrol-powered vehicles <R.H. drive 2WD vehicles with carburetor>	2-8	
	3-4		Petrol-powered vehicles <4WD vehicles with carburetor>	2-10	
	3-5		Petrol-powered vehicles <4WD vehicles with MPI>	2-12	
	3-6		Diesel-powered vehicles <2WD>	2-14	
	3-7		Diesel-powered vehicles <4WD>	2-16	
	3-8		Petrol-powered vehicles <2WD vehicles with MPI>	2-18	
C	4-1	ROOF - TAILGATE - REAR SIDE	5-door models	2-20	<ul style="list-style-type: none"> A cargo room lamp (C-69) has been added.
	4-2		4-door models (without crystal light roof)	2-22	
	4-3		4-door models (with crystal light roof)	2-24	

SINGLE PART INSTALLATION POSITION

Location of change	Vehicle type	Reference page	Description of change
Sensor	4WD vehicles	3-2	A thermometer sensor has been added in line with the addition of the three-meter unit.

Remark

Illustrations of individual components are provided herein only in instances in which the installation location is different than that of former models, or even though the installation location is the same, there is a change of the destination and/or specifications; use this publication, therefore, in combination with the Basic Manual (Pub. No PHWE 8907).

CIRCUIT DIAGRAM

Circuit diagrams				Description of changes
Main title	No.	Subtitle	Ref. page	
3. CHARGING CIRCUIT	3	—	4-3	<ul style="list-style-type: none"> The "AVX3-W" wire has been abolished in line with the alteration of the diameter of the alternator wire.
8. HEADLAMP CIRCUIT	8-1	Vehicles without two bulb united type headlamp	4-4	<ul style="list-style-type: none"> The power circuit has been altered in line with the addition of the lighting monitor buzzer.
	8-2	Vehicles with two bulb united type headlamp	4-6	
9. DAYTIME RUNNING LAMP CIRCUIT	9-1	Vehicles without two bulb united type headlamp	4-8	<ul style="list-style-type: none"> A lighting monitor buzzer (A-127) and a front door switch (B-122) have been added.
	9-2	Vehicles with two bulb united type headlamp	4-10	
10. DIM-DIP LAMP CIRCUIT	10	—	4-12	<ul style="list-style-type: none"> A lighting monitor buzzer (A-127) and a front door switch (B-122) have been added.
11. HEADLAMP LEVELING CIRCUIT	11	—	4-16	<ul style="list-style-type: none"> The power circuit has been altered in line with the addition of the lighting monitor buzzer.
12. TAIL LAMP, POSITION LAMP AND LICENCE PLATE CIRCUIT	12-1	Vehicles without daytime running lamp	4-18	<ul style="list-style-type: none"> A lighting monitor buzzer (A-127) and a front door switch (B-122) have been added.
	12-2	Vehicles with daytime running lamp	4-20	
13. REAR FOG LAMP CIRCUIT	13-1	Vehicles without daytime running lamp	4-24	<ul style="list-style-type: none"> The power circuit has been altered in line with the addition of the lighting monitor buzzer.
	13-2	Vehicles with daytime running lamp	4-26	
14. ROOM LAMP CIRCUIT	14-1	Vehicles without crystal-light roof	4-28	<ul style="list-style-type: none"> A front door switch (B-122) has been added. A cargo room lamp (C-69) has been added.
	14-2	Vehicles with crystal-light roof	4-30	
15. ILLUMINATION LAMP	15	—	4-32	<ul style="list-style-type: none"> A three meter unit has been added.

Circuit diagrams				Description of changes
Main title	No.	Subtitle	Ref. page	
20. METER AND GAUGE CIRCUIT	20-1	Petrol-powered vehicles with carburetor	4-34	<ul style="list-style-type: none"> A three meter unit has been added.
	20-2	Petrol-powered vehicles with MPI	4-36	
	20-3	Diesel-powered vehicles	4-38	
28. AUDIO CIRCUIT	28-1	5 door models	4-40	<ul style="list-style-type: none"> The power circuit has been altered in line with the adoption of an electronic tuning radio.
	28-2	4 door models	4-41	

TABLE OF CIRCUIT DIAGRAMS

This table of circuit diagrams indicates those circuits in which changes and/or additions, etc. have been made; the circuits are here listed in the sequence in which they are presented in the wiring diagrams. Please use this table for reference when following maintenance or repair procedures.

NOTE

- (1) The “●” symbol indicates a circuit in which a change and/or addition has been made.
- (2) The “○” symbol indicates a circuit in which no change has been made. For details please refer to the wiring diagrams.

Main circuit	No.	Circuit classifications	Pub. No. PHWE8907 (Basic)	Pub. No. PHWE8907-1 (Supplement)	Pub. No. PHWE8907-2 (Supplement)
1. STARTING CIRCUIT	1-1	Petrol-powered vehicles	○	○	○
	1-2	Diesel-powered vehicles	○	●	○
2. IGNITION CIRCUIT	2-1	Vehicles without MPI	○	○	○
	2-2	Vehicles with MPI	○	●	○
3. CHARGING CIRCUIT	3	—	○	●	●
4. GLOW CIRCUIT	4-1	Auto glow type	○	●	○
	4-2	Supper quick glow type	○	●	○
5. CARBURETOR CONTROL CIRCUIT	5-1	Vehicles without cold mixture heater	○	●	○
	5-2	Vehicles with cold mixture heater	○	○	○
6. FBC CIRCUIT	6	—	○	●	○
7. MPI CIRCUIT	7	—	○	●	○
8. HEADLAMP CIRCUIT	8-1	Vehicles without two bulb united type headlamp	○	●	●
	8-2	Vehicles with two bulb united type headlamp	—	●	●
9. DAYTIME RUNNING LAMP CIRCUIT	9-1	Vehicles without two bulb united type headlamp	○	●	●
	9-2	Vehicles with two bulb united type headlamp	—	●	●
10. DIM DIP LAMP CIRCUIT	10	—	○	●	●
11. HEADLAMP LEVELING CIRCUIT	11	—	○	●	●
12. TAIL LAMP, POSITION LAMP, LICENSE PLATE LAMP CIRCUIT	12-1	Vehicles without daytime running lamp	○	●	●
	12-2	Vehicles with daytime running lamp	○	●	●
13. REAR FOG LAMP CIRCUIT	13-1	Vehicles without daytime running lamp	○	●	●
	13-2	Vehicles with daytime running lamp	○	●	●
14. ROOM LAMP CIRCUIT	14-1	Vehicles without crystal-light roof	○	●	●
	14-2	Vehicles with crystal-light roof	○	●	●
15. ILLUMINATION LAMP CIRCUIT	15	—	○	●	●
16. TURN-SIGNAL LAMP AND HAZARD LAMP CIRCUIT	16	—	○	●	○
17. STOP LAMP CIRCUIT	17	—	○	●	○
18. BACK-UP LAMP CIRCUIT	18	—	○	●	○
19. HORN CIRCUIT	19	—	○	●	○
20. METER AND GAUGE CIRCUIT	20-1	Petrol-powered vehicles with carburetor	○	●	●
	20-2	Petrol-powered vehicles with MPI	○	●	●
	20-3	Diesel-powered vehicles	○	●	●
	20-4	Engine oil level	—	●	○
21. POWER WINDOW CIRCUIT	21	—	○	●	○
22. CENTRAL LOCKING CIRCUIT	22-1	Rear door and tailgate	○	●	○
	22-2	All doors and tailgate	○	●	○

6

OUTLINE OF CHANGES — Table of Circuit Diagrams

Main circuit	No.	Circuit classifications	Pub. No. PHWE8907 (Basic)	Pub. No. PHWE8907-1 (Supplement)	Pub. No. PHWE8907-2 (Supplement)
23. HEATER CIRCUIT	23-1	5-door models	○	●	○
	23-2	4-door models	○	●	○
24. AIR CONDITIONER CIRCUIT	24-1	Front type (Petrol-powered vehicles)	○	●	○
	24-2	Front type (Diesel-powered vehicles)	○	●	○
	24-3	Front type (Petrol-powered vehicles with large compressor)	○	●	○
	24-4	Front and overhead type (petrol-powered vehicles)	○	●	○
	24-5	Front and overhead type (Diesel-powered vehicles)	○	●	○
25. DEFOGGER CIRCUIT	25	—	○	●	●
26. WIPER AND WASHER CIRCUIT	26-1	Vehicles without rear wiper	○	○	○
	26-2	Vehicles with rear wiper	○	●	○
27. HEAD LAMP WASHER CIRCUIT	27	—	○	●	○
28. AUDIO CIRCUIT	28-1	5-door models	○	●	●
	28-2	4-door models	○	●	●
29. CIGARETTE LIGHTER AND CLOCK CIRCUIT	29	—	○	●	○
30. SUNROOF CIRCUIT	30	—	○	●	○
31. MOTOR DRIVEN ROOF BLIND CIRCUIT	31	—	○	●	○
32. AUTO-CRUISE CONTROL CIRCUIT	32	—	○	●	○
33. HEATED SEAT CIRCUIT	33	—	○	●	○
34. REMOTE CONTROLLED MIRROR CIRCUIT	34	—	○	●	○
35. CENTRALIZED JUNCTION	35	—	○	●	○

2 WIRING HARNESS CONFIGURATION DIAGRAMS

2 INSTRUMENT PANEL

2-1	L.H. drive vehicles	2- 2
2-2	R.H. drive vehicles	2- 4

3 ENGINE ROOM · UNDER FLOOR

3-1	Petrol-powered vehicles <L.H. drive 2WD vehicles with carburetor-5 door models>	2- 6
3-3	Petrol-powered vehicles <R.H. drive 2WD vehicles with carburetor>	2- 8
3-4	Petrol-powered vehicles <4WD vehicles with carburetor>	2-10
3-5	Petrol-powered vehicles <4WD vehicles with MPI>	2-12
3-6	Diesel-powered vehicles <2WD>	2-14
3-7	Diesel-powered vehicles <4WD>	2-16
3-8	Petrol-powered vehicles <2WD vehicles with MPI>	2-18

4 ROOF · TAILGATE · REAR SIDE

4-1	5-door models	2-20
4-2	4-door models (without crystal-light roof)	2-22
4-3	4-door models (with crystal-light roof)	2-24

2 INSTRUMENT PANEL

2-1 L.H. drive vehicles

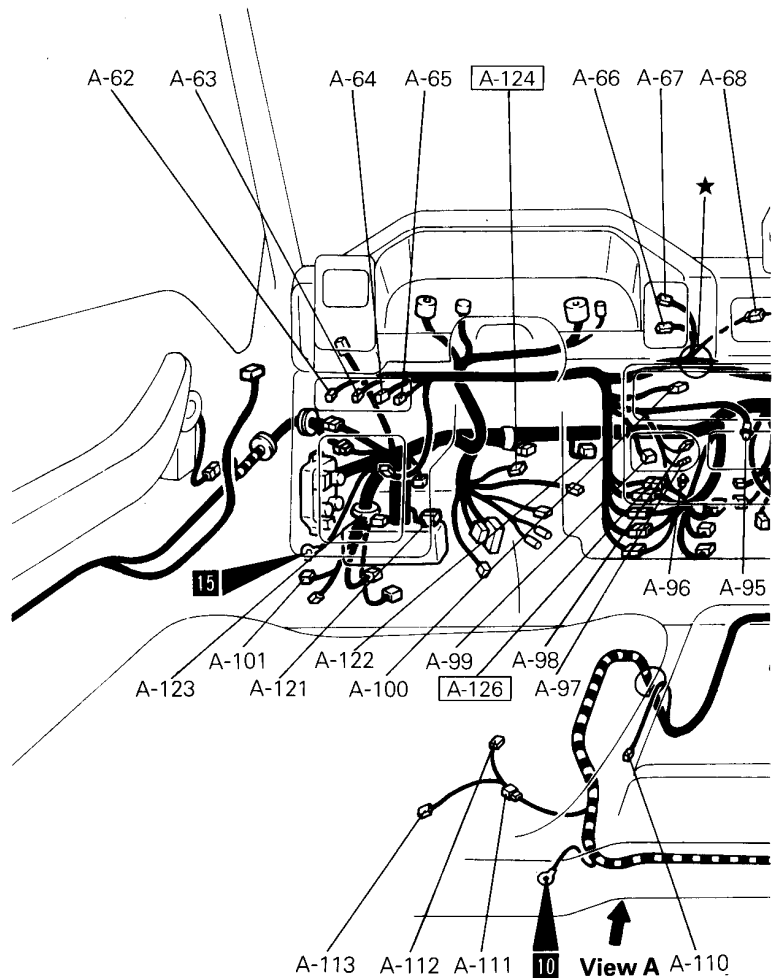
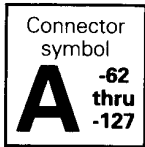

- A-62 Tailgate lock/unlock switch
- A-63 Defogger switch
- A-64 Rear heater blower main switch
- A-65 Rear fog lamp switch
- A-66 Rear wiper and washer switch
- A-67 Hazard warning switch
- A-68 Instrument panel wiring harness and inclinometer wiring harness combination
- A-69 Inclinometer or three-meter unit
- A-70 Clock
- A-71 } Front wiring harness and daytime running lamp wiring harness combination
- A-72 } lamp wiring harness combination
- A-73 Daytime running lamp relay 2
- A-74 Daytime running lamp relay 1
- A-75 } Fin thermostat (Air conditioner)
- A-76 }
- A-77 Rear intermittent wiper relay
- A-78 Front wiring harness and air conditioner wiring harness combination

- A-79 Front speaker (R.H.)
- A-80 Air conditioner relay C
- A-81 } Capacitor (Side)
- A-82 }
- A-83 } Dedicated fuse (Air conditioner)
- A-84 }
- A-85 }
- A-86 Joint (Air conditioner wiring harness)
- A-87 Air conditioner relay A
- A-88 Air conditioner relay B
- A-89 } Capacitor (Tandem)
- A-90 }
- A-91 Diode 1 (Daytime running lamp)
- A-92 Diode 2 (Daytime running lamp)
- A-93 Air conditioner switch
- A-94 Radio
- A-95 Ashtray illumination lamp
- A-96 Cigarette lighter illumination lamp

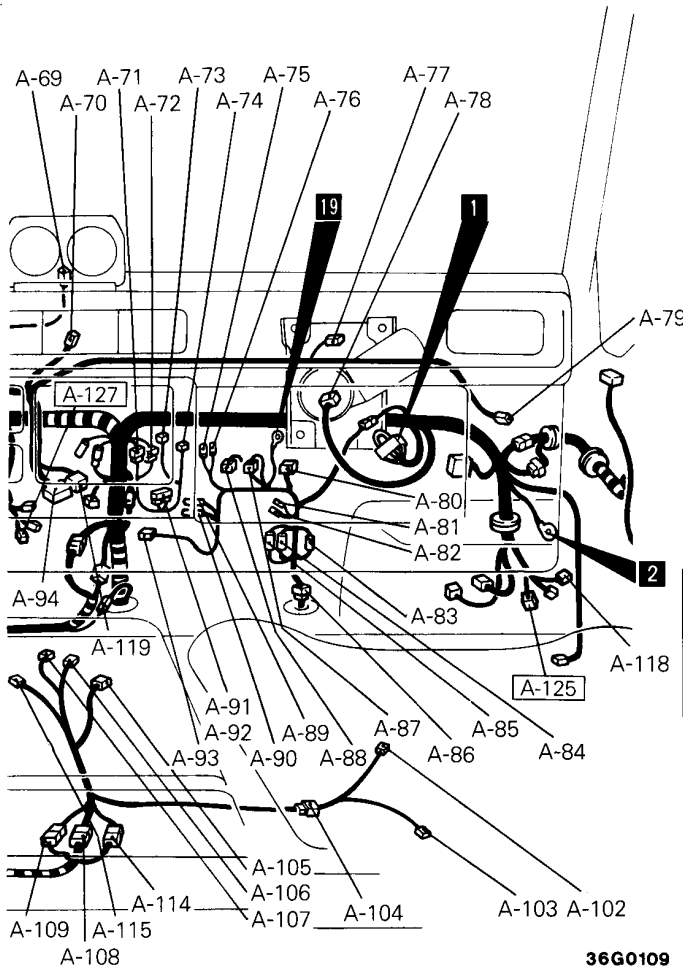

36G0109

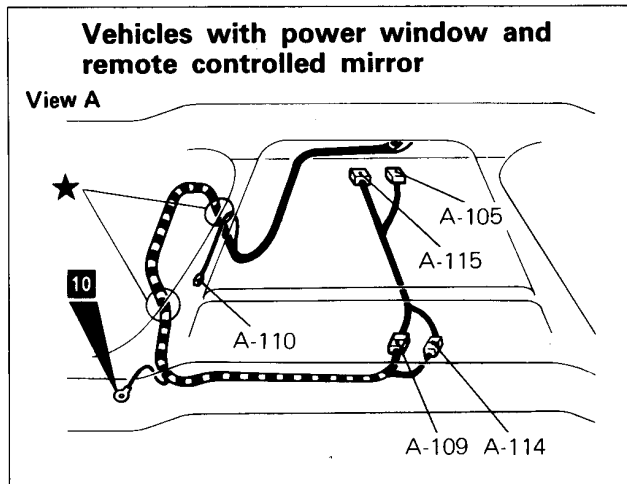

- A-97 } Cigarette lighter
- A-98 }
- A-99 Headlamp leveling switch
- A-100 Front heater blower switch
- A-101 Front speaker (L.H.)
- A-102 Seat cushion (R.H.) [Heated seat]
- A-103 Seat back (R.H.) [Heated seat]
- A-104 Heated seat wiring harness and front floor wiring harness combination
- A-105 Remote controlled mirror switch
- A-106 Heated seat switch (R.H.)
- A-107 Heated seat switch (L.H.)
- A-108 } Front floor wiring harness and console wiring
- A-109 } harness combination
- A-110 Parking brake switch
- A-111 Heated seat wiring harness and front floor wiring harness combination
- A-112 Seat cushion (L.H.) [Heated seat]
- A-113 Seat back (L.H.) [Heated seat]

- A-114 Front floor wiring harness and console wiring harness combination
- A-115 Power window switch
- A-116x } —
- A-117x }
- A-118 Side turn signal lamp (R.H.)
- A-119 Radio
- A-120 —
- A-121 Oil level relay
- A-122 Fuse connector
- A-123 Side turn signal lamp (L.H.)
- A-124 Inside thermometer sensor
- A-125 Outside thermometer sensor
- A-126 Front wiring harness and instrument panel wiring harness combination
- A-127 Buzzer assembly

Remarks

- (1) Connector numbers enclosed by the frame indicate newly added connectors.
- (2) “—” means that the connector with corresponding code number is not used.

2-4 WIRING HARNESS CONFIGURATION DIAGRAMS – Instrument Panel

2-2 R.H. drive vehicles

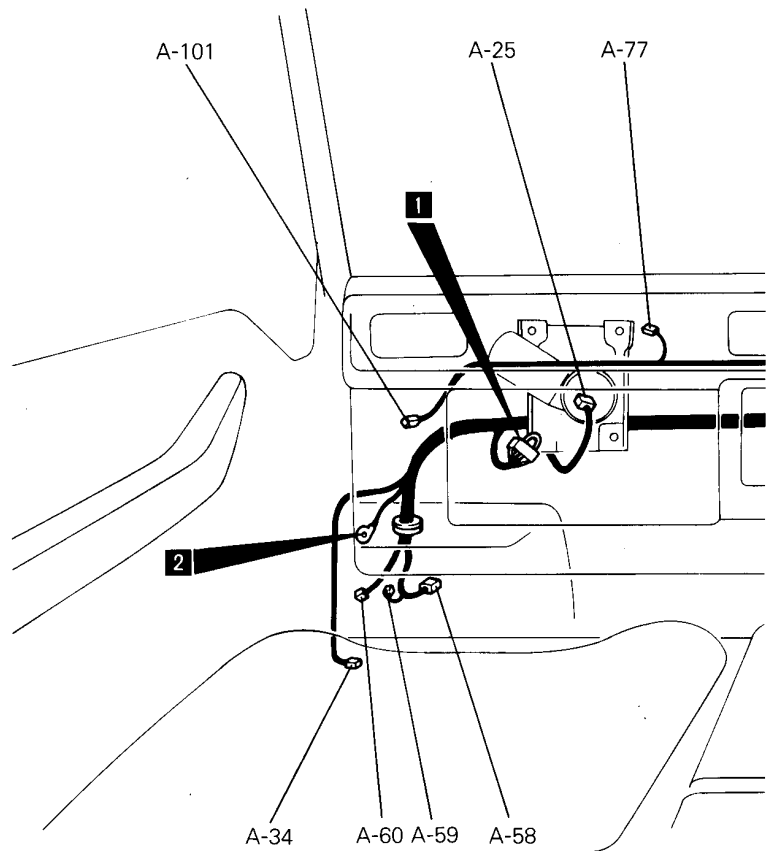
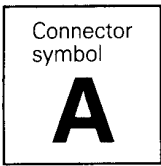

A-01	}	—
thru		
A-05x	}	Headlamp relay
A-06x		
A-07x	}	Defogger relay
A-08x		
A-08x	}	Turn signal and hazard flasher unit
A-09		
thru	}	—
A-11		
A-12	}	Brake fluid level switch
A-13		
A-13	}	Combination meter
A-14		
A-15	}	Condenser
A-16		
A-16	}	Combination meter
A-17		
A-17	}	—
A-18		
A-18	}	—
A-19		
A-19	}	Alternator relay
A-20		
A-20	}	—
A-21		
A-21	}	Front heater blower resistor
A-22		
A-22	}	Front heater blower motor
A-23		
A-23	}	—
A-24		
A-24	}	—
A-25		
A-25	}	Front wiper motor
A-26		
thru	}	—
A-32		
A-32	}	Front combination lamp (R.H.)
A-33		
A-33	}	Front washer motor
A-34		
A-34	}	Headlamp (R.H.)
A-35		

A-36	}	Headlamp leveling unit (R.H.)
A-37		
A-37	}	—
A-40		
A-40	}	Front wiring harness and front floor wiring harness combination
A-41		
A-41	}	—
A-42		
A-42	}	—
A-45		
A-45	}	Front wiring harness and instrument panel wiring harness combination
A-46		
A-46	}	Front wiring harness and instrument panel wiring harness combination
A-47		
A-47	}	—
A-48		
A-48	}	Vacuum switch (Diesel-powered vehicles)
A-49		
A-49	}	—
A-50		
A-50	}	Stop lamp switch
A-51		
A-51	}	—
A-52		
A-52	}	Column switch
A-53		
A-53	}	Ignition switch
A-54		
A-54	}	Dedicated fuse (Headlamp leveling)
A-55		
A-55	}	Headlamp leveling unit (L.H.)
A-56		
A-56	}	Headlamp (L.H.)
A-57		
A-57	}	Front combination lamp (L.H.)
A-58		
A-58	}	—
A-59		
A-59	}	—
A-60		
A-60	}	—
A-61		

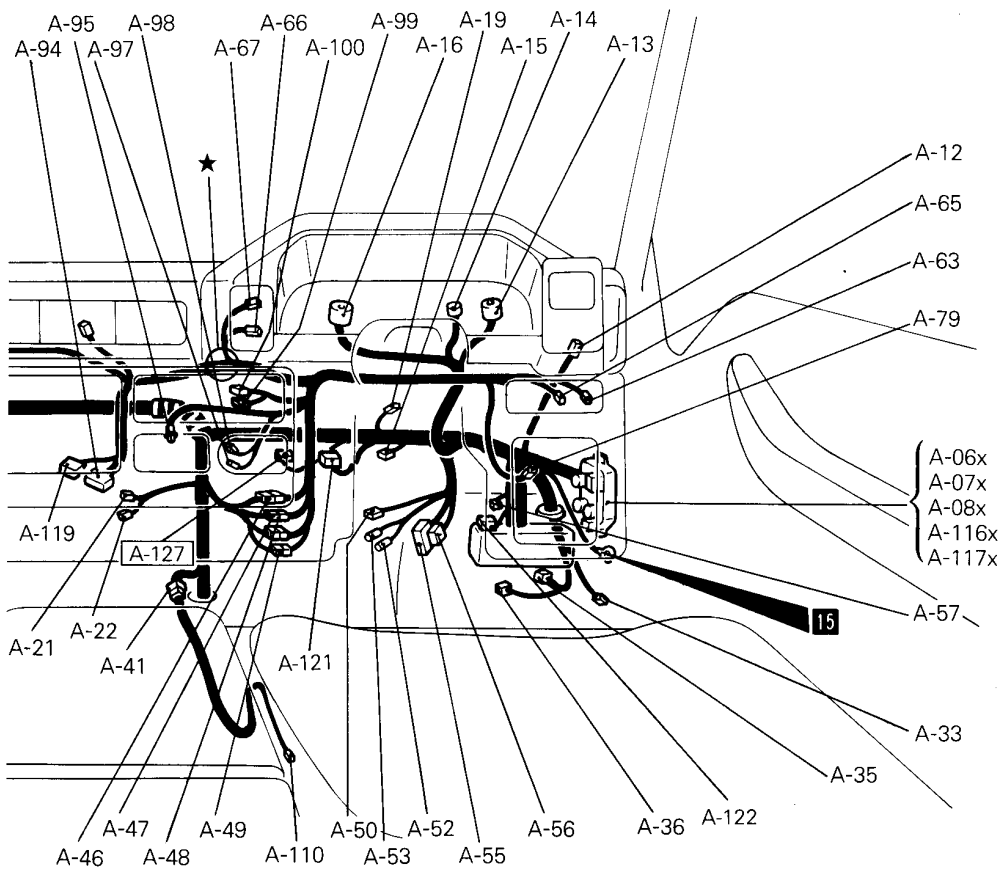

36G0110

- | | | | |
|-----------|-------------------------------|------------|----------------------|
| A-62 | — | A-102 | } — |
| A-63 | Defogger switch | thru A-109 | |
| A-64 | — | A-110 | Parking brake switch |
| A-65 | Rear fog lamp switch | A-111 | } — |
| A-66 | Rear wiper and washer switch | thru A-115 | |
| A-67 | Hazard warning switch | A-116x | Dim-dip lamp relay 1 |
| A-68 | } — | A-117x | Dim-dip lamp relay 2 |
| thru A-76 | | A-118 | — |
| A-77 | Rear intermittent wiper relay | A-119 | Radio |
| A-78 | — | A-120 | — |
| A-79 | Front speaker (R.H.) | A-121 | Oil level relay |
| A-80 | } — | A-122 | Fuse connector |
| thru A-93 | | A-123 | } — |
| A-94 | Radio | thru A-126 | |
| A-95 | Ashtray illumination lamp | A-127 | Buzzer assembly |
| A-96 | — | | |
| A-97 | } Cigarette lighter | | |
| A-98 | | | |
| A-99 | Headlamp leveling switch | | |
| A-100 | Front heater blower switch | | |
| A-101 | Front speaker (L.H.) | | |

- Remarks
- (1) Connector numbers enclosed by the frame 15 indicate newly added connectors.
 - (2) The mark ★ shows the standard mounting position of wiring harness.
 - (3) "—" means that the connector with corresponding code-number is not used.

3 ENGINE ROOM · UNDER FLOOR

3-1 Petrol-powered vehicles <L.H. drive 2WD vehicles with carburetor-5-door models>

Connector
 symbol
B -76
 thru
 -122

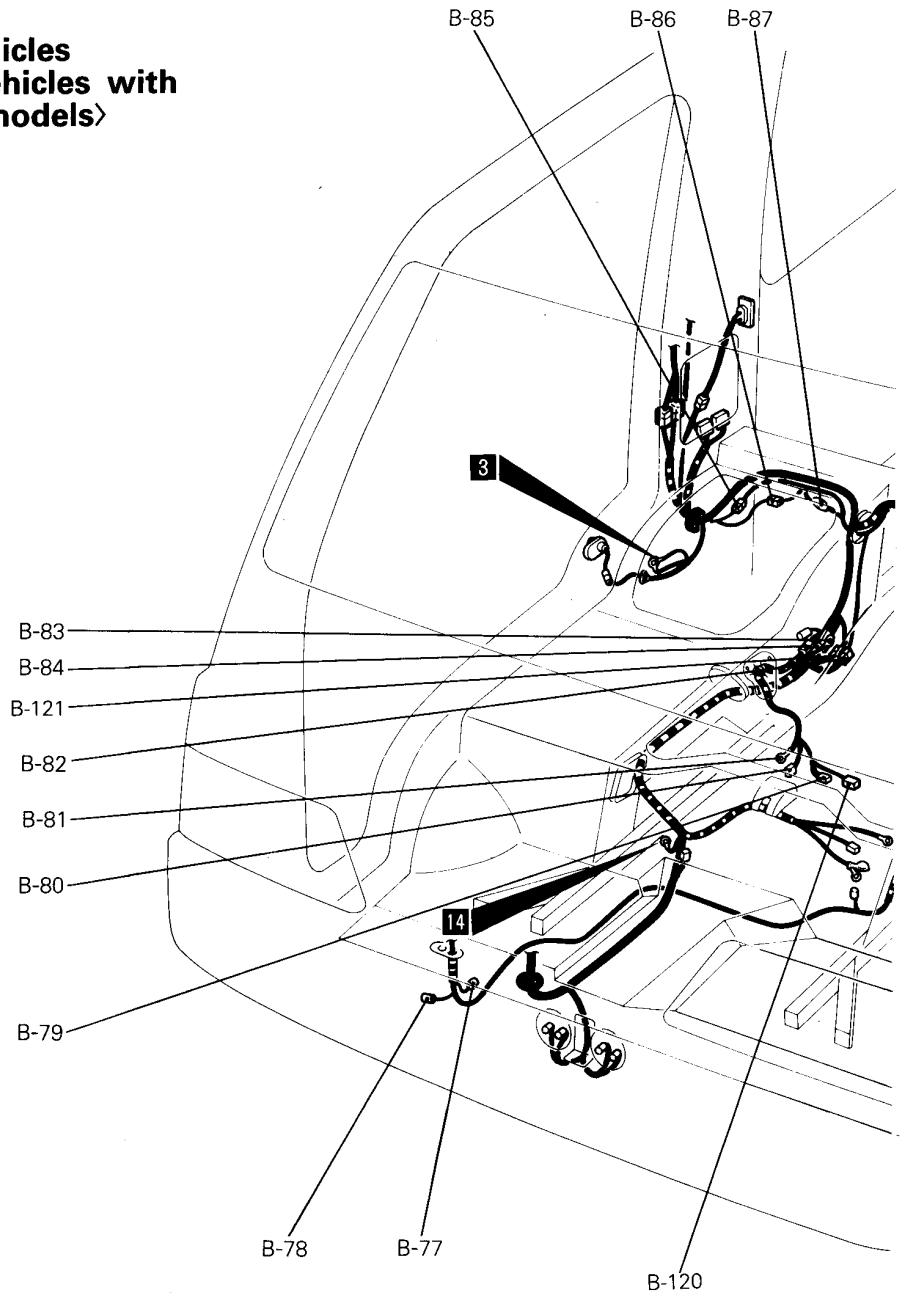

- B-76 —
- B-77 Pressure switch (Dual) (Air conditioner)
- B-78 Condenser fan motor (Air conditioner)
- B-79 Oil pressure switch
- B-80 } Alternator
- B-81 }
- B-82 Front wiring harness and air conditioner wiring harness combination
- B-83 } Front wiring harness and engine wiring harness combination
- B-84 }

- B-85 } Overhead air conditioner wiring harness
- B-86 } and air conditioner harness combination
- B-87 Dedicated fuse (Air conditioner)
- B-88 —
- B-89 —
- B-90 Throttle position sensor
- B-91 Auto choke heater and solenoid valve
- B-92 Solenoid valve (Air conditioner)
- B-93 —
- B-94 Fuel gauge unit

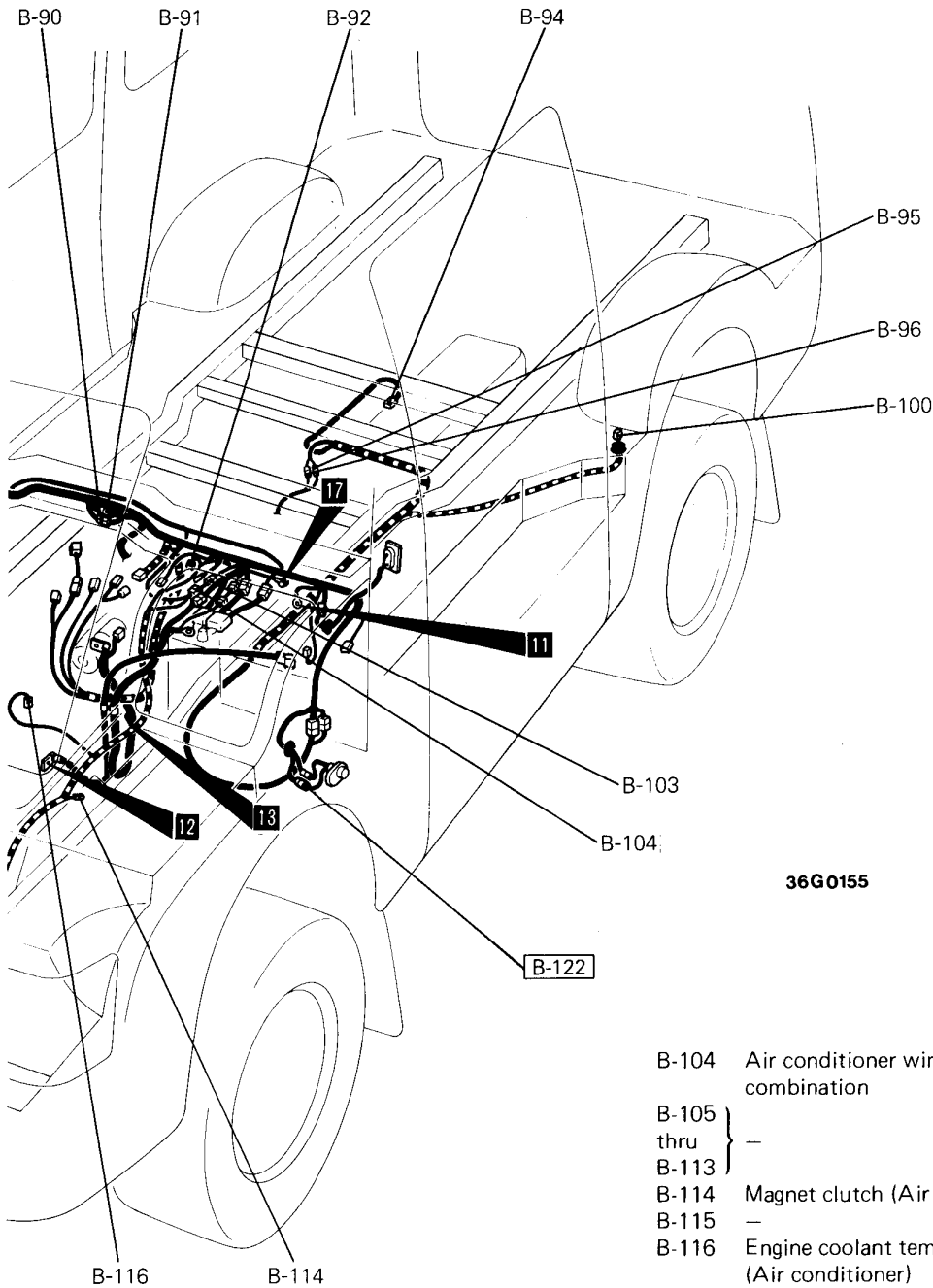

36G0155

- B-95 } Back-up lamp switch
- B-96 } —
- B-97 } —
- thru } —
- B-99 } —
- B-100 Rear heater blower motor
- B-101 —
- B-102 —
- B-103 Front wiring harness and fusible link combination

- B-104 Air conditioner wiring harness and fusible link combination
- B-105 } —
- thru } —
- B-113 } —
- B-114 Magnet clutch (Air conditioner)
- B-115 —
- B-116 Engine coolant temperature switch (Air conditioner)
- B-117 } —
- thru } —
- B-119 } —
- B-120 Engine oil level sensor
- B-121 Front wiring harness and engine wiring harness combination
- B-122 Front door switch (L.H.)

Remarks

- (1) Connector numbers enclosed by the frame indicate newly added connectors.
- (2) "—" means that the connector with corresponding code-number is not used.

3-3 Petrol-powered vehicles
<R.H. drive 2WD vehicles with carburetor>

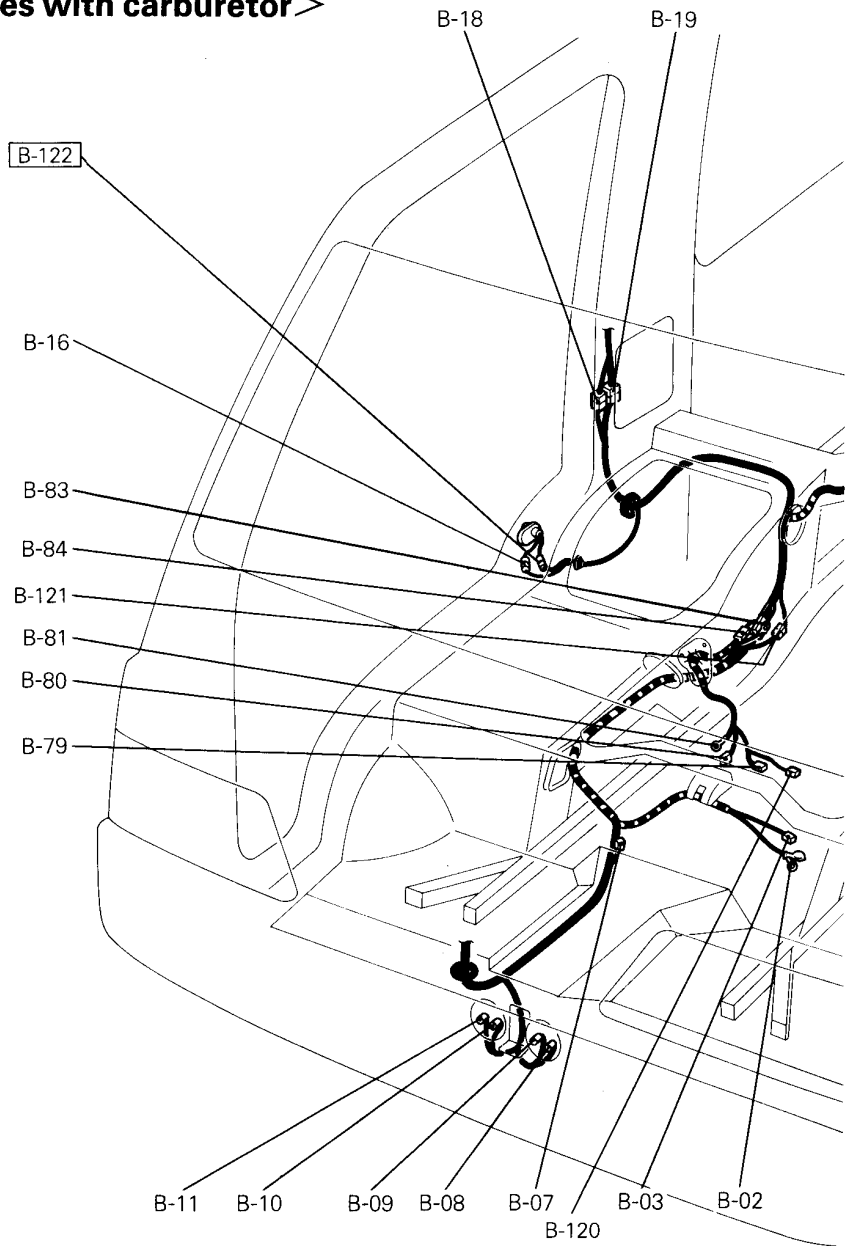
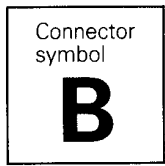

- B-01 —
- B-02 } Ignition coil
- B-03 }
- B-04 } —
- thru }
- B-06 }
- B-07 } Resistor (Vehicles with dim-dip lamp)
- B-08 } —
- thru }
- B-11 } Horn
- B-12 } —
- thru }
- B-15 } —
- B-16 } Front door switch (R.H.)
- B-17 } —
- B-18 } Front wiring harness and roof wiring harness combination
- B-19 }
- B-20 } —
- thru }
- B-43 } —
- B-44 } Fuel cut solenoid valve
- B-45 } Engine coolant temperature gauge unit
- B-46 } —
- thru }
- B-52 }

- B-11
- B-10
- B-09
- B-08
- B-07
- B-03
- B-02
- B-120
- B-53 } Over vent valve
- B-54 } —
- thru }
- B-56 }
- B-57 } Front wiring harness and fusible link box combination
- B-58 }
- B-59 } —
- thru }
- B-62 }
- B-63 } Front wiring harness and fuel gauge wiring harness combination
- B-64 } —

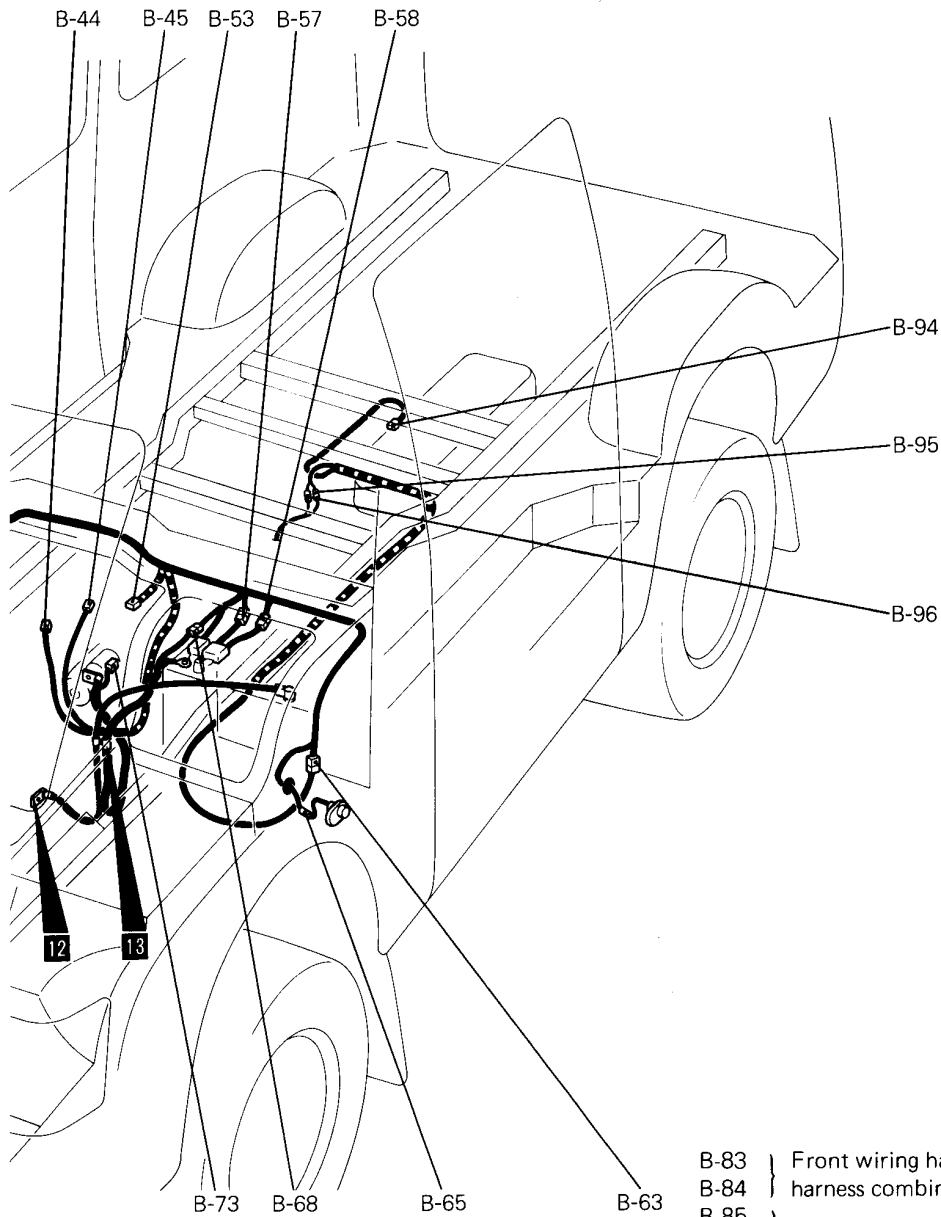

36G0161

- B-65 Front door switch (L.H.)
- B-66 —
- B-67 —
- B-68 Front wiring harness and battery cable (+) combination
- B-69 } —
- thru } —
- B-72 } —
- B-73 Starter
- B-74 } —
- thru } —
- B-78 } —
- B-79 Oil pressure switch
- B-80 } Alternator
- B-81 } —
- B-82 } —

- B-83 } Front wiring harness and engine wiring
- B-84 } harness combination
- B-85 } —
- thru } —
- B-93 } —
- B-94 Fuel gauge unit
- B-95 } Back-up lamp switch
- B-96 } —
- B-97 } —
- thru } —
- B-119 } —
- B-120 Engine oil level sensor
- B-121 Front wiring harness and engine wiring harness combination
- B-122 Front door switch (R.H.)

Remarks

- (1) Connector numbers enclosed by the frame indicate newly added connectors.
- (2) "—" means that the connector with corresponding code-number is not used.

**3-4 Petrol-powered vehicles
<4WD vehicles with carburetor>**

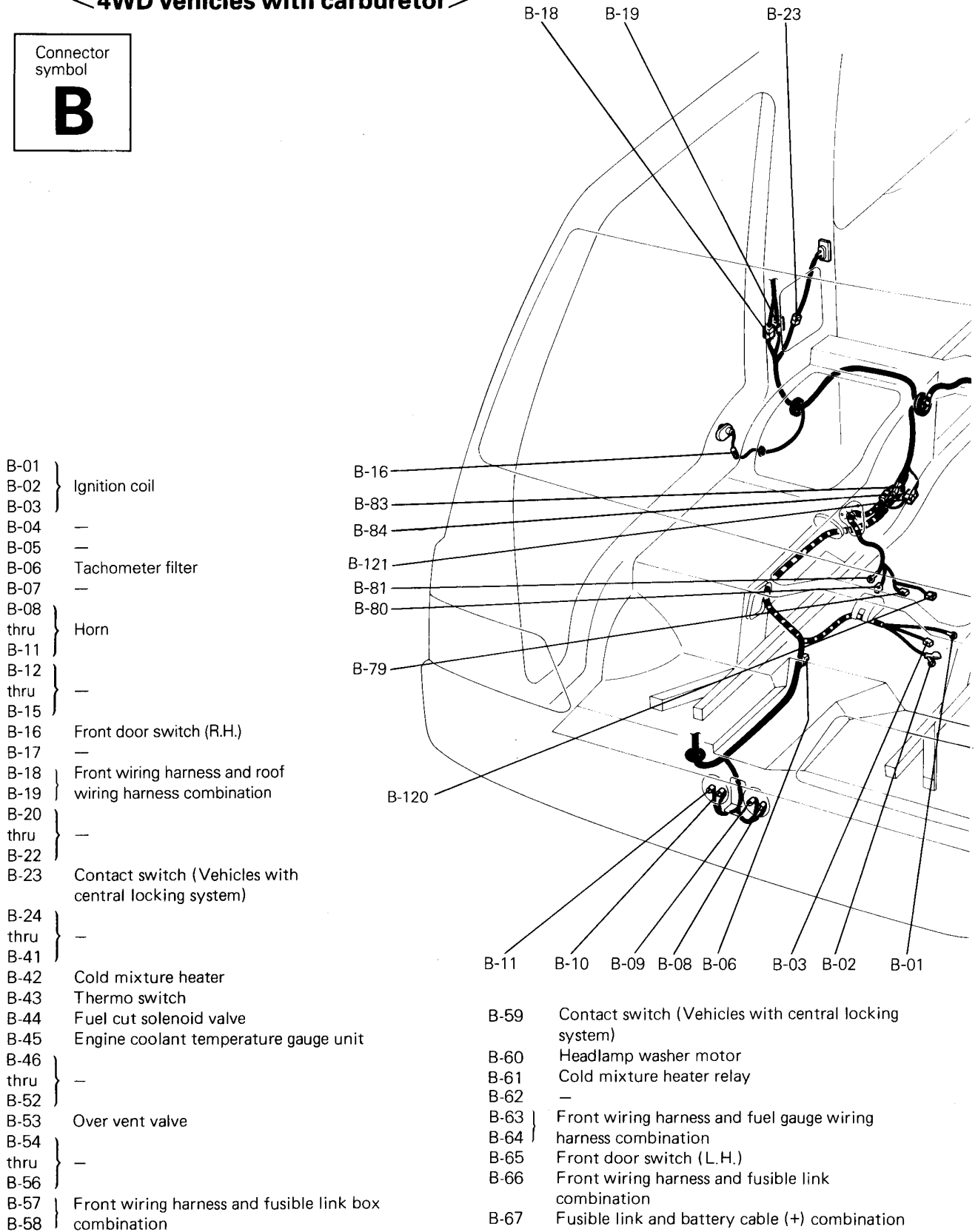
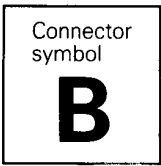

- B-01 } Ignition coil
- B-02 } Ignition coil
- B-03 } Ignition coil
- B-04 } —
- B-05 } —
- B-06 } Tachometer filter
- B-07 } —
- B-08 } —
- B-08 thru B-11 } Horn
- B-11 } —
- B-12 } —
- B-12 thru B-15 } —
- B-15 } —
- B-16 } Front door switch (R.H.)
- B-17 } —
- B-18 } Front wiring harness and roof wiring harness combination
- B-19 } Front wiring harness and roof wiring harness combination
- B-20 } —
- B-20 thru B-22 } —
- B-22 } —
- B-23 } Contact switch (Vehicles with central locking system)
- B-24 } —
- B-24 thru B-41 } —
- B-41 } —
- B-42 } Cold mixture heater
- B-43 } Thermo switch
- B-44 } Fuel cut solenoid valve
- B-45 } Engine coolant temperature gauge unit
- B-46 } —
- B-46 thru B-52 } —
- B-52 } —
- B-53 } Over vent valve
- B-54 } —
- B-54 thru B-56 } —
- B-56 } —
- B-57 } Front wiring harness and fusible link box combination
- B-58 } Front wiring harness and fusible link box combination

- B-11 } —
- B-10 } —
- B-09 } —
- B-08 } —
- B-06 } —
- B-03 } —
- B-02 } —
- B-01 } —
- B-59 } Contact switch (Vehicles with central locking system)
- B-60 } Headlamp washer motor
- B-61 } Cold mixture heater relay
- B-62 } —
- B-63 } Front wiring harness and fuel gauge wiring harness combination
- B-64 } Front wiring harness and fuel gauge wiring harness combination
- B-65 } Front door switch (L.H.)
- B-66 } Front wiring harness and fusible link combination
- B-67 } Fusible link and battery cable (+) combination

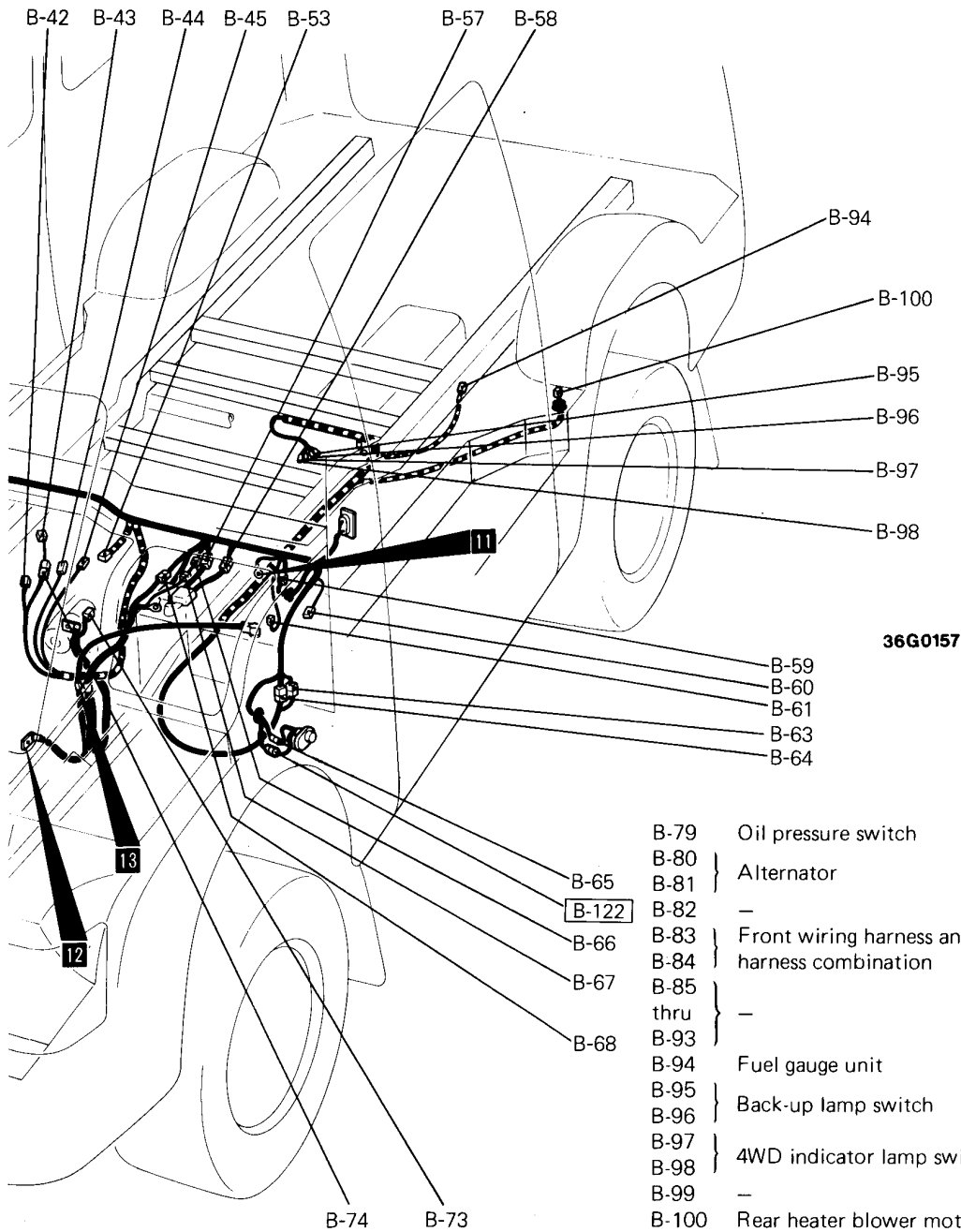

- B-42
- B-43
- B-44
- B-45
- B-53
- B-57
- B-58
- B-59
- B-60
- B-61
- B-63
- B-64
- B-65
- B-66
- B-67
- B-68 } Front wiring harness and battery cable (+) combination
- B-69 } —
- thru B-72 } —
- B-73 } Starter
- B-74 } Front wiring harness and engine wiring harness combination
- B-75 } —
- thru B-78 } —

- B-79 } Oil pressure switch
- B-80 } —
- B-81 } Alternator
- B-82 } —
- B-83 } Front wiring harness and engine wiring harness combination
- B-84 } —
- B-85 } —
- thru B-93 } —
- B-94 } Fuel gauge unit
- B-95 } Back-up lamp switch
- B-96 } —
- B-97 } 4WD indicator lamp switch
- B-98 } —
- B-99 } —
- B-100 } Rear heater blower motor
- B-101 } —
- thru B-119 } —
- B-120 } Engine oil level sensor
- B-121 } Front wiring harness and engine wiring harness combination
- B-122 } Front door switch (L.H.)

Remarks

- (1) Connector numbers enclosed by the frame indicate newly added connectors.
- (2) "—" means that the connector with corresponding code-number is not used.

3-5 Petrol-powered vehicles
 <4WD vehicles with MPI>

Connector
 symbol
B -76
 thru
 -122

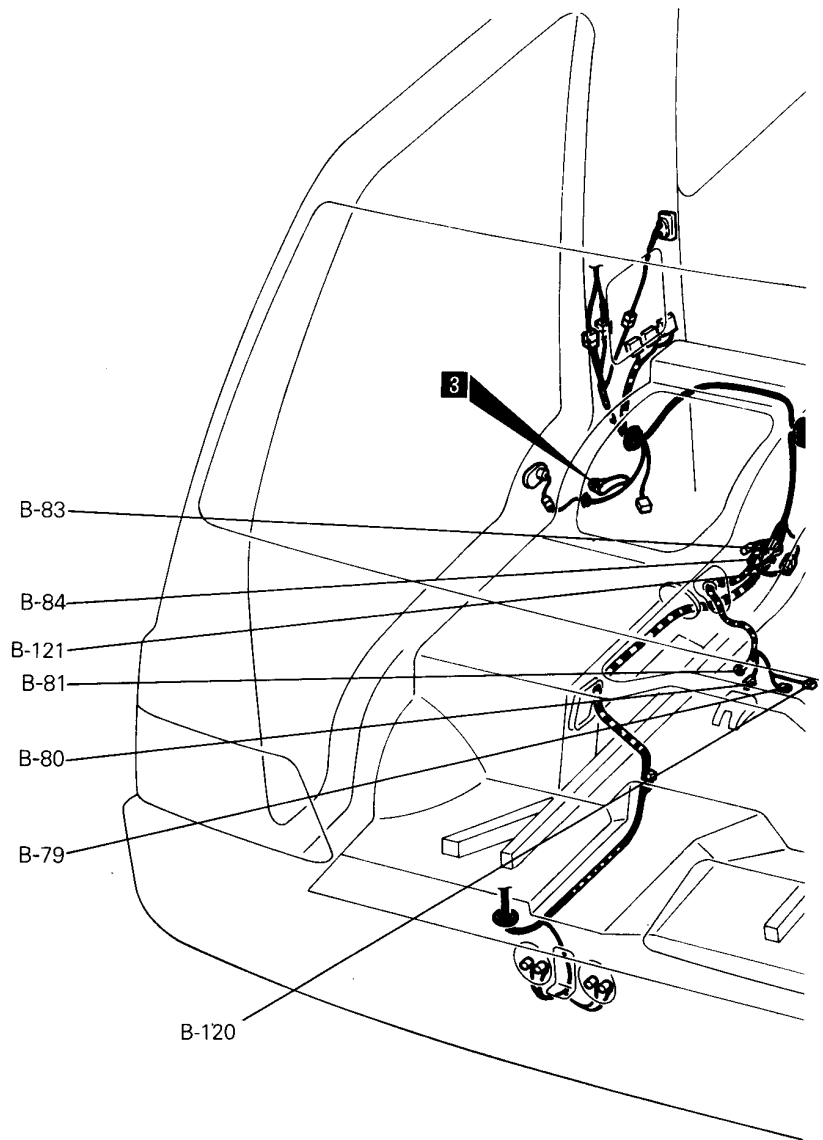

- B-76 } —
- thru } —
- B-78 } —
- B-79 Oil pressure switch
- B-80 } Alternator
- B-81 } —
- B-82 } —
- B-83 } Front wiring harness and engine wiring
- B-84 } harness combination
- B-85 } —
- thru } —
- B-87 } —
- B-88 Front wiring harness and engine wiring
- harness combination
- B-89 Throttle position sensor
- B-90 } —
- thru } —
- B-92 } —
- B-93 Front wiring harness and engine wiring
- harness combination
- B-94 Fuel gauge unit

- B-95 } Back-up lamp switch
- B-96 } —
- B-97 } 4WD indicator lamp switch
- B-98 } —
- B-99 Fuel pump
- B-100 Rear heater blower motor
- B-101 } —
- thru } —
- B-104 } —
- B-105 Power transistor
- B-106 Idle speed control actuator
- B-107 Motor position sensor

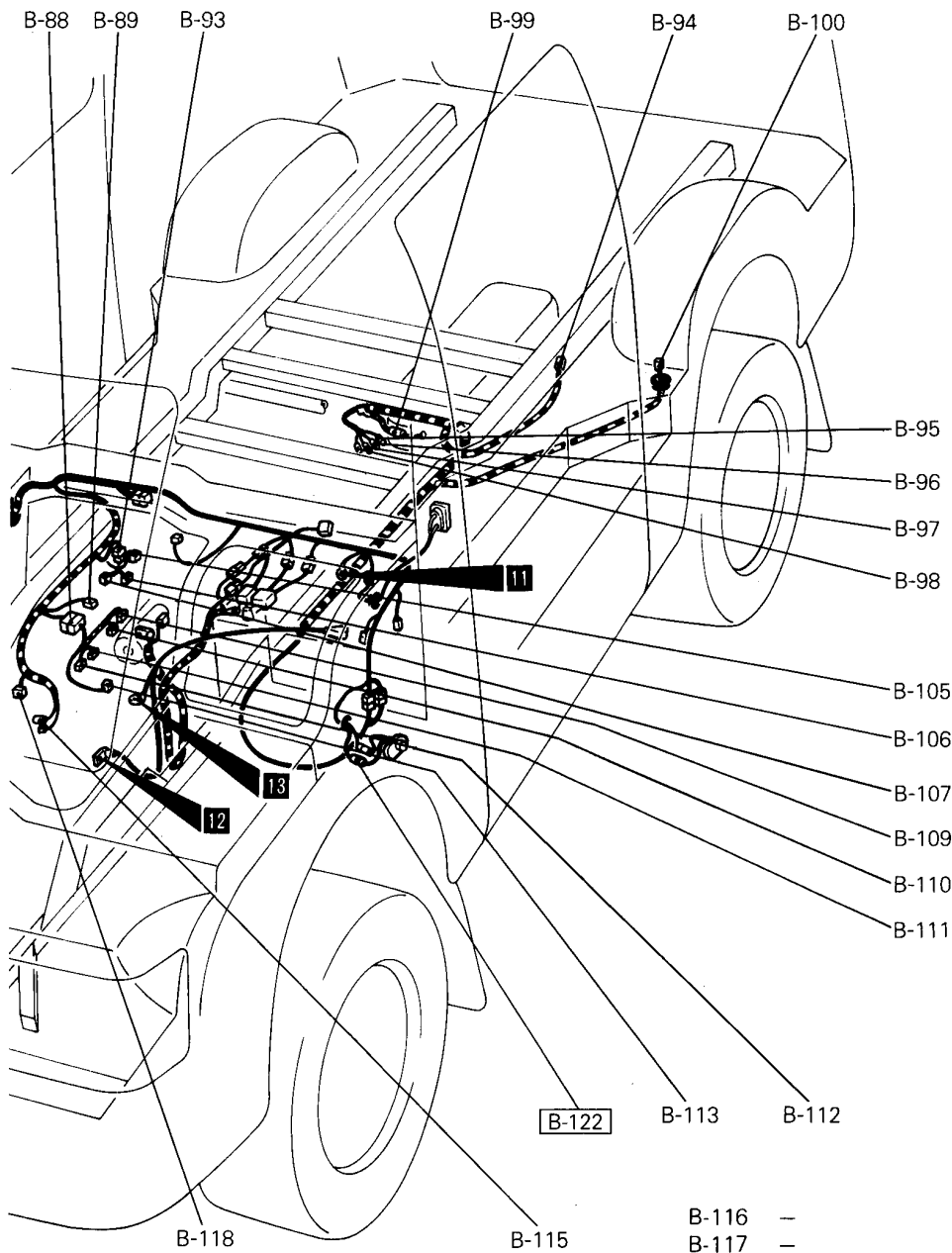

36G0154

- B-108 —
- B-109 Injector 1
- B-110 Injector 2
- B-111 Injector 3
- B-112 Injector 4
- B-113 Ignition coil
- B-114 —
- B-115 Engine coolant temperature sensor

- B-116 —
- B-117 —
- B-118 Distributor (Crank angle sensor and top dead centre sensor)
- B-119—
- B-120 Engine oil level sensor
- B-121 Front wiring harness and engine wiring harness combination
- B-122 Front door switch (L.H.)

Remarks

- (1) Connector numbers enclosed by the frame indicate newly added connectors.
- (2) "—" means that the connector with corresponding code-number is not used.

3-6 Diesel-powered vehicles <2WD>

Connector symbol
B -76 thru -121

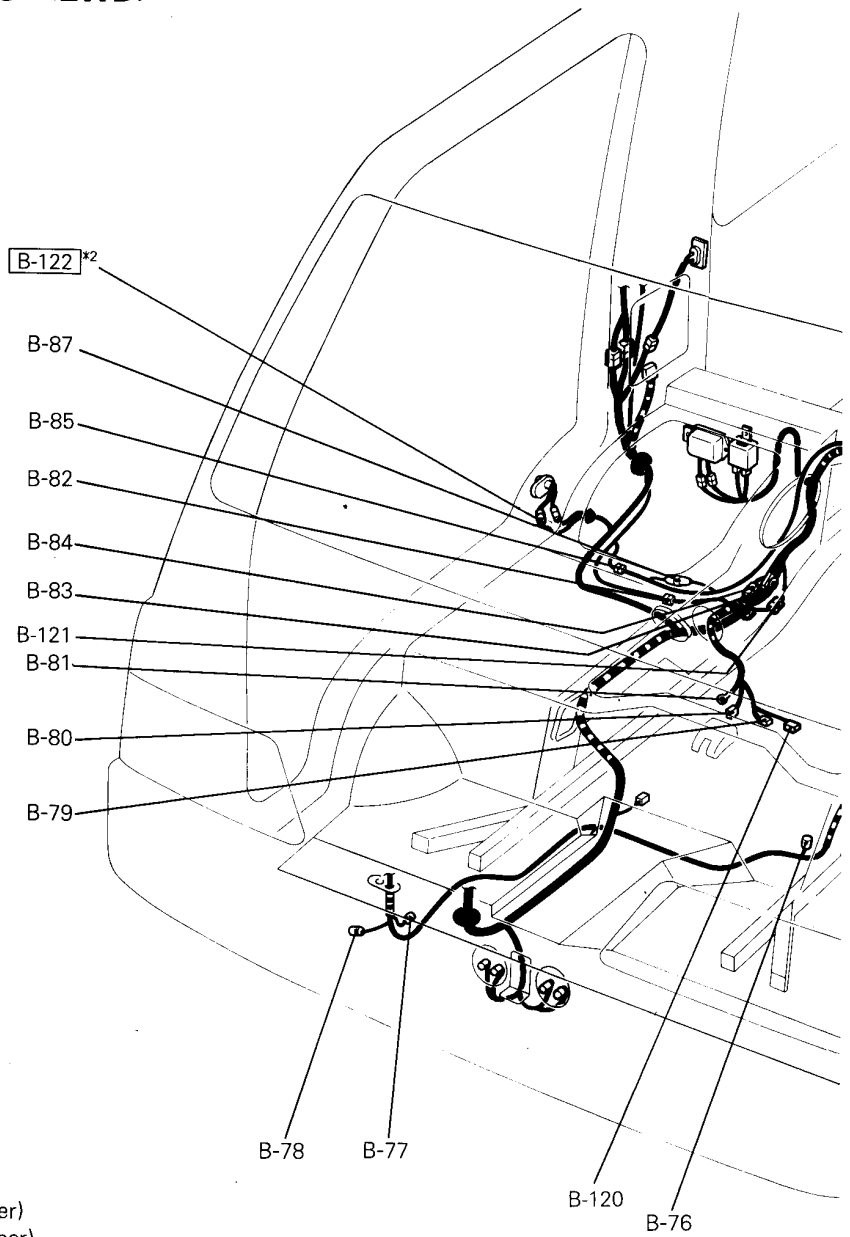

- B-76 Condenser fan motor (Air conditioner)
- B-77 Pressure switch (Dual) (Air conditioner)
- B-78 Condenser fan motor (Air conditioner)
- B-79 Oil pressure switch
- B-80 } Alternator
- B-81 }
- B-82 Front wiring harness and overhead air conditioner wiring harness combination
- B-83 } Front wiring harness and engine wiring
- B-84 } harness combination
- B-85 Overhead air conditioner wiring harness and air conditioner wiring harness combination
- B-86 —
- B-87 Dedicated fuse (Air conditioner)
- B-88 } —
- thru }
- B-93 }

- B-94 Fuel gauge unit
- B-95 } Back-up lamp switch
- B-96 }
- B-97 } —
- thru }
- B-99 }
- B-100 Rear heater blower motor
- B-101 —
- B-102 —
- B-103 Front wiring harness and fusible link combination (Air conditioner)
- B-104 Air conditioner wiring harness and fusible link combination

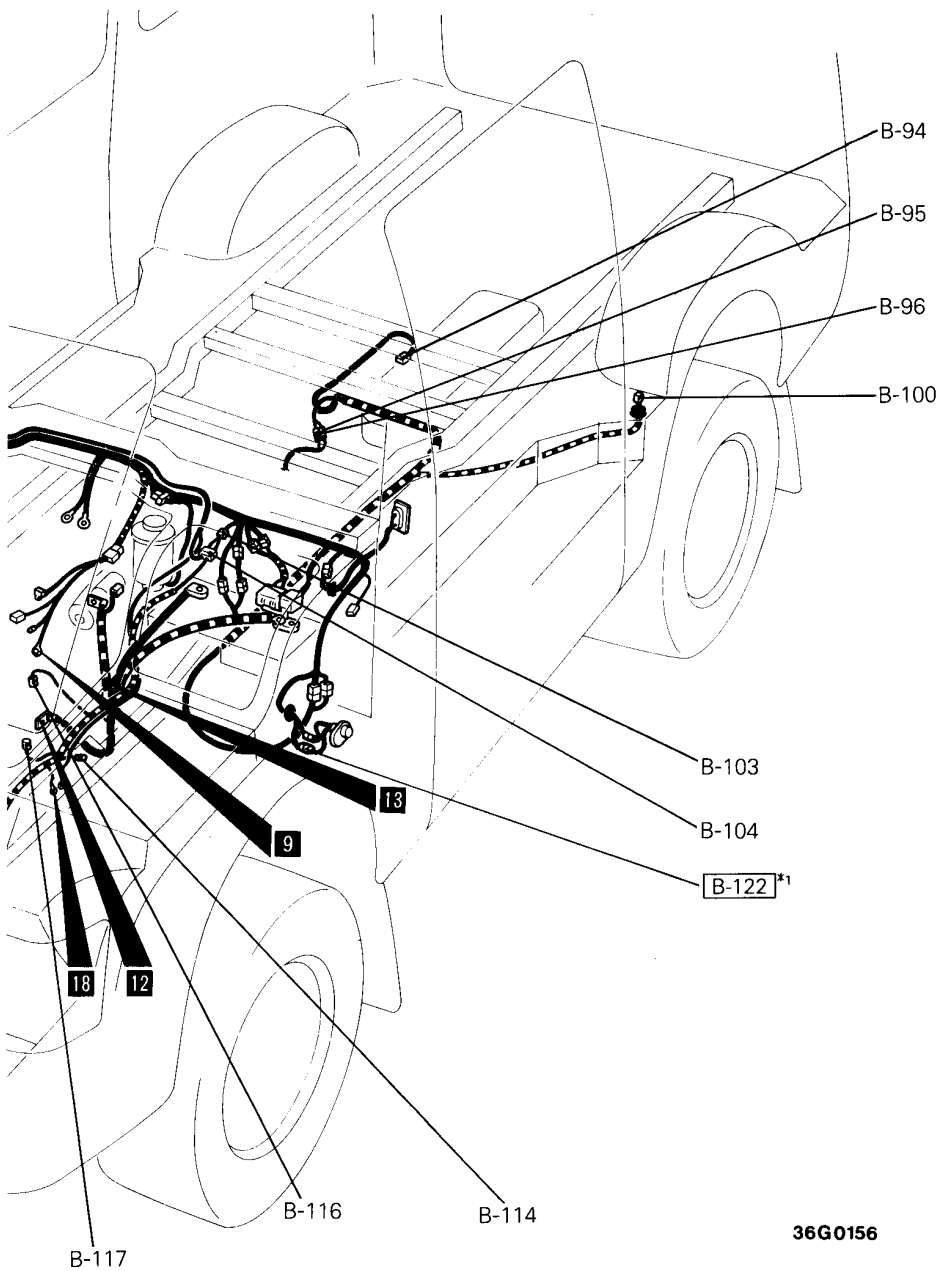

36G0156

- B-105 } —
- thru } —
- B-113 } —
- B-114 Magnet clutch (Air conditioner)
- B-115 —
- B-116 Engine coolant temperature switch
(Air conditioner)
- B-117 Vacuum solenoid valve
- B-118 —
- B-119 —

- B-120 Engine oil level sensor
- B-121 Front wiring harness and engine wiring harness combination
- B-122 Front door switch

Remarks

- (1) Connector numbers enclosed by the frame indicate newly added connectors.
- (2) "—" means that the connector with corresponding code-number is not used.
- (3) *1: L.H. drive vehicles.
- (4) *2: R.H. drive vehicles.

3-7 Diesel-powered vehicles <4WD>

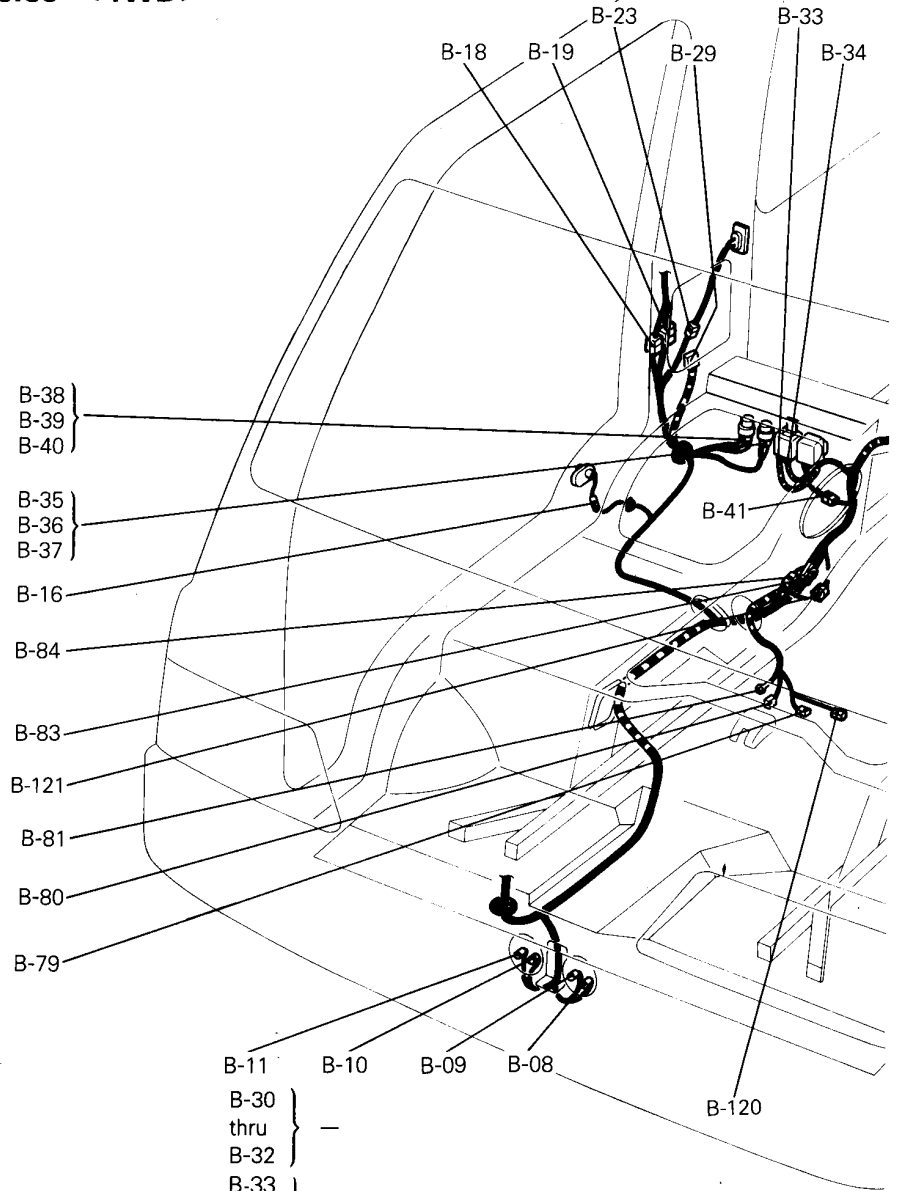
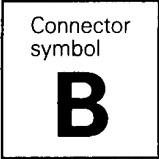

- B-01 } —
- thru } —
- B-07 } —
- B-08 } —
- thru } —
- B-11 } —
- B-12 } —
- thru } —
- B-15 } —
- B-16 } Front door switch (R.H.)
- B-17 } —
- B-18 } Front wiring harness and roof wiring harness
- B-19 } combination
- B-20 } —
- thru } —
- B-22 } —
- B-23 } Contact switch (Vehicles with central locking system)
- B-24 } —
- thru } —
- B-28 } —
- B-29 } Glow control unit

- B-11 } —
- B-10 } —
- B-09 } —
- B-08 } —
- B-30 } —
- thru } —
- B-32 } —
- B-33 } Starter relay
- B-34 } Starter relay
- B-35 } —
- B-36 } Glow relay 1
- B-37 } —
- B-38 } —
- B-39 } Glow relay 2
- B-40 } —
- B-41 } Resistor
- B-42 } —
- thru } —
- B-46 } —
- B-47 } Revolution pick up
- B-48 } Engine coolant temperature gauge unit (Sensor)
- B-49 } —
- B-50 } Glow plug
- B-51 } Front wiring harness and injection pump wiring harness combination

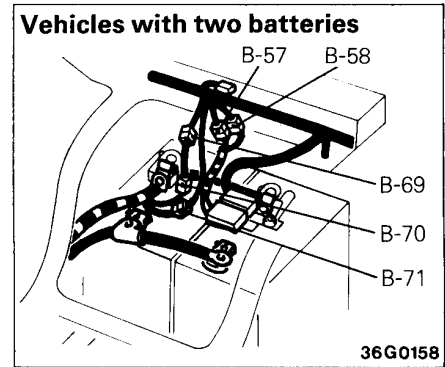
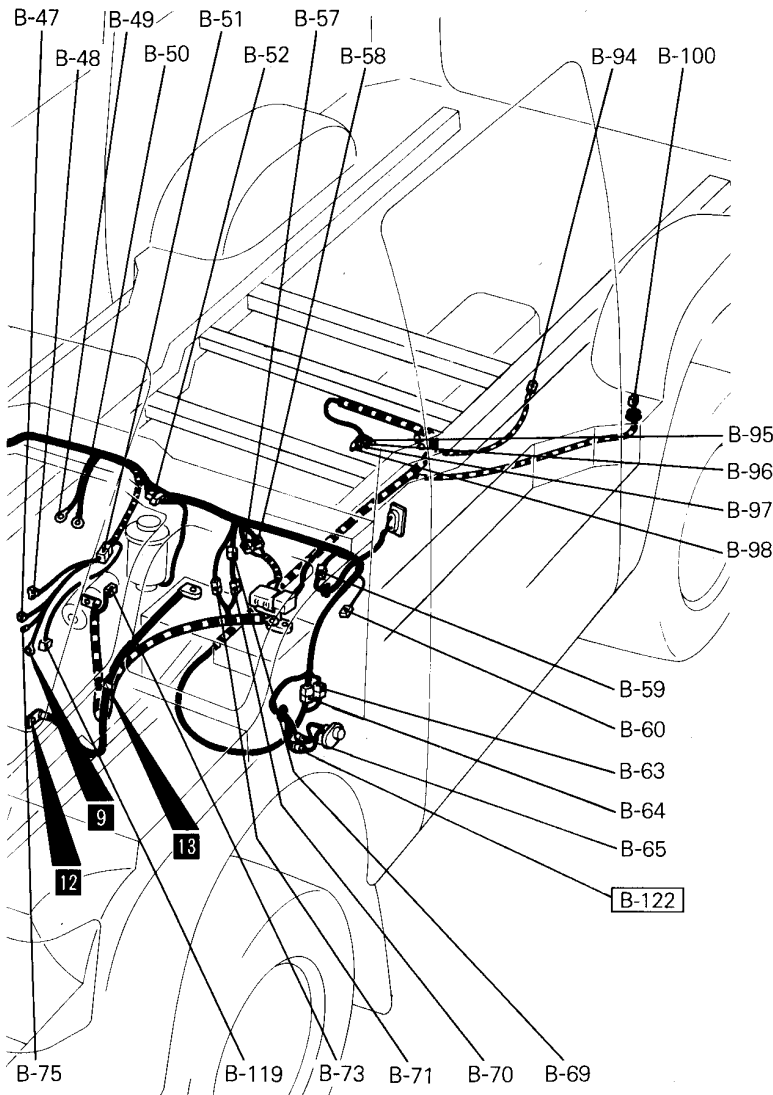

36G0162

36G0158

- B-52 Water level switch
- B-53 } —
- thru } —
- B-56 } —
- B-57 } Front wiring harness and fusible link box
- B-58 } combination
- B-59 Contact switch (Vehicles with central locking system)
- B-60 Headlamp washer motor
- B-61 —
- B-62 —
- B-63 } Front wiring harness and fuel gauge
- B-64 } wiring harness combination
- B-65 Front door switch (L.H.)
- B-66 } —
- thru } —
- B-68 } —
- B-69 Front wiring harness and fusible link combination
- B-70 Fusible link and battery cable (+) combination

- B-71 Front wiring harness and battery cable (+) combination
- B-72 —
- B-73 Starter
- B-74 —
- B-75 Fuel cut solenoid valve
- B-76 } —
- thru } —
- B-78 } —
- B-79 Oil pressure switch
- B-80 } Alternator
- B-81 } —
- B-82 } —
- B-83 } Front wiring harness and engine wiring
- B-84 } harness combination
- B-85 } —
- thru } —
- B-93 } —
- B-94 Fuel gauge unit
- B-95 } Back-up lamp switch
- B-96 } —
- B-97 } 4WD indicator lamp switch
- B-98 } —
- B-99 } —
- B-100 Rear heater blower motor
- B-101 } —
- thru } —
- B-118 } —
- B-119 Engine coolant temperature switch
- B-120 Engine oil level sensor
- B-121 Front wiring harness and engine wiring harness combination
- B-122 Front door switch (L.H.)

Remarks

- (1) Connector numbers enclosed by the frame indicate newly added connectors.
- (2) "—" means that the connector with corresponding code-number is not used.

3-8 Petrol-powered vehicles
 <2WD vehicles with MPI>

Connector
 symbol
B -76
 thru
 -122

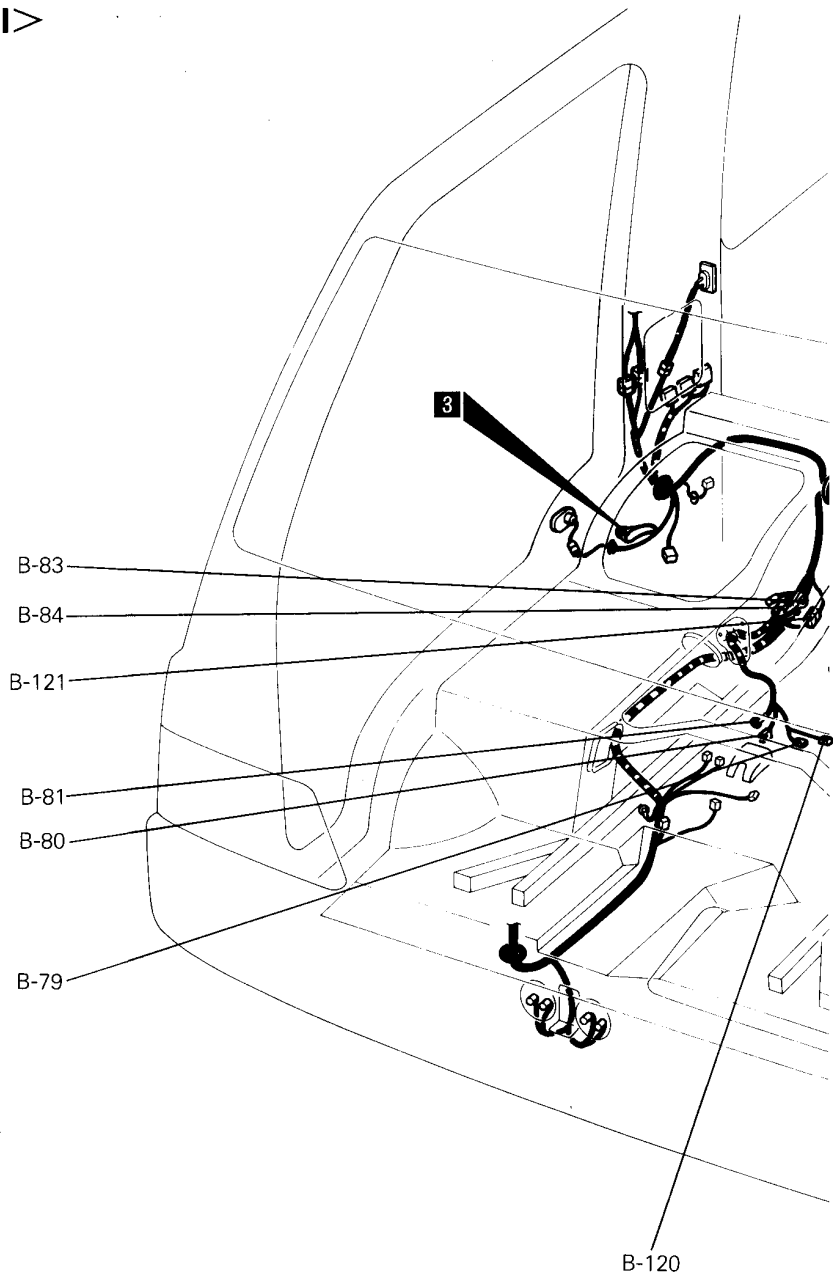

- B-76 } —
- thru } —
- B-78 } —
- B-79 Oil pressure switch
- B-80 } Alternator
- B-81 } —
- B-82 } —
- B-83 Front wiring harness and engine wiring harness combination
- B-84 } —
- B-85 } —
- thru } —
- B-87 } —
- B-88 Front wiring harness and engine wiring harness combination
- B-89 Throttle position sensor
- B-90 } —
- thru } —
- B-92 } —

- B-93 Front wiring harness and engine wiring harness combination
- B-94 Fuel gauge unit
- B-95 } Back-up lamp switch
- B-96 } —
- B-97 } —
- B-98 } —
- B-99 Fuel pump
- B-100 } —
- B-101 } Fuel gauge wiring harness and rear side wiring harness combination
- B-102 } Rear heater blower motor

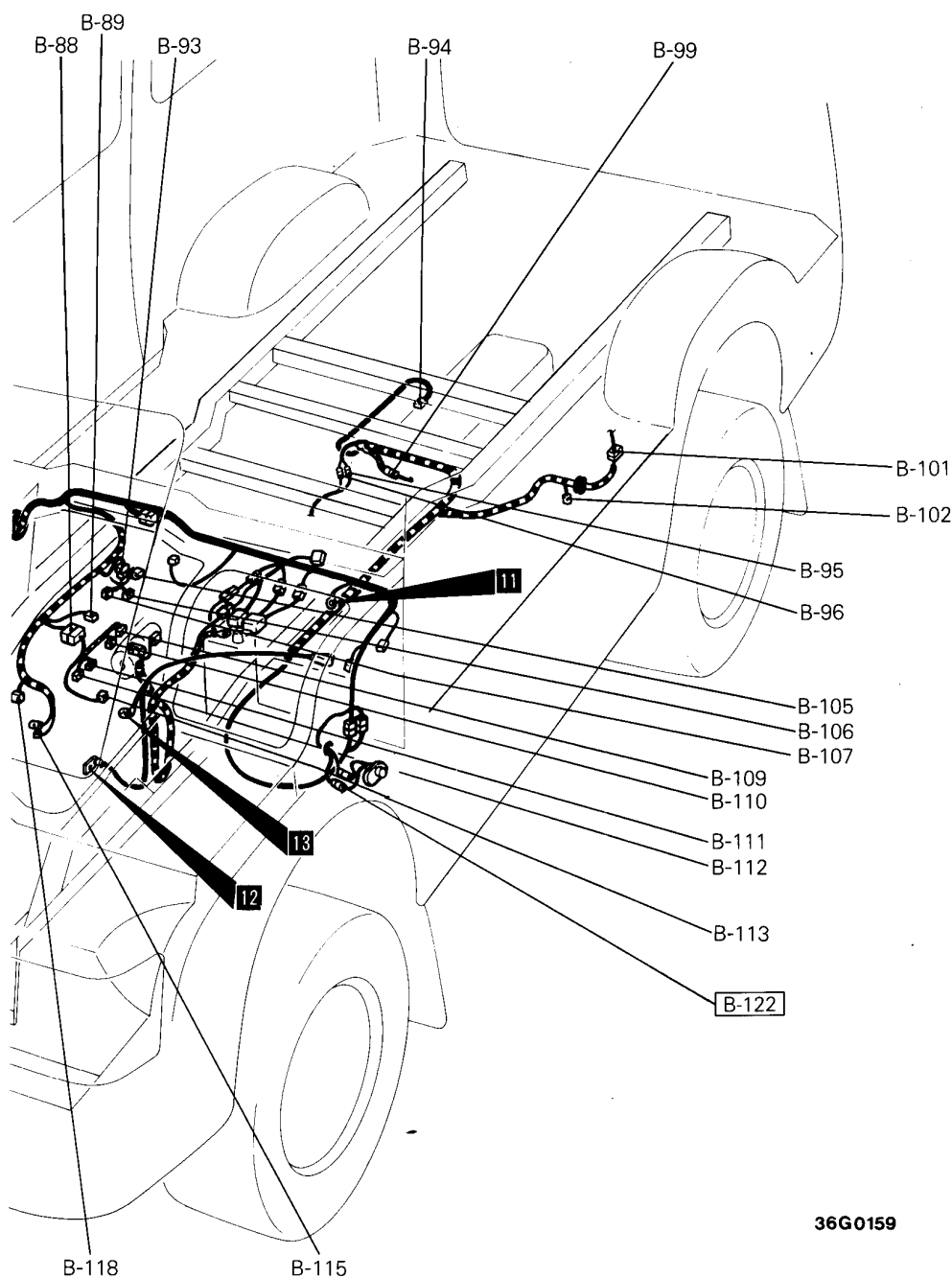

36G0159

- | | | | |
|-------|-----------------------------|--|---|
| B-103 | — | B-115 | Engine coolant temperature sensor |
| B-104 | — | B-116 | — |
| B-105 | Power transistor | B-117 | — |
| B-106 | Idle speed control actuator | B-118 | Distributor (Crank angle sensor and top dead centre sensor) |
| B-107 | Motor position sensor | B-119 | — |
| B-108 | — | B-120 | Engine oil level sensor |
| B-109 | Injector 1 | B-121 | Front wiring harness and engine wiring harness combination |
| B-110 | Injector 2 | B-122 | Front door switch (L.H.) |
| B-111 | Injector 3 | Remark | |
| B-112 | Injector 4 | "—" means that the connector with corresponding code-number is not used. | |
| B-113 | Ignition coil | | |
| B-114 | — | | |

4 ROOF · TAILGATE · REAR SIDE

4-1 5-door models

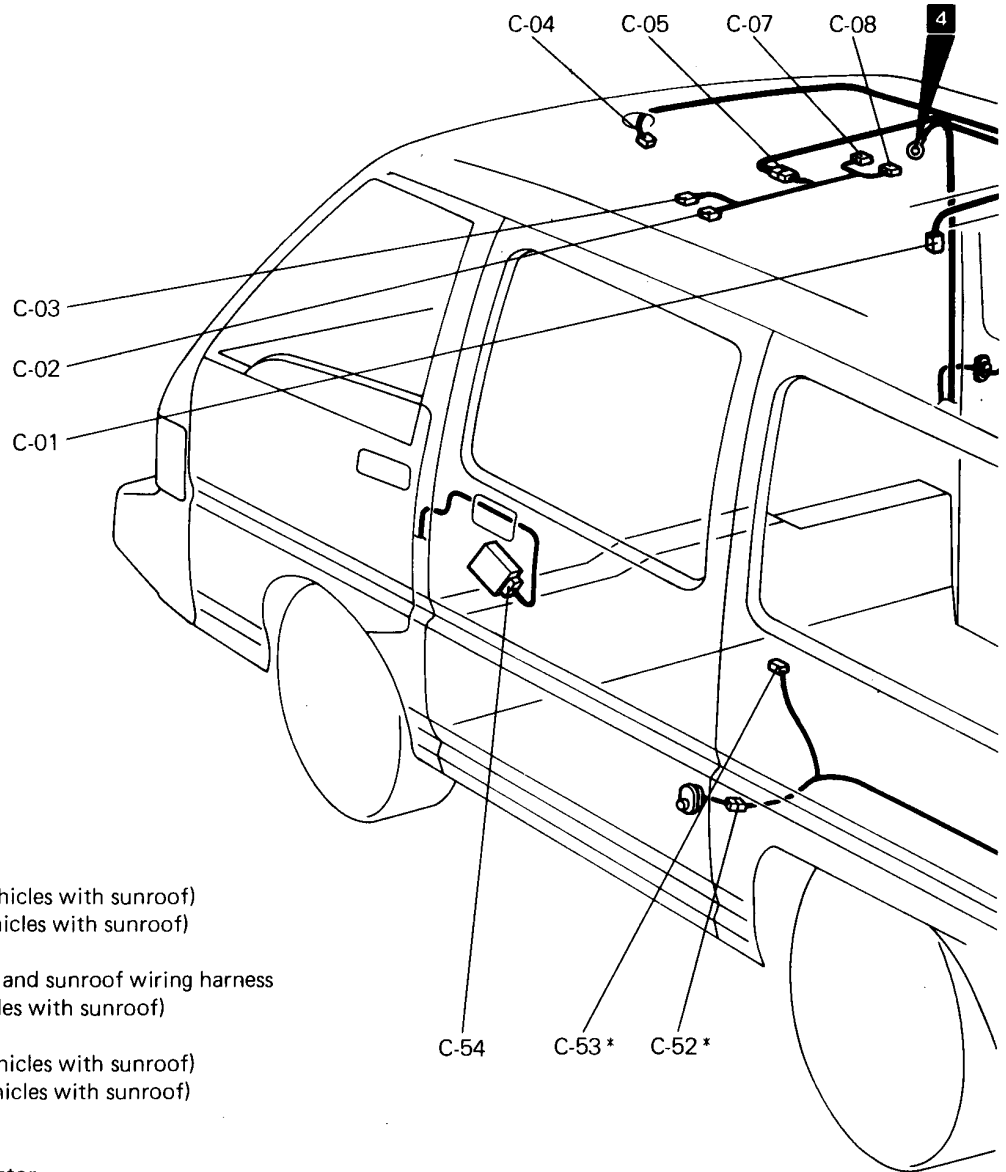
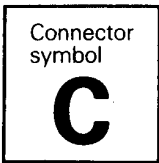

- | | | | |
|------|--|------|--|
| C-01 | Rear room lamp | | |
| C-02 | Sunroof relay 2 (Vehicles with sunroof) | | |
| C-03 | Sunroof motor (Vehicles with sunroof) | | |
| C-04 | Front room lamp | | |
| C-05 | Roof wiring harness and sunroof wiring harness combination (Vehicles with sunroof) | | |
| C-06 | — | | |
| C-07 | Sunroof relay 1 (Vehicles with sunroof) | | |
| C-08 | Sunroof switch (Vehicles with sunroof) | | |
| C-09 | — | | |
| C-10 | — | | |
| C-11 | Rear door lock actuator | | |
| C-12 | } — | | |
| thru | | | |
| C-25 | | | |
| C-26 | | | |
| thru | } Roof wiring harness and tailgate wiring harness combination | | |
| C-29 | | | |
| C-30 | | | |
| C-31 | Defogger (—) | | |
| C-32 | Rear speaker (R.H.) | | |
| C-33 | Rear door switch (R.H.) | | |
| C-34 | Defogger (+) | | |
| C-35 | — | | |
| C-36 | Rear wiper motor | | |
| C-37 | Tailgate lock actuator | | |
| | Door switch wiring harness and roof wiring harness combination | | |
| | | C-38 | Tailgate wiring harness and defogger cable (+) combination |
| | | C-39 | Rear combination lamp (R.H.) |
| | | C-40 | Rear fog lamp (R.H. drive vehicles) |
| | | C-41 | Rear washer motor |
| | | C-42 | Door switch wiring harness and roof wiring harness combination or rear door switch |
| | | C-43 | — |
| | | C-44 | Licence plate lamp (R.H.) |
| | | C-45 | Tailgate lock wiring harness and tailgate wiring harness combination |
| | | C-46 | Tailgate switch |
| | | C-47 | Licence plate lamp (L.H.) |
| | | C-48 | Rear combination lamp (L.H.) |

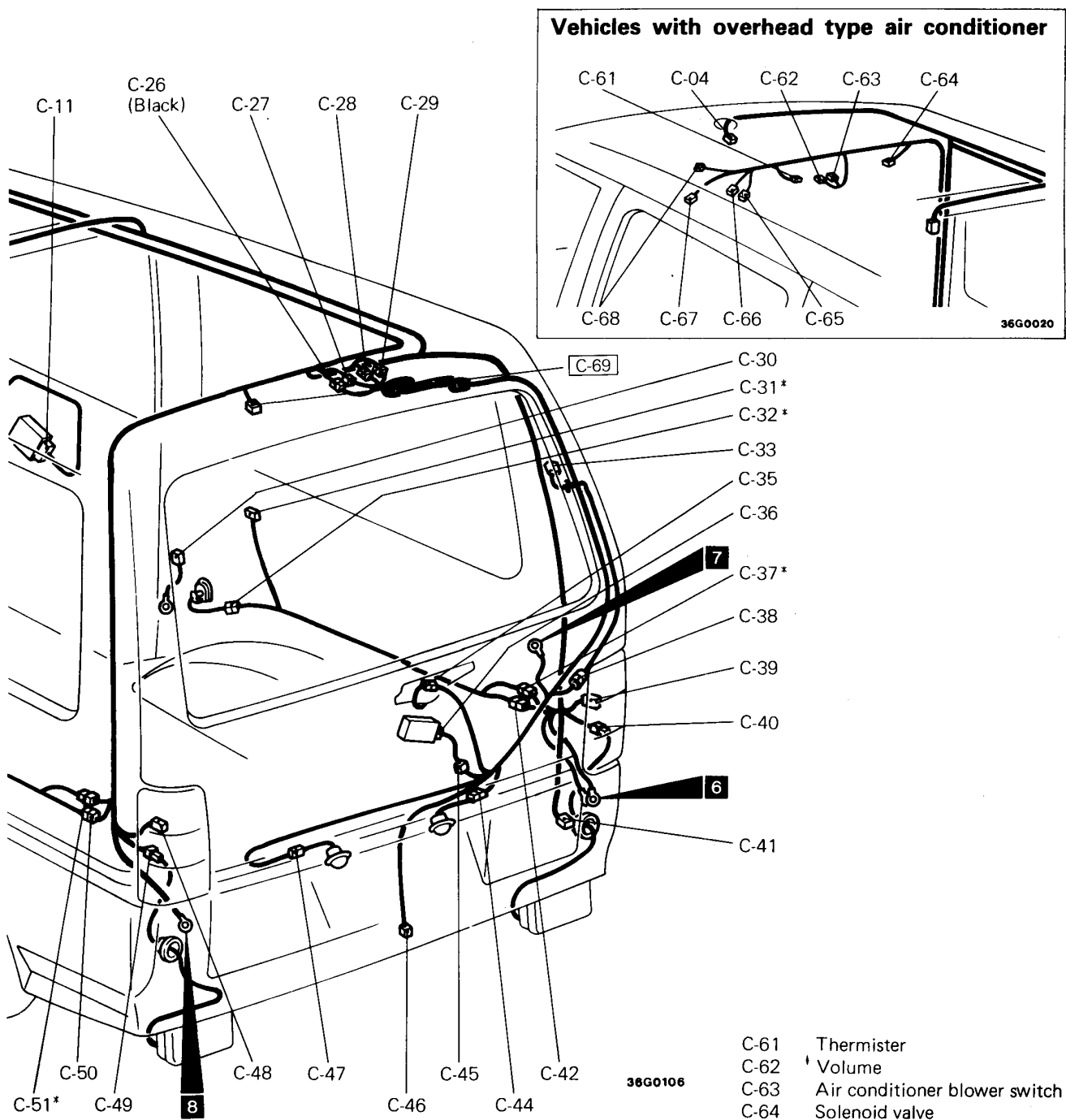

- C-49 Rear fog lamp (L.H. drive vehicles)
- C-50 Door switch wiring harness and roof wiring harness combination* or rear door switch
- C-51 Door switch wiring harness and roof wiring harness combination
- C-52 Rear door switch (L.H.)
- C-53 Rear speaker (L.H.)
- C-54 Rear door lock actuator
- C-55 } —
- thru } —
- C-60 } —

- C-61 Thermister
- C-62 Volume
- C-63 Air conditioner blower switch
- C-64 Solenoid valve
- C-65 Resistor
- C-66 Air conditioner relay D
- C-67 Air conditioner blower motor
- C-68 Thermo relay
- C-69 Cargo room lamp

Remarks

(1) Connector numbers enclosed by the frame indicate newly added connectors.

(2) "—" means that the connector with corresponding code number is not used.

(3) The * symbol indicates vehicles with rear speaker.

4-2 4-door models (without crystal light roof)

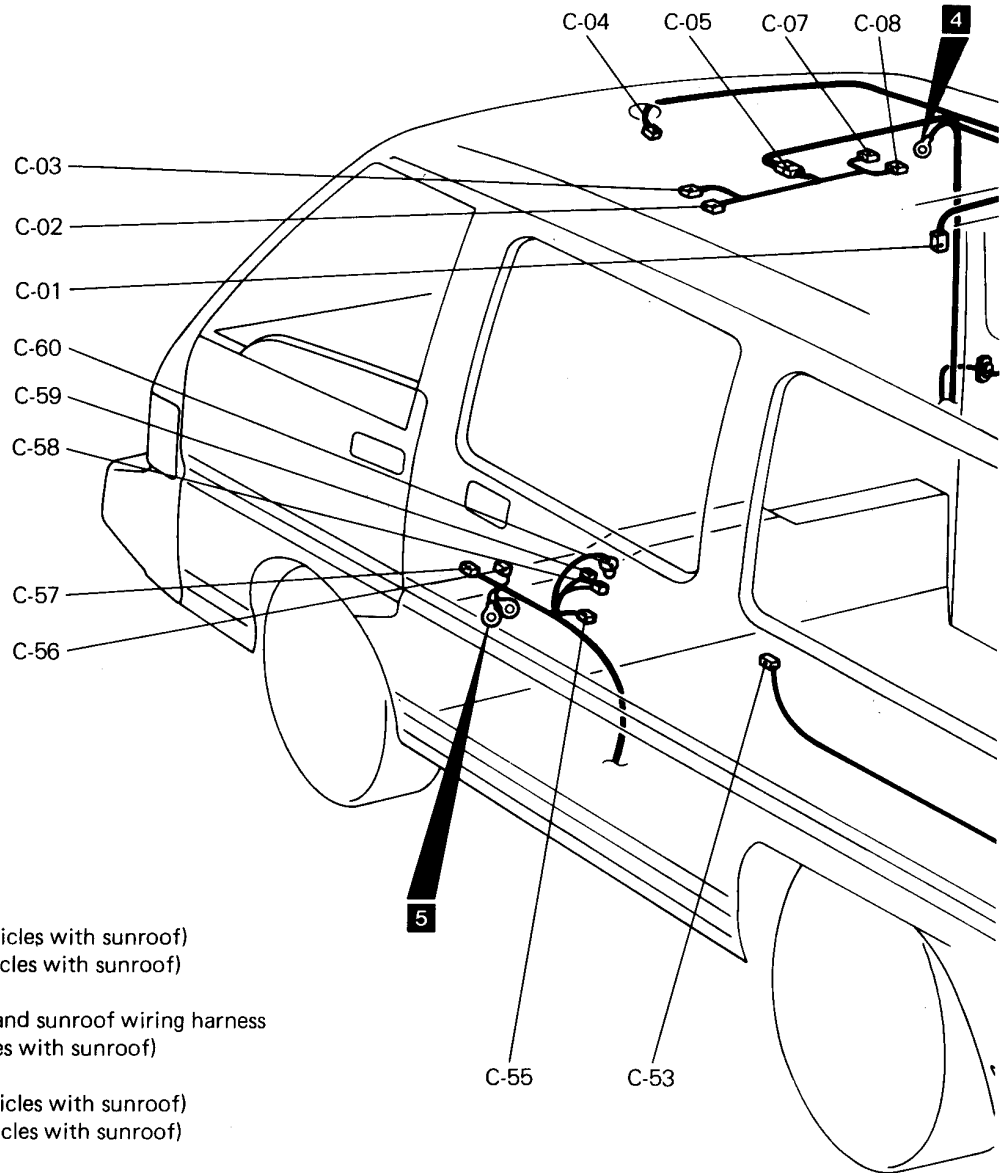
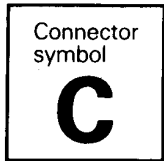

- C-01 Rear room lamp
- C-02 Sunroof relay 2 (Vehicles with sunroof)
- C-03 Sunroof motor (Vehicles with sunroof)
- C-04 Front room lamp
- C-05 Roof wiring harness and sunroof wiring harness combination (Vehicles with sunroof)
- C-06 —
- C-07 Sunroof relay 1 (Vehicles with sunroof)
- C-08 Sunroof switch (Vehicles with sunroof)
- C-09 —
- C-10 —
- C-11 Rear door lock actuator
- C-12 } —
- thru } —
- C-24 } —
- C-25 } Roof wiring harness and tailgate wiring harness
- thru } combination
- C-29 } —
- C-30 Defogger (—)
- C-31 Rear speaker (R.H.)
- C-32 Rear door switch (R.H.)
- C-33 Defogger (+)
- C-34 High-mounted stop lamp
- C-35 Rear wiper motor
- C-36 Tailgate lock actuator
- C-37 Door switch wiring harness and roof wiring harness combination

- C-38 Tailgate wiring harness and defogger cable (+) combination
- C-39 Rear combination lamp (R.H.)
- C-40 No connection
- C-41 Rear washer motor
- C-42 Door switch wiring harness and roof wiring harness combination or rear door switch
- C-43 Tailgate wiring harness and high mounted stop lamp wiring harness combination
- C-44 Licence plate lamp (R.H.)
- C-45 Tailgate lock wiring harness and tailgate wiring harness combination
- C-46 Tailgate switch
- C-47 Licence plate lamp (L.H.)
- C-48 Rear combination lamp (L.H.)

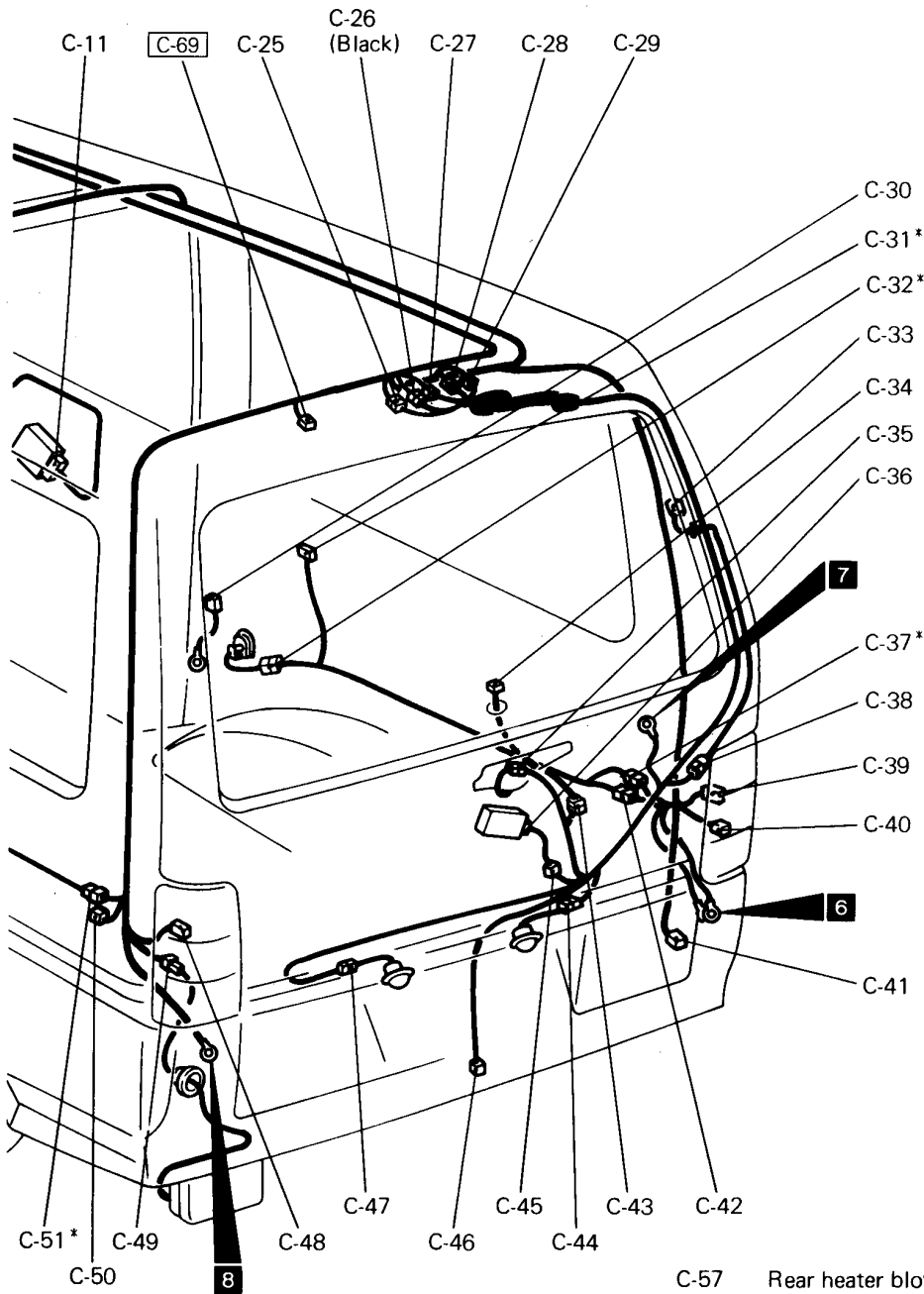

36G0105

- C-49 Rear fog lamp
- C-50 No connection
- C-51 Rear speaker wiring harness and roof wiring harness combination
- C-52 —
- C-53 Rear speaker (L.H.)
- C-54 —
- C-55 No connection
- C-56 Rear heater blower control

- C-57 Rear heater blower sub switch
- C-58 } Rear cigarette lighter
- C-59 } Rear cigarette lighter illumination lamp
- C-60 } —
- C-61 } —
- C-62 } —
- C-63 } —
- C-64 } —
- C-65 } —
- C-66 } —
- C-67 } —
- C-68 } —
- C-69 Cargo room lamp

Remarks

- (1) Connector numbers enclosed by the frame indicate newly added connectors.
- (2) "—" means that the connector with corresponding code-number is not used.
- (3) The * symbol indicates vehicles with rear speaker.

4-3 4-door models (with crystal light roof)

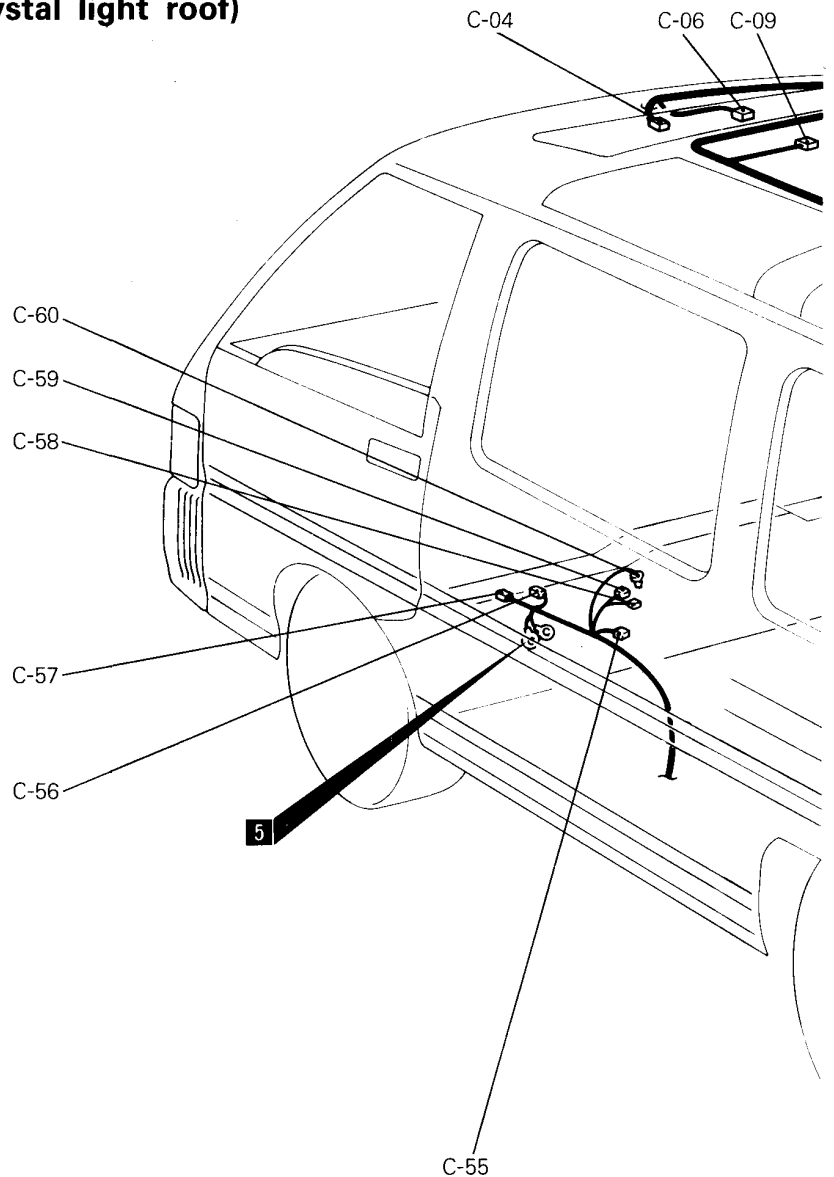
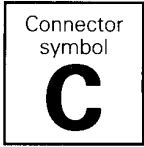

- C-01 } —
- thru } —
- C-03 } —
- C-04 Front room lamp
- C-05 } —
- C-06 Motor-driven roof blind main switch (Front)
- C-07 —
- C-08 —
- C-09 Motor-driven roof blind motor (Front-L.H.)
- C-10 Overhead console lamp
- C-11 Rear door lock actuator (Mini-bus)
- C-12 Motor-driven roof blind motor (Front-R.H.)
- C-13 Motor-driven roof blind sub switch (Rear)
- C-14 Spot lamp
- C-15 } Diode
- thru } (for motor-driven roof blind)
- C-18 } —
- C-19 Motor-driven roof blind motor (Rear-L.H.)
- C-20 } Motor-driven roof blind relay
- thru } —
- C-23 } —
- C-24 Motor-driven roof blind motor (Rear-R.H.)
- C-25 No connection
- C-26 } Roof wiring harness and tailgate wiring harness combination
- thru } —
- C-29 } —
- C-30 Defogger (-)
- C-31 Rear speaker (R.H.)
- C-32 Rear door switch
- C-33 Defogger (+)
- C-34 —

- C-35 Rear wiper motor
- C-36 Tailgate lock actuator
- C-37 Door switch wiring harness and roof wiring harness combination
- C-38 Tailgate wiring harness and defogger cable (+) combination
- C-39 Rear combination lamp (R.H.)
- C-40 —
- C-41 Rear washer motor
- C-42 Door switch wiring harness and roof wiring harness combination or rear door switch
- C-43 —
- C-44 Licence plate lamp (R.H.)
- C-45 Tailgate lock wiring harness and tailgate wiring harness combination
- C-46 Tailgate switch

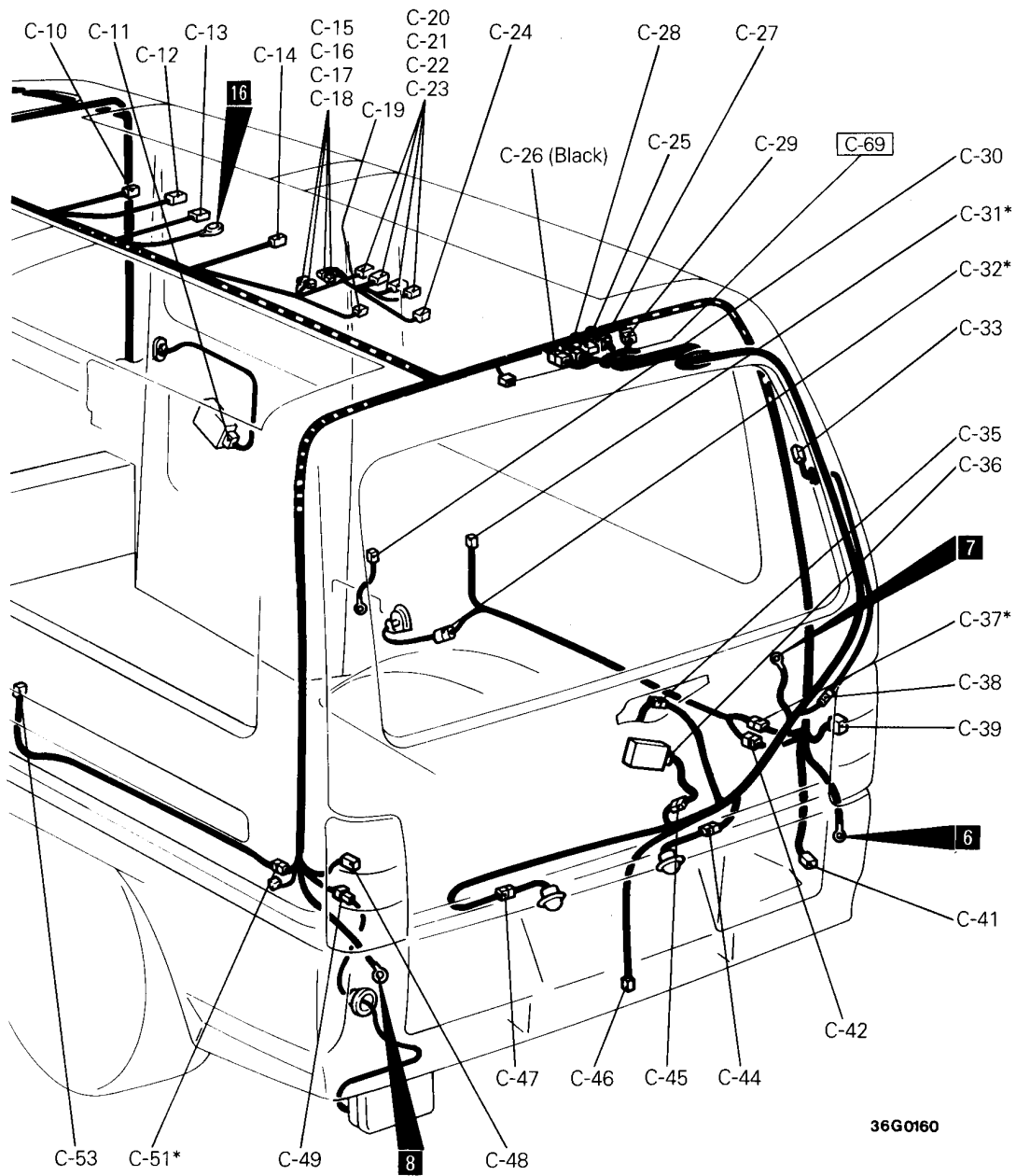

36G0160

- C-47 Licence plate lamp (L.H.)
- C-48 Rear combination lamp (L.H.)
- C-49 Rear fog lamp
- C-50 —
- C-51 Rear speaker wiring harness and roof wiring harness combination
- C-52 —
- C-53 Rear speaker (L.H.)
- C-54 —
- C-55 No connection
- C-56 Rear heater blower control
- C-57 Rear heater blower sub switch
- C-58 } Rear cigarette lighter
- C-59 }

- C-60 Rear cigarette lighter illumination lamp
- C-61 } —
- thru } —
- C-68 } —
- C-69 Cargo room lamp

Remarks

- (1) Connector numbers enclosed by the frame indicate newly added connectors.
- (2) "—" means that the connector with corresponding code-number is not used.
- (3) The * symbol indicates vehicles with rear speaker.

3 SINGLE PART INSTALLATION POSITION

SENSOR MOUNTING LOCATIONS 3- 2

3-2 SINGLE PART INSTALLATION POSITION — Sensor Mounting Locations

SENSOR MOUNTING LOCATIONS

Name	Symbol
Inside thermometer sensor (4WD vehicles)	A
Outside thermometer sensor (4WD vehicles)	B

Remark
The "Name" column is arranged in alphabetical order.

Interior

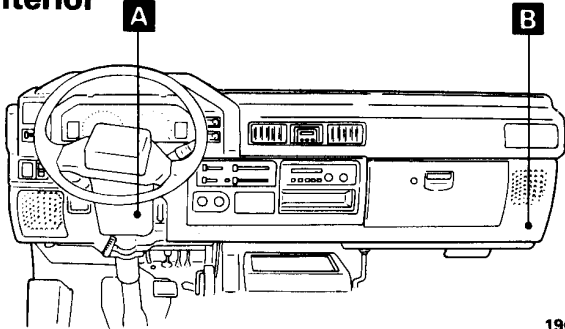

19G0361

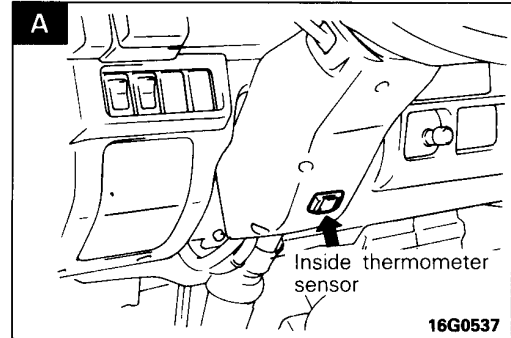

16G0537

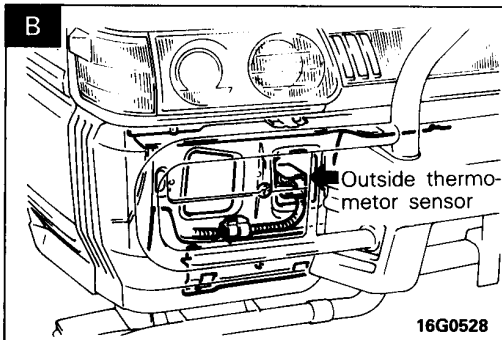

16G0528

4 CIRCUIT DIAGRAM

3 CHARGING CIRCUIT	4-3
8 HEADLAMP CIRCUIT	
8-1 Vehicles without two bulb united type headlamp	4-4
8-2 Vehicles with two bulb united type headlamp	4-6
9 DAYTIME RUNNING LAMP CIRCUIT	
9-1 Vehicles without two bulb united type headlamp	4-8
9-2 Vehicles with two bulb united type headlamp	4-10
10 DIM-DIP LAMP CIRCUIT	4-12
11 HEADLAMP LEVELING CIRCUIT	4-16
12 TAIL LAMP, POSITION LAMP, LICENCE PLATE LAMP CIRCUIT	
12-1 Vehicles without daytime running lamp	4-18
12-2 Vehicles with daytime running lamp	4-20
13 REAR FOG LAMP CIRCUIT	
13-1 Vehicles without daytime running lamp	4-24
13-2 Vehicles with daytime running lamp	4-26
14 ROOM LAMP CIRCUIT	
14-1 Vehicles without crystal-light roof	4-28
14-2 Vehicles with crystal-light roof	4-30
15 ILLUMINATION LAMP CIRCUIT	4-32
20 METER AND GAUGE CIRCUIT	
20-1 Petrol-powered vehicles with carburetor	4-34
20-2 Petrol-powered vehicles with MPI	4-36
20-3 Diesel-powered vehicles	4-38
28 AUDIO CIRCUIT	
28-1 5-door models	4-40
28-2 4-door models	4-41
35 CENTRALIZED JUNCTION	4-42

3 CHARGING CIRCUIT

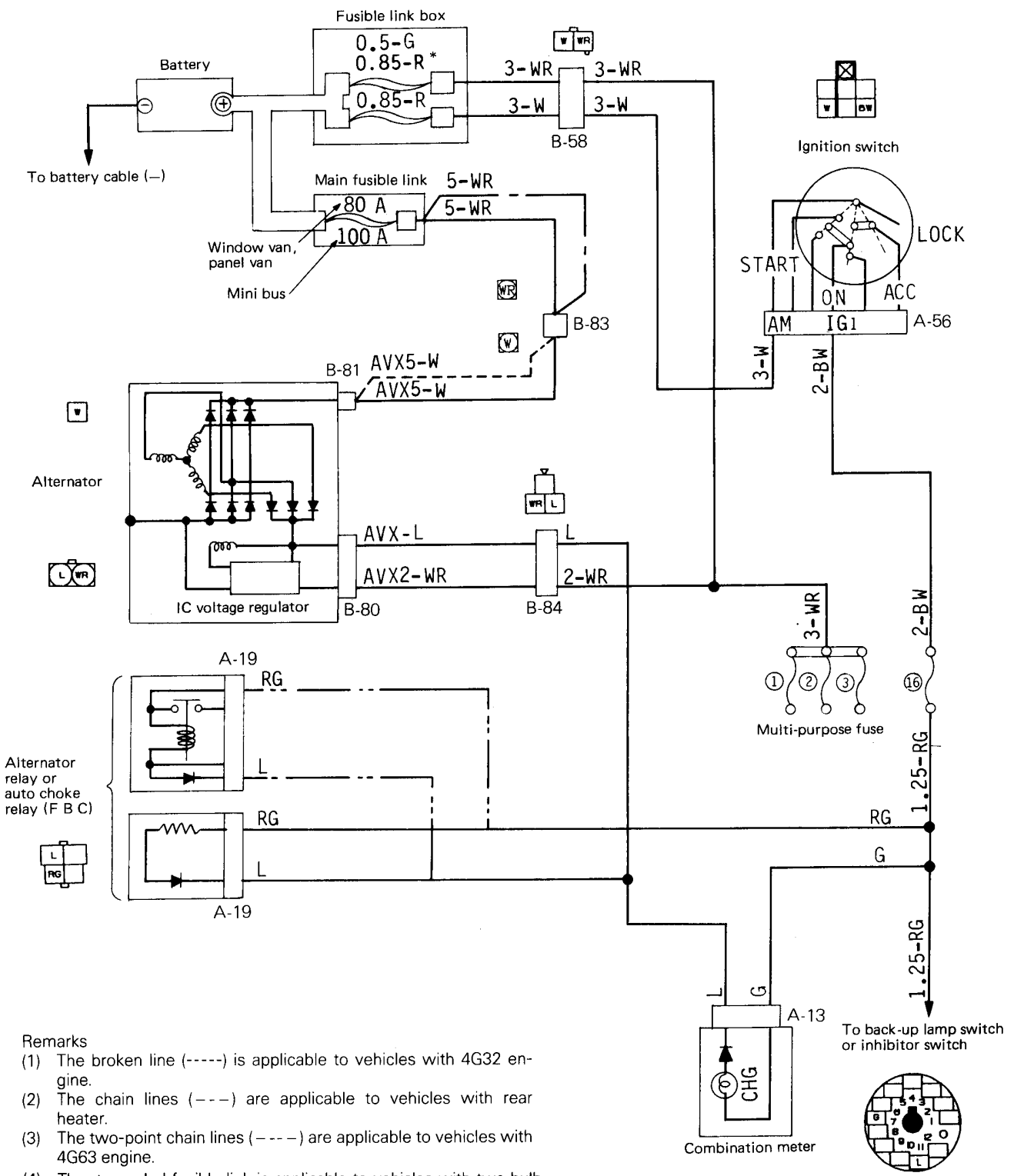

Remarks

- (1) The broken line (-----) is applicable to vehicles with 4G32 engine.
- (2) The chain lines (---) are applicable to vehicles with rear heater.
- (3) The two-point chain lines (----) are applicable to vehicles with 4G63 engine.
- (4) The * symbol fusible link is applicable to vehicles with two bulb united type headlamp.

Wire colour code

B: Black	Br: Brown	G: Green	Gr: Gray	L: Blue	Lg: Light green	
O: Orange	P: Pink	R: Red	Sb: Sky blue	V: Violet	W: White	Y: Yellow

37G0435

8 HEADLAMP CIRCUIT

8-1 Vehicles without two bulb united type headlamp

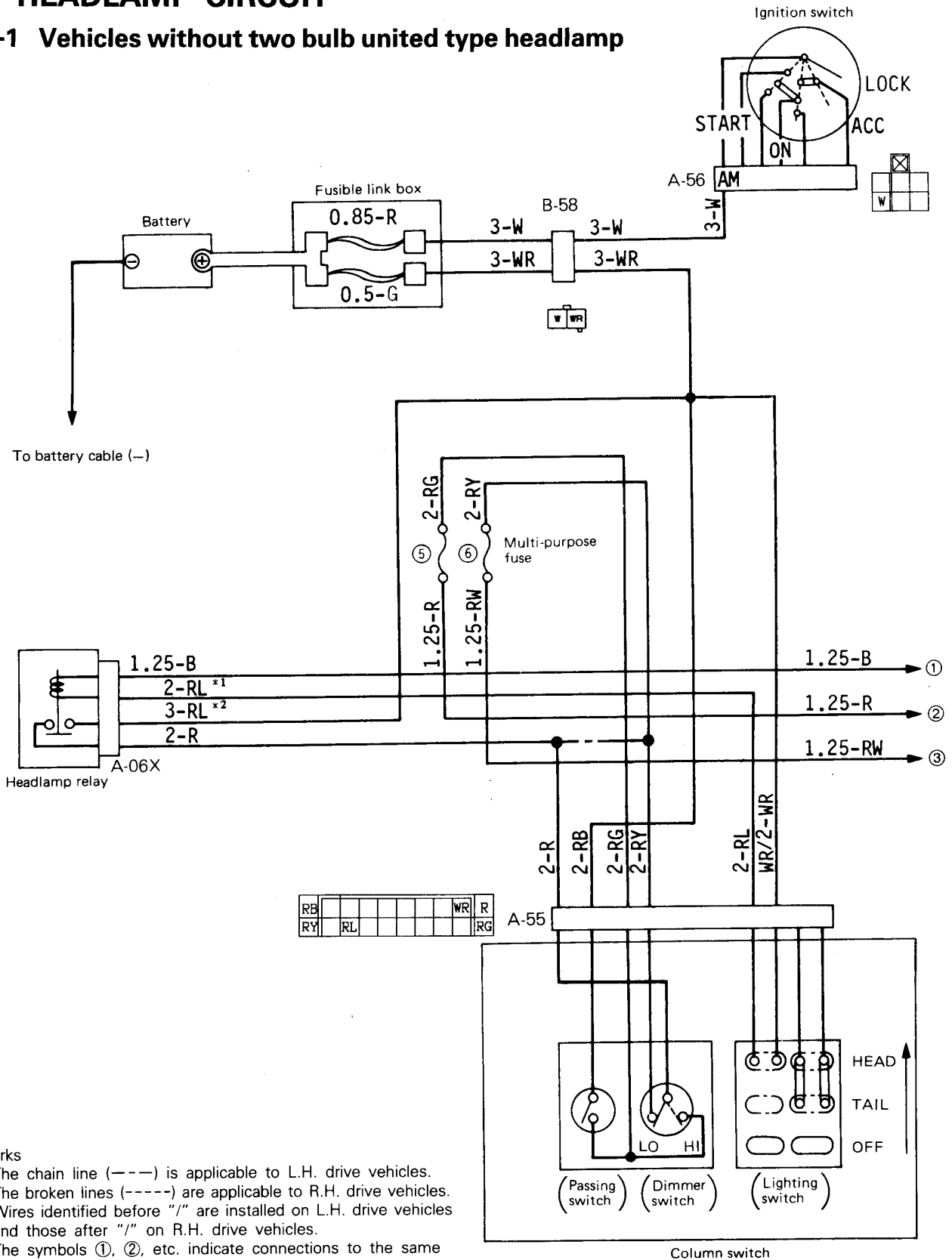

- Remarks
- (1) The chain line (---) is applicable to L.H. drive vehicles.
 - (2) The broken lines (-----) are applicable to R.H. drive vehicles.
 - (3) Wires identified before "/" are installed on L.H. drive vehicles and those after "/" on R.H. drive vehicles.
 - (4) The symbols ①, ②, etc. indicate connections to the same number on the page to the right (or left).
(Thus, ① on the right page is connected to ① on the left page.)

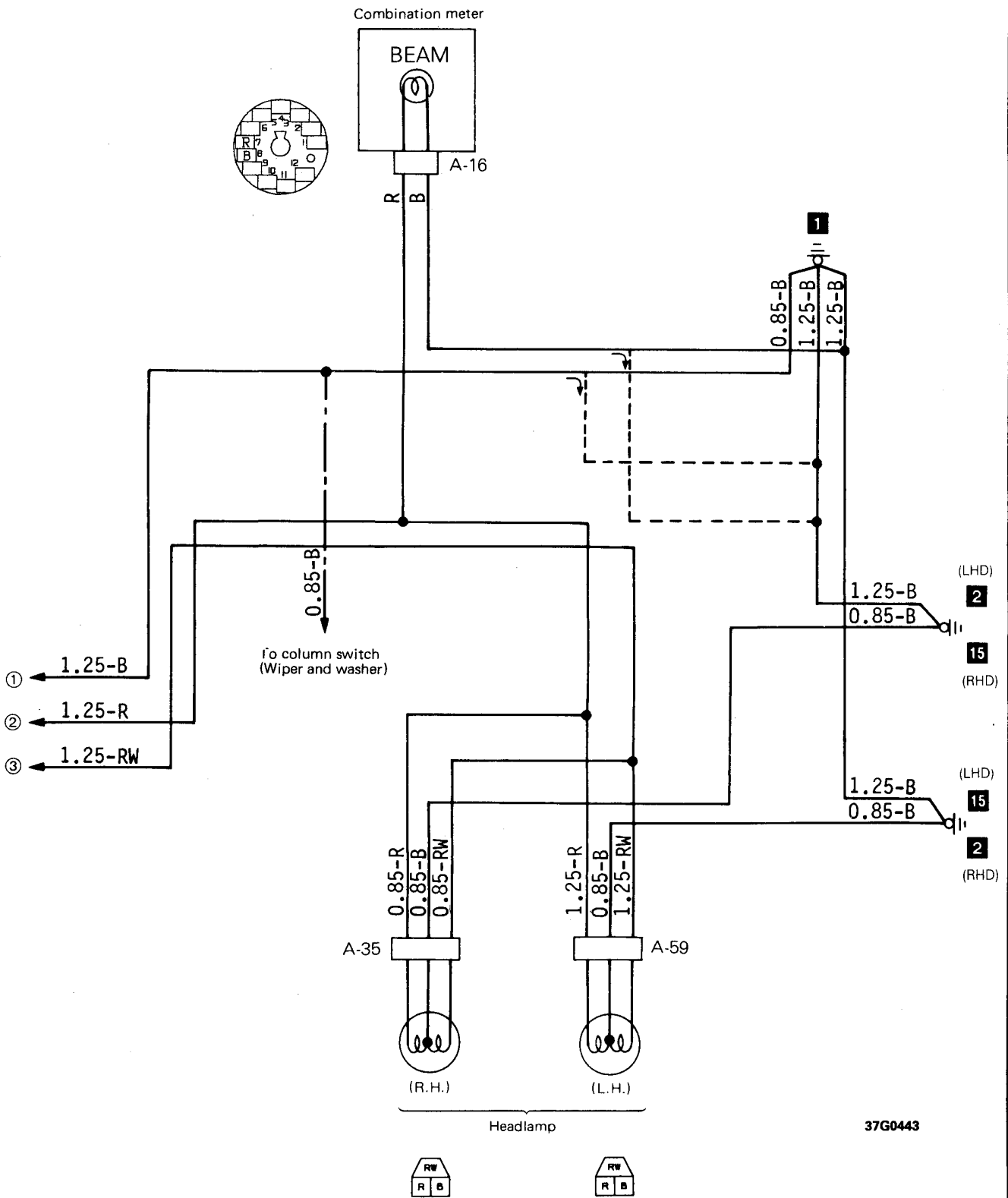

Wire colour code

B: Black	Br: Brown	G: Green	Gr: Gray	L: Blue	Lg: Light green	
O: Orange	P: Pink	R: Red	Sb: Sky blue	V: Violet	W: White	Y: Yellow

8-2 Vehicles with two bulb united type headlamp

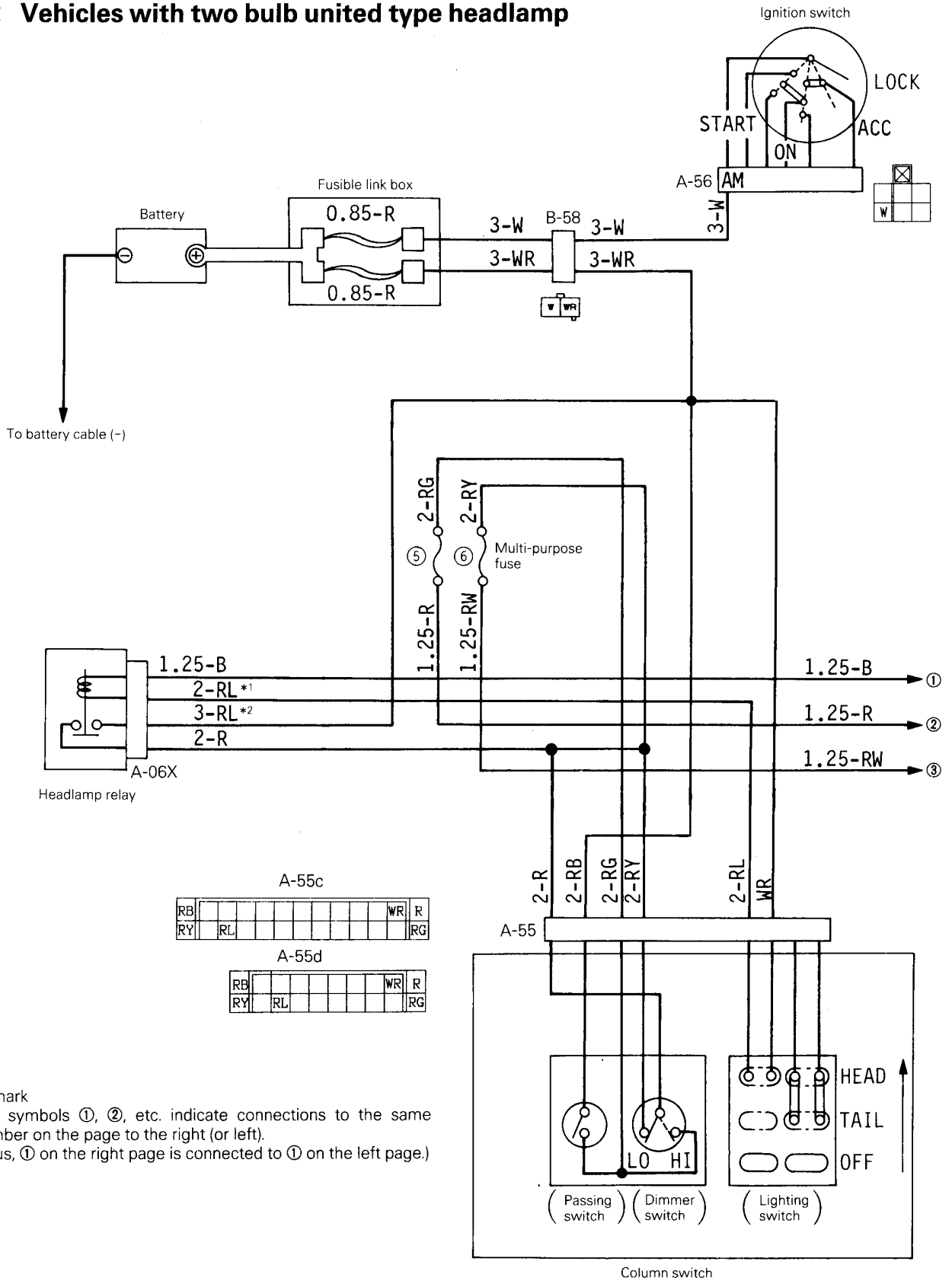

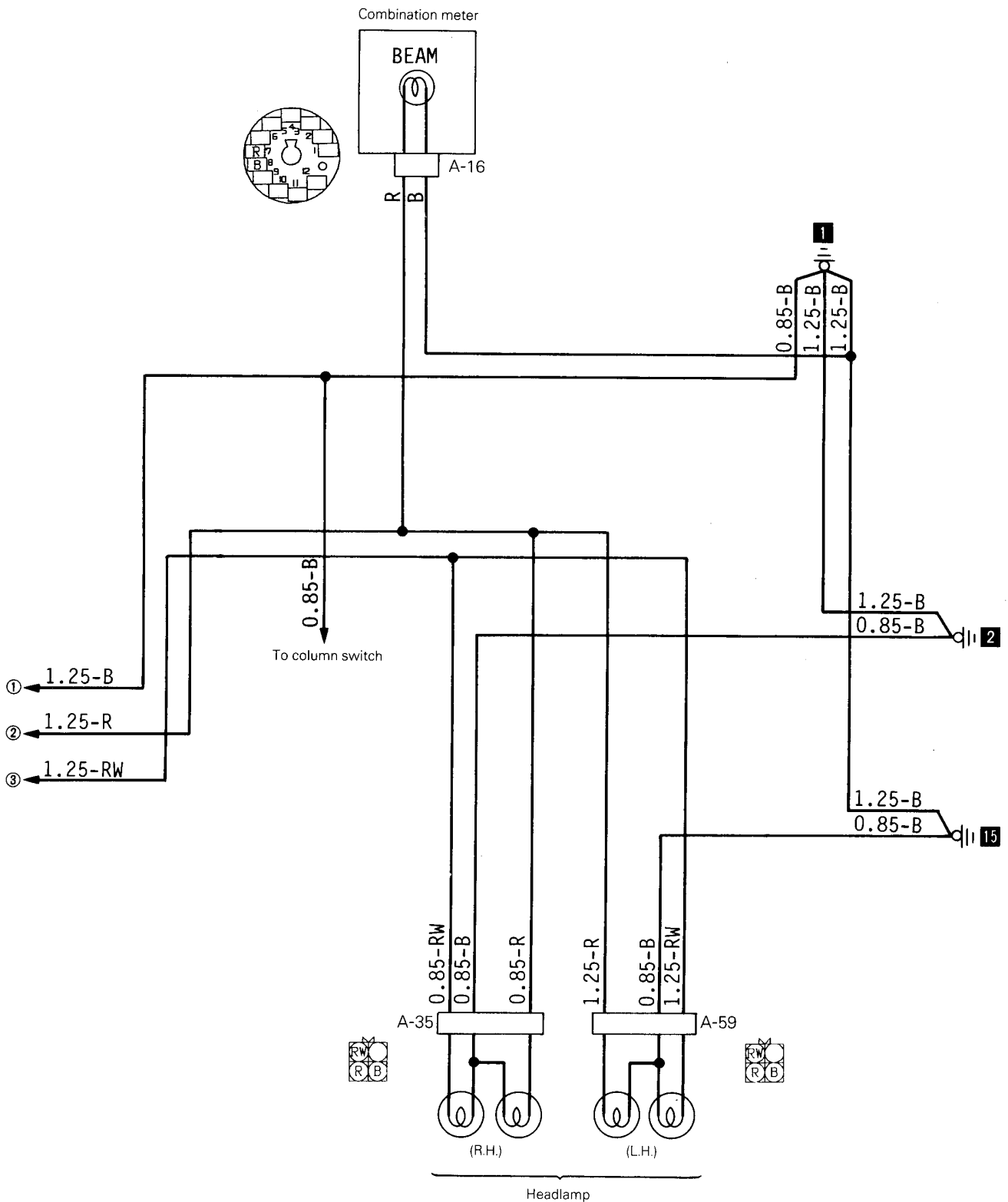

Wire colour code

B: Black	Br: Brown	G: Green	Gr: Gray	L: Blue	Lg: Light green
O: Orange	P: Pink	R: Red	Sb: Sky blue	V: Violet	W: White
				Y: Yellow	

37G0439

9 DAYTIME RUNNING LAMP CIRCUIT

9-1 Vehicles without two bulb united type headlamp

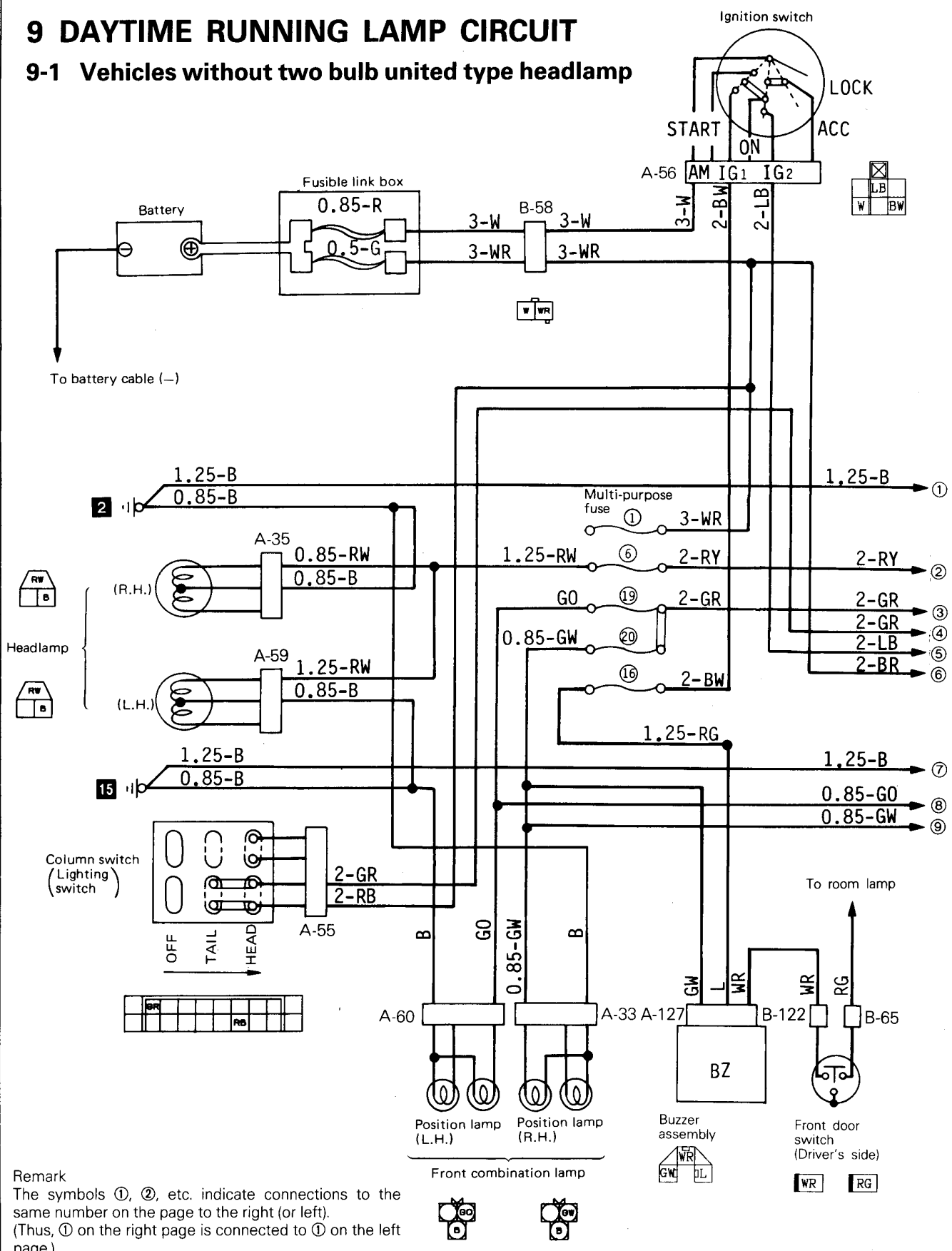

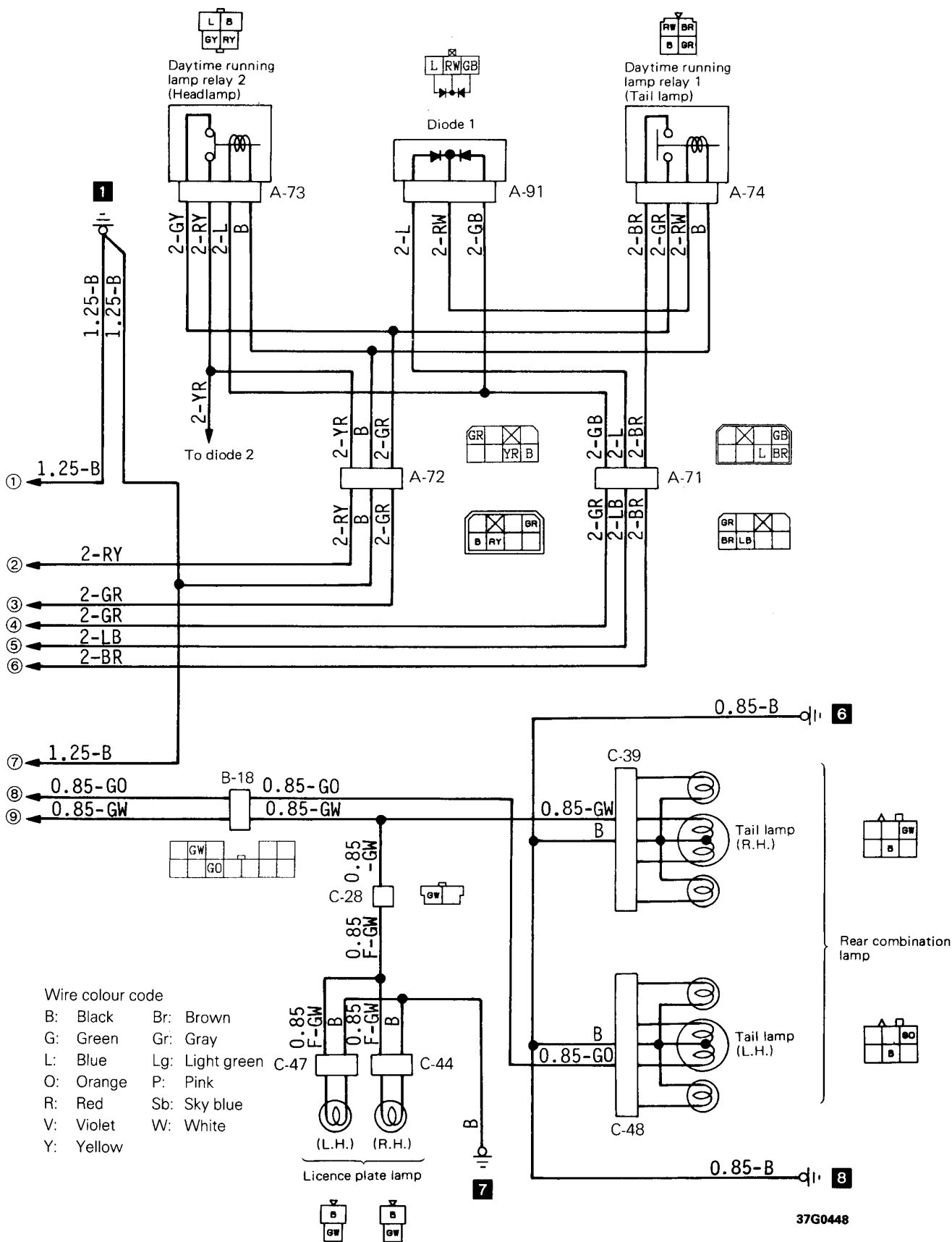

9-2 Vehicles with two bulb united type headlamp

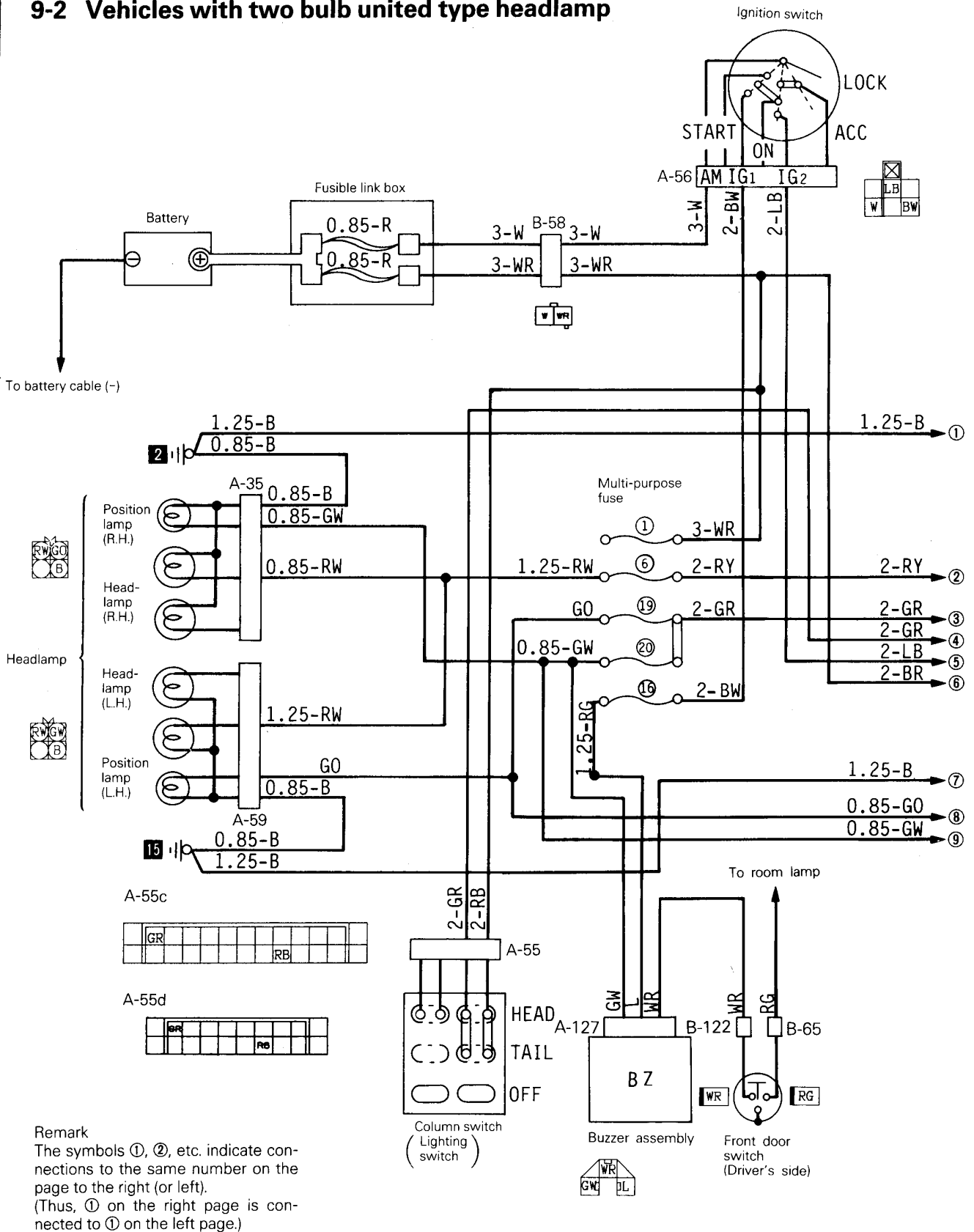

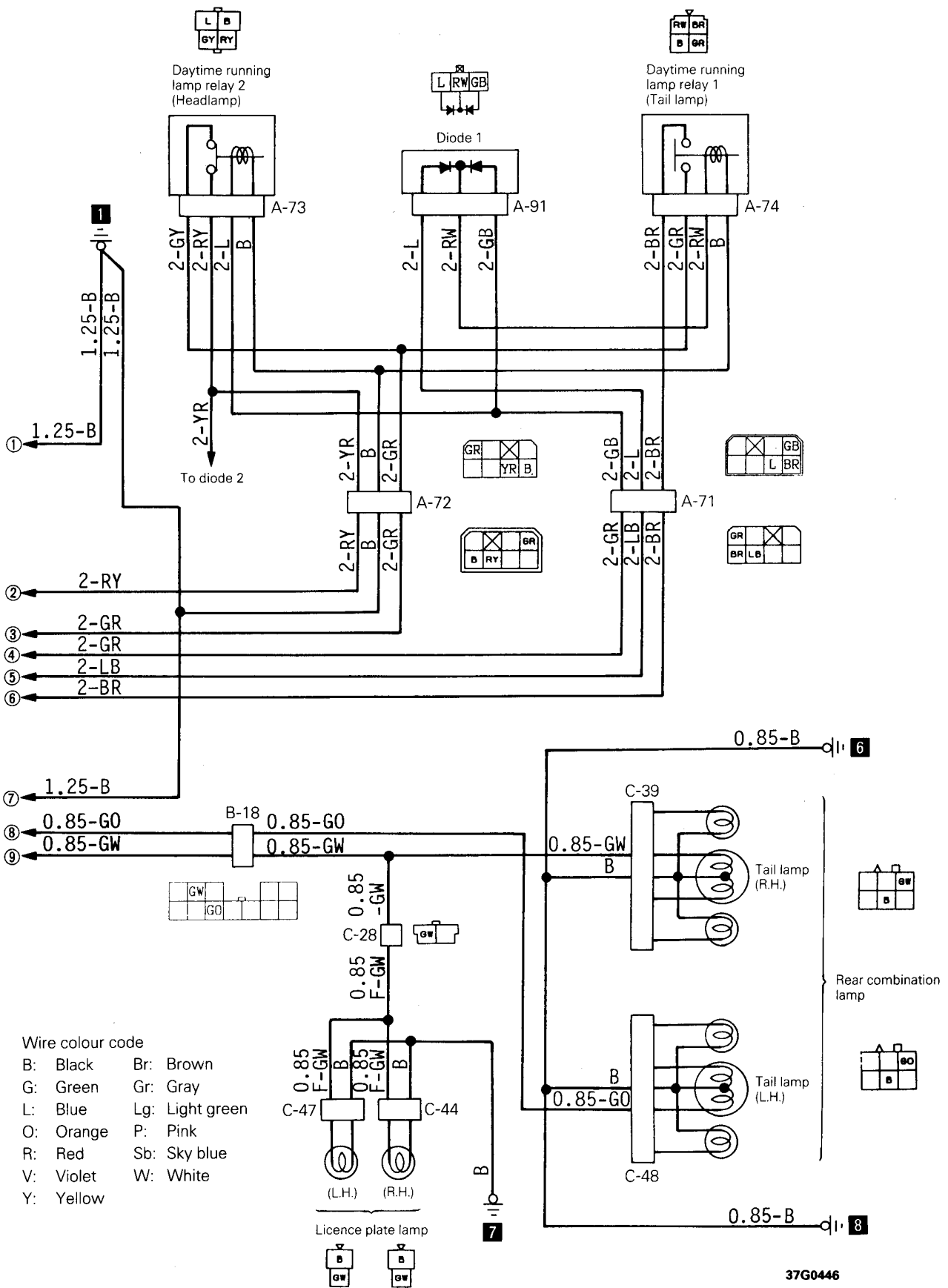

10 DIM-DIP LAMP CIRCUIT

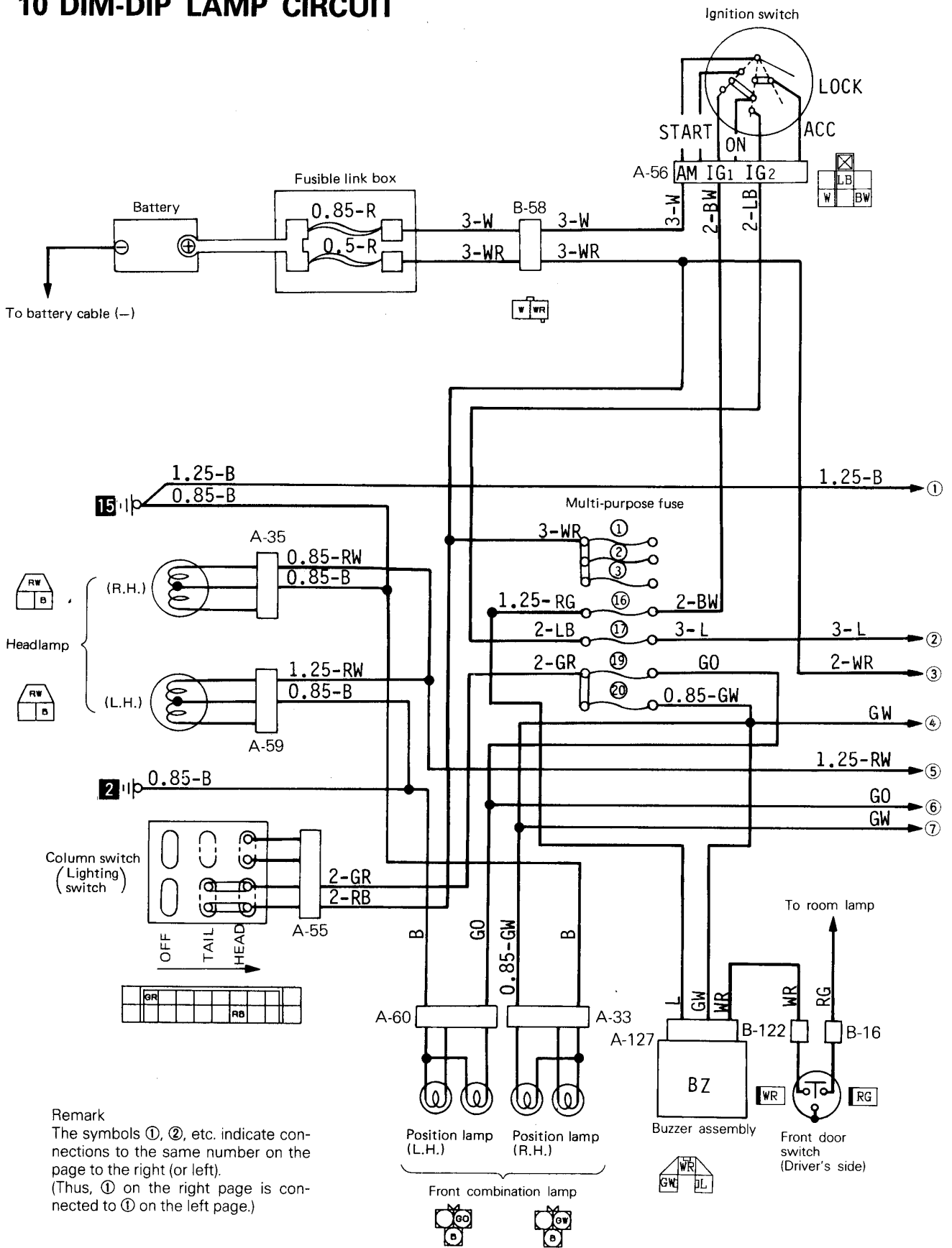

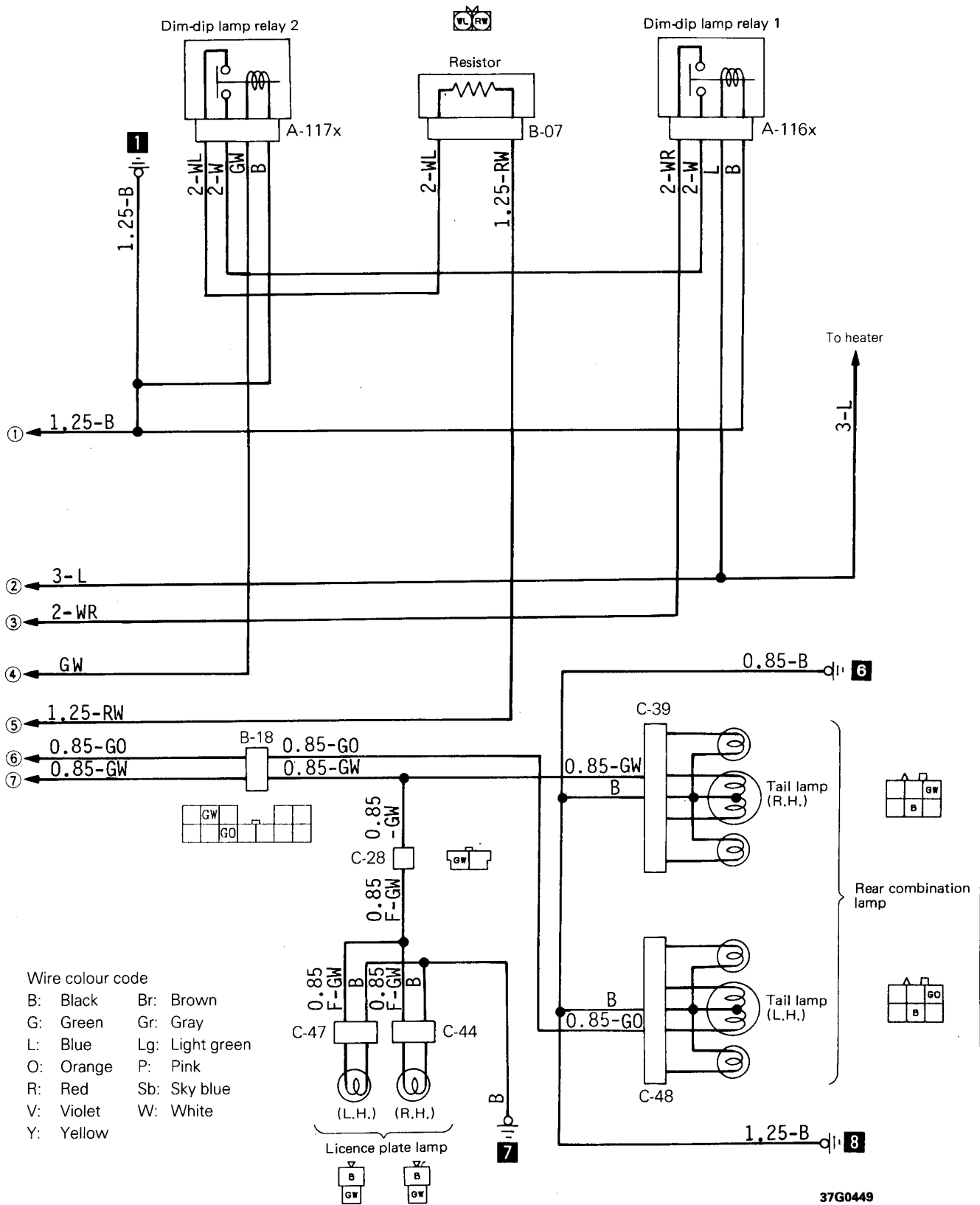

4-14 CIRCUIT DIAGRAM — Headlamp/Daytime Running Lamp/Dim-dip lamp

HEADLAMP CIRCUIT (See P.4-4, 6.)

OPERATION

Headlamp Relay ON Conditions

Ignition switch	Lighting switch	Dimmer/ passing switch	Headlamp relay
—	"HEAD"	—	ON

Remark

- The head lamp circuit has a lighting monitor buzzer system. For operation and troubleshooting hints, refer to TAIL LAMP, POSITION LAMP AND LICENCE PLATE LAMP CIRCUIT (P.4-22).

DAYTIME RUNNING LAMP CIRCUIT (See P.4-8, 10.)

Remark

- The daytime running lamp circuit has a lighting monitor buzzer system. For operation and troubleshooting hints, refer to TAIL LAMP, POSITION LAMP AND LICENCE PLATE LAMP CIRCUIT (P.4-22).

DIM-DIP LAMP CIRCUIT (See P.4-12.)

Remark

- The dim-dip lamp circuit has a lighting monitor buzzer system. For operation and troubleshooting hints, refer to TAIL LAMP, POSITION LAMP AND LICENCE PLATE LAMP CIRCUIT (P.4-22).

NOTES

11 HEADLAMP LEVELING CIRCUIT

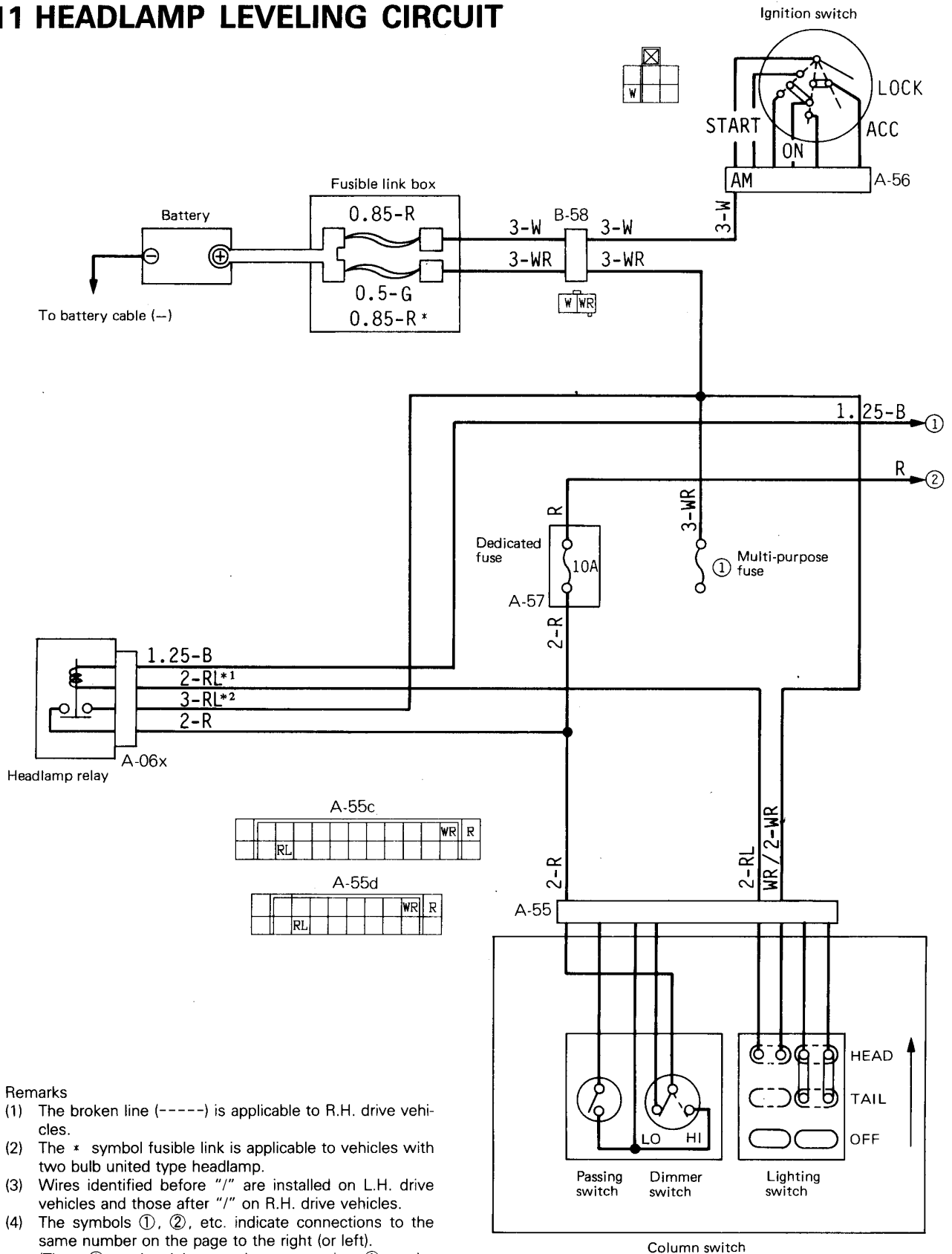

Remarks

- (1) The broken line (-----) is applicable to R.H. drive vehicles.
- (2) The * symbol fusible link is applicable to vehicles with two bulb united type headlamp.
- (3) Wires identified before "/" are installed on L.H. drive vehicles and those after "/" on R.H. drive vehicles.
- (4) The symbols ①, ②, etc. indicate connections to the same number on the page to the right (or left). (Thus, ① on the right page is connected to ① on the left page.)

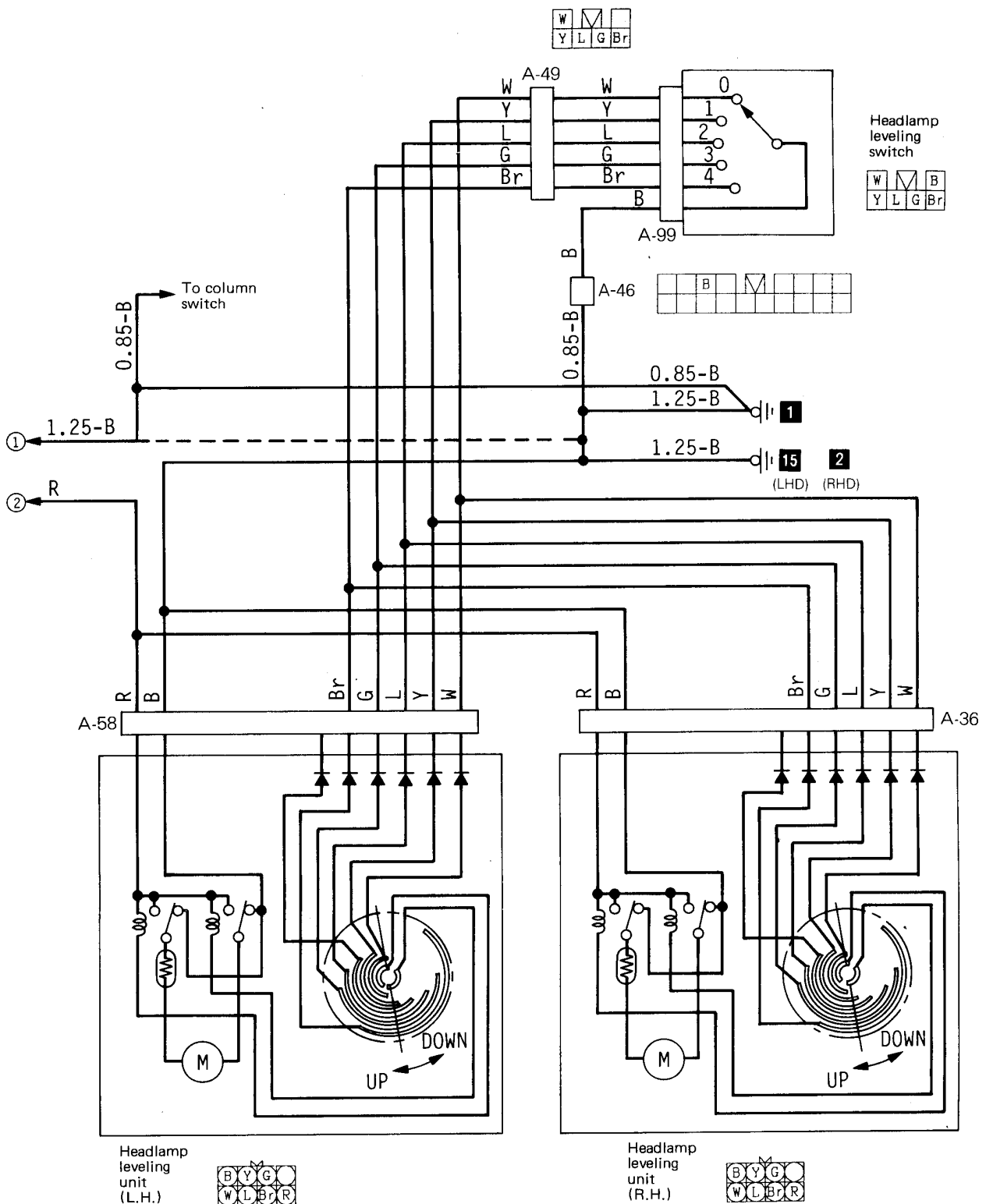

Wire colour code

B: Black	Br: Brown	G: Green	Gr: Gray	L: Blue	Lg: Light green	
O: Orange	P: Pink	R: Red	Sb: Sky blue	V: Violet	W: White	Y: Yellow

12 TAIL LAMP, POSITION LAMP AND LICENCE PLATE LAMP CIRCUIT

12-1 Vehicles without daytime running lamp

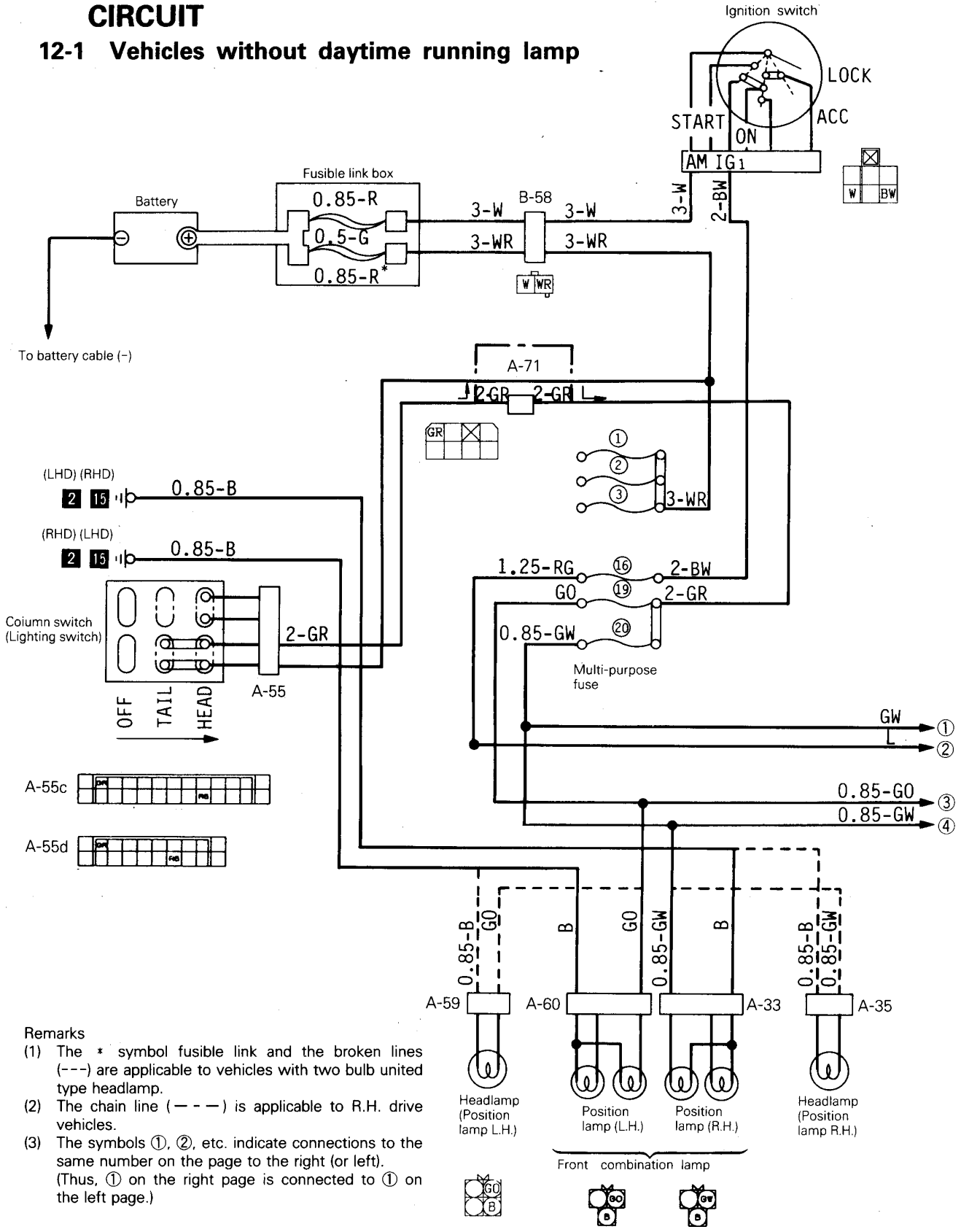

Remarks

- (1) The * symbol fusible link and the broken lines (---) are applicable to vehicles with two bulb united type headlamp.
- (2) The chain line (---) is applicable to R.H. drive vehicles.
- (3) The symbols ①, ②, etc. indicate connections to the same number on the page to the right (or left). (Thus, ① on the right page is connected to ① on the left page.)

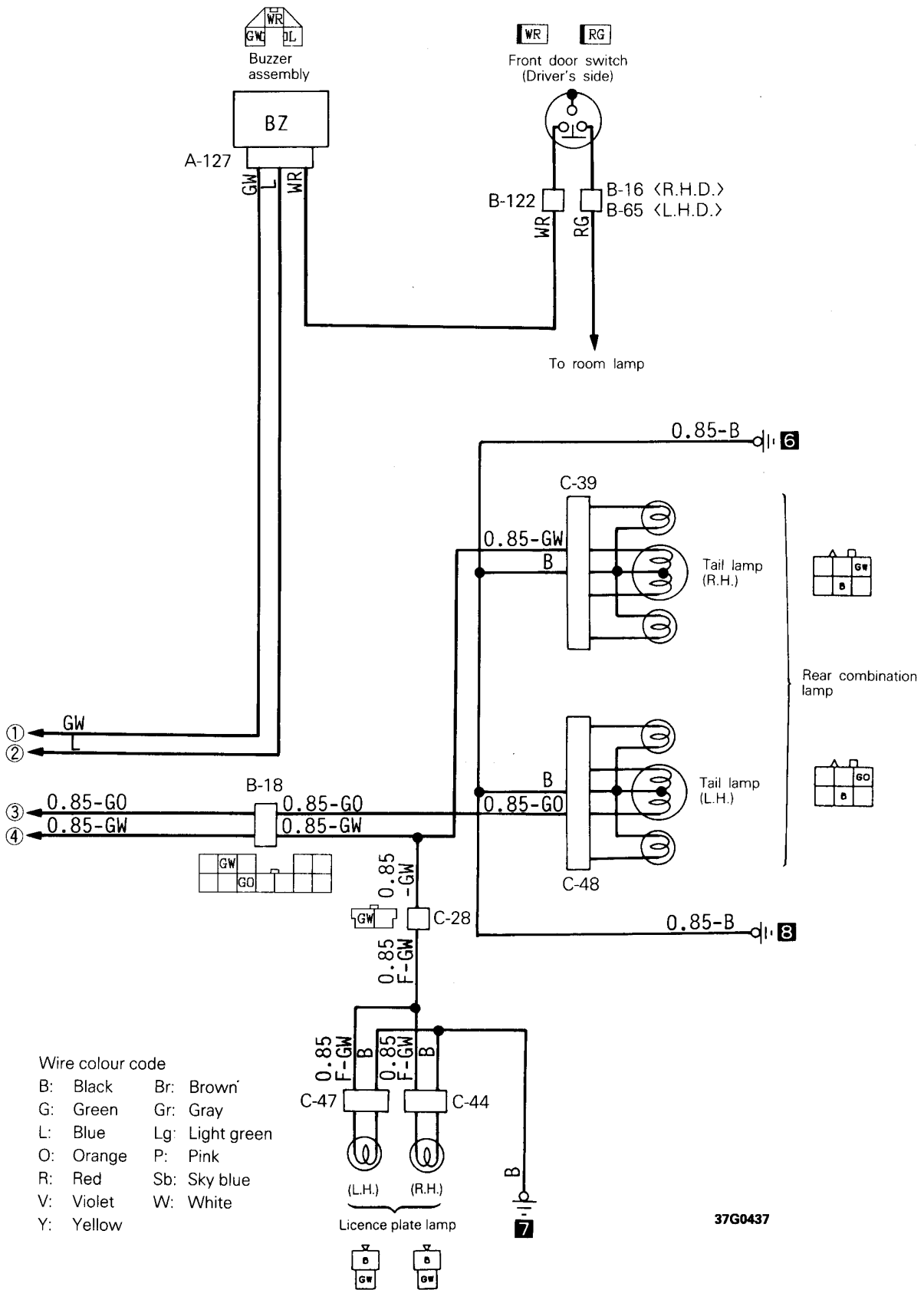

12-2 Vehicles with daytime running lamp

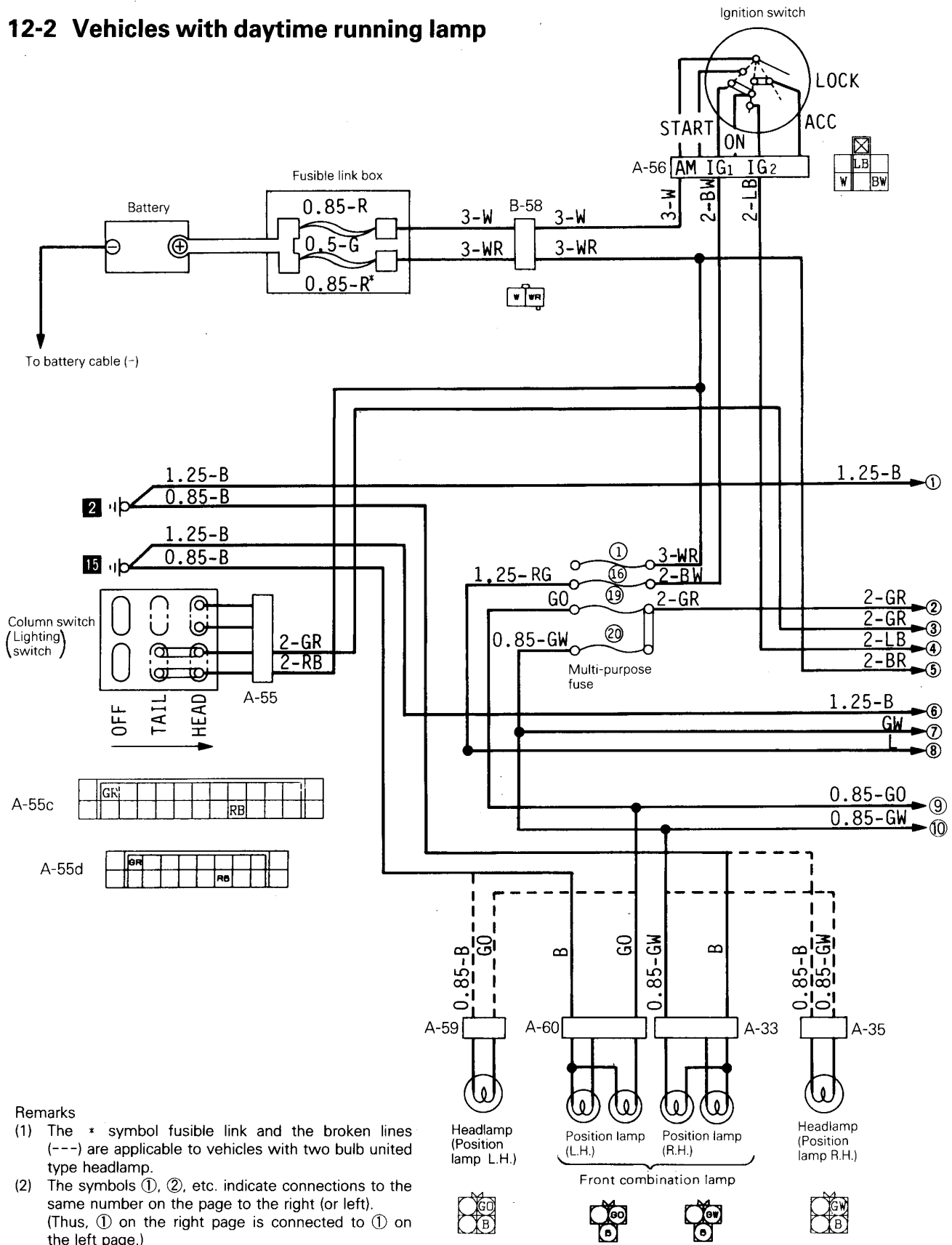

Remarks

- (1) The * symbol fusible link and the broken lines (---) are applicable to vehicles with two bulb united type headlamp.
- (2) The symbols ①, ②, etc. indicate connections to the same number on the page to the right (or left). (Thus, ① on the right page is connected to ① on the left page.)

CIRCUIT DIAGRAMS – Tail Lamp, Position Lamp and Licence Plate Lamp 4-21

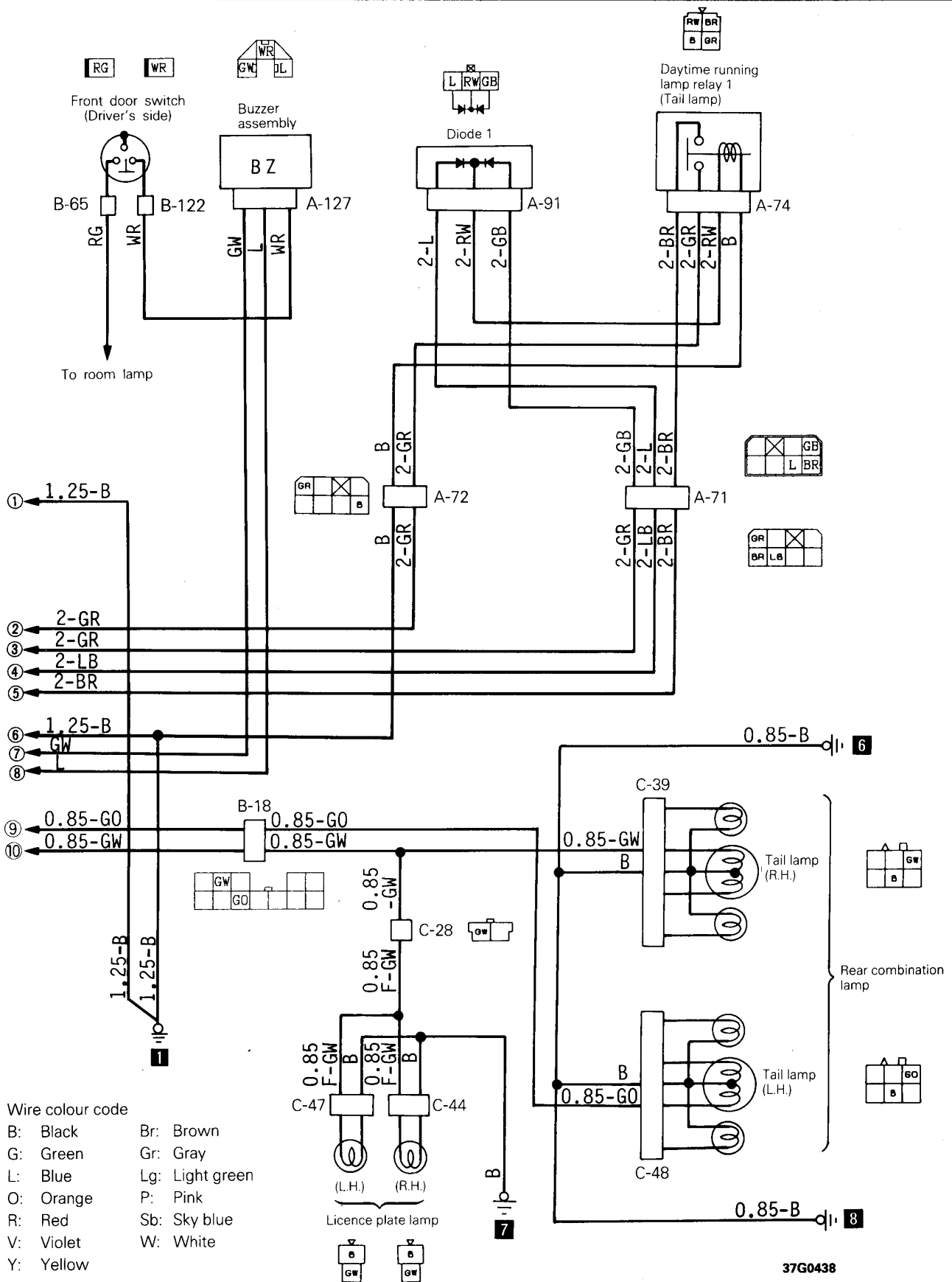

4-22 CIRCUIT DIAGRAMS — Tail Lamp, Position Lamp and Licence Plate Lamp

TAIL LAMP, POSITION LAMP AND LICENCE PLATE LAMP CIRCUIT (See P.4-18, 20.)

OPERATION

<Lighting monitor buzzer operation>

- When the lighting switch is set to the TAIL or HEAD position with the ignition switch is in the "OFF" position, if the driver's side door is opened and the front door switch turns "ON", the buzzer sounds to indicate that the lamps are not switched off.

TROUBLESHOOTING HINTS

1. Lighting monitor buzzer doesn't sound.
 - (1) But the tail lamp do illuminate.
 - Check the buzzer assembly.
 - Check the front door switch (driver's side)
 - Check multi-purpose fuse No. ⑩.
 - (2) The tail lamps also don't illuminate.
 - Check multi-purpose fuse No. ⑳.

REAR FOG LAMP CIRCUIT <Vehicles without daytime running lamp> (See P.4-24.)**OPERATION**

- When the lighting switch is in the HEAD position, current flows through multi-purpose fuse No. ⑩ to rear fog lamp switch.
- When the rear fog lamp switch is pushed ON in this condition, the rear fog lamp comes on.

REAR FOG LAMP CIRCUIT <Vehicles with daytime running lamp> (See P.4-26.)**OPERATION**

Rear Fog Lamp Relay ON Conditions

Ignition switch	Lighting switch	Rear fog lamp relay
—	"HEAD"	ON

- Turning the lighting switch to the "HEAD" position causes the rear fog lamp relay to be energized.
- When the rear fog lamp switch is turned ON in this condition, the rear fog lamp comes on.

13 REAR FOG LAMP CIRCUIT

13-1 Vehicles without daytime running lamp

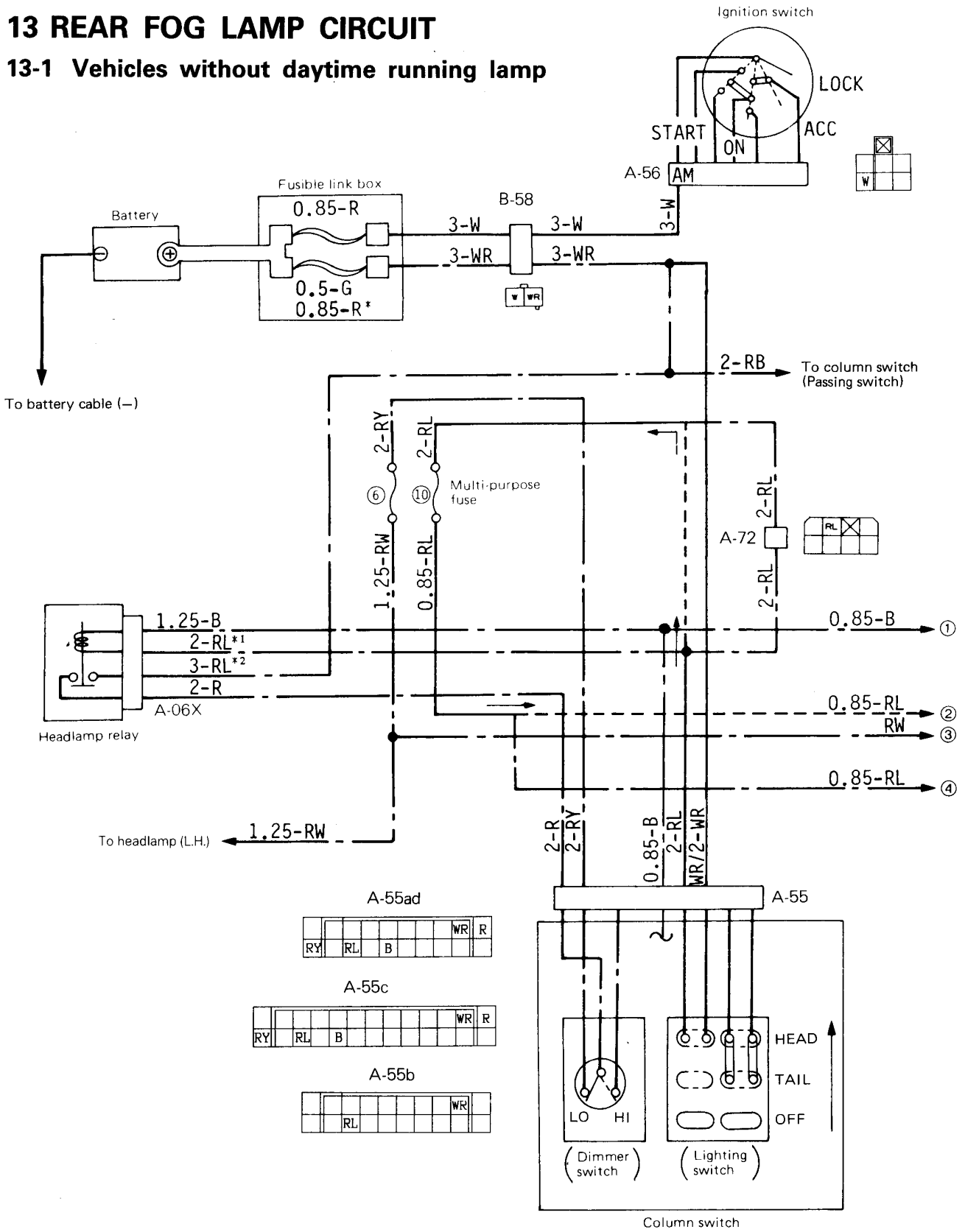

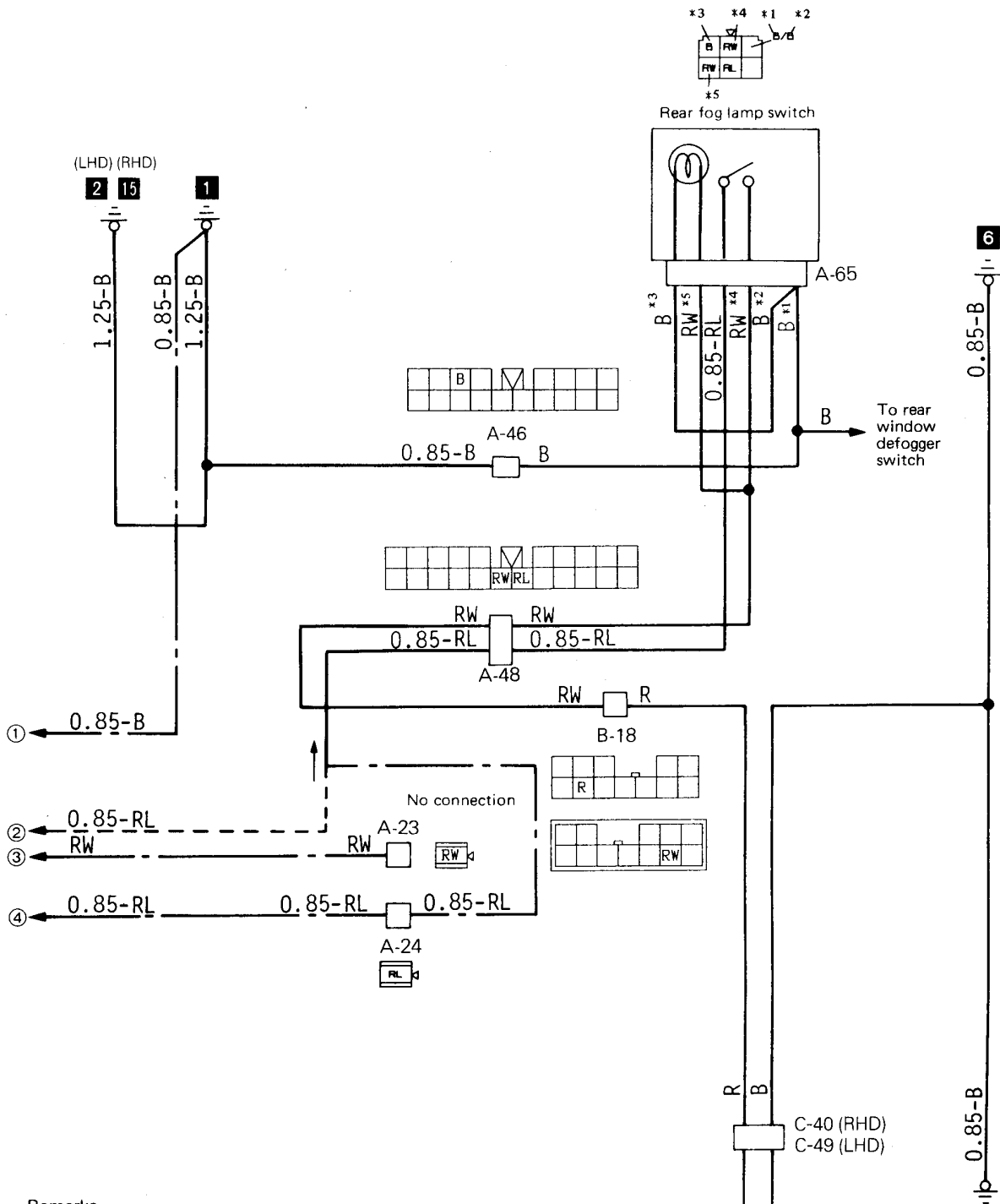

Remarks

- (1) The * symbol fusible link is applicable to vehicles with two bulb united type headlamp.
- (2) The broken lines (-----) are applicable to R.H. drive vehicles.
- (3) The chain lines (---) are applicable to L.H. drive vehicles.
- (4) Wires identified before "/" are installed on L.H. drive vehicles and those after "/" on R.H. drive vehicles.
- (5) The symbols ①, ②, etc. indicate connections to the same number on the page to the right (or left).
(Thus, ① on the right page is connected to ① on the left page.)

Wire colour code

B: Black	Br: Brown	G: Green	Gr: Gray	L: Blue	Lg: Light green	
O: Orange	P: Pink	R: Red	Sb: Sky blue	V: Violet	W: White	Y: Yellow

37G0442

13-2 Vehicles with daytime running lamp

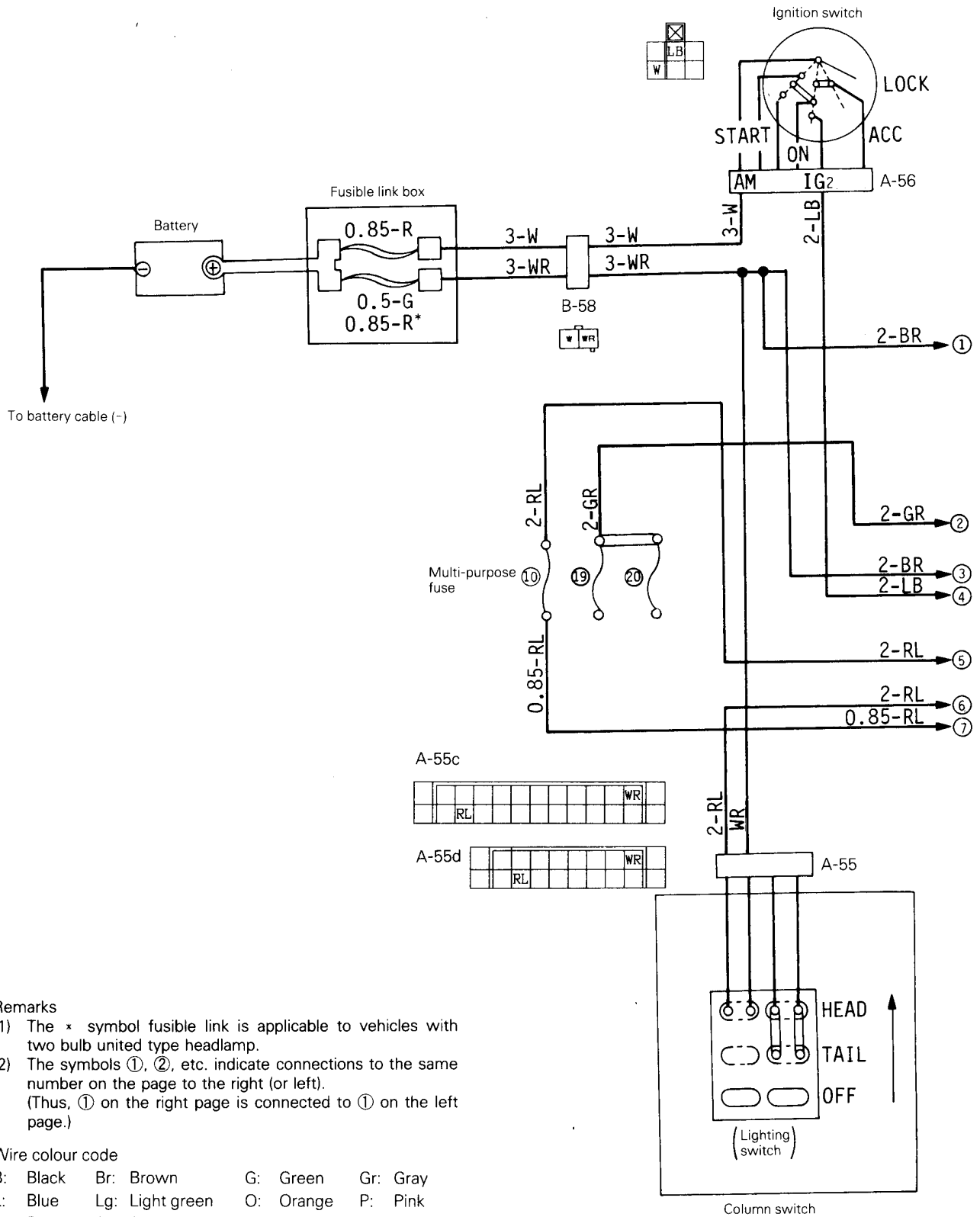

Remarks

- (1) The * symbol fusible link is applicable to vehicles with two bulb united type headlamp.
- (2) The symbols ①, ②, etc. indicate connections to the same number on the page to the right (or left). (Thus, ① on the right page is connected to ① on the left page.)

Wire colour code

B: Black	Br: Brown	G: Green	Gr: Gray
L: Blue	Lg: Light green	O: Orange	P: Pink
R: Red	Sb: Sky blue	V: Violet	W: White
Y: Yellow			

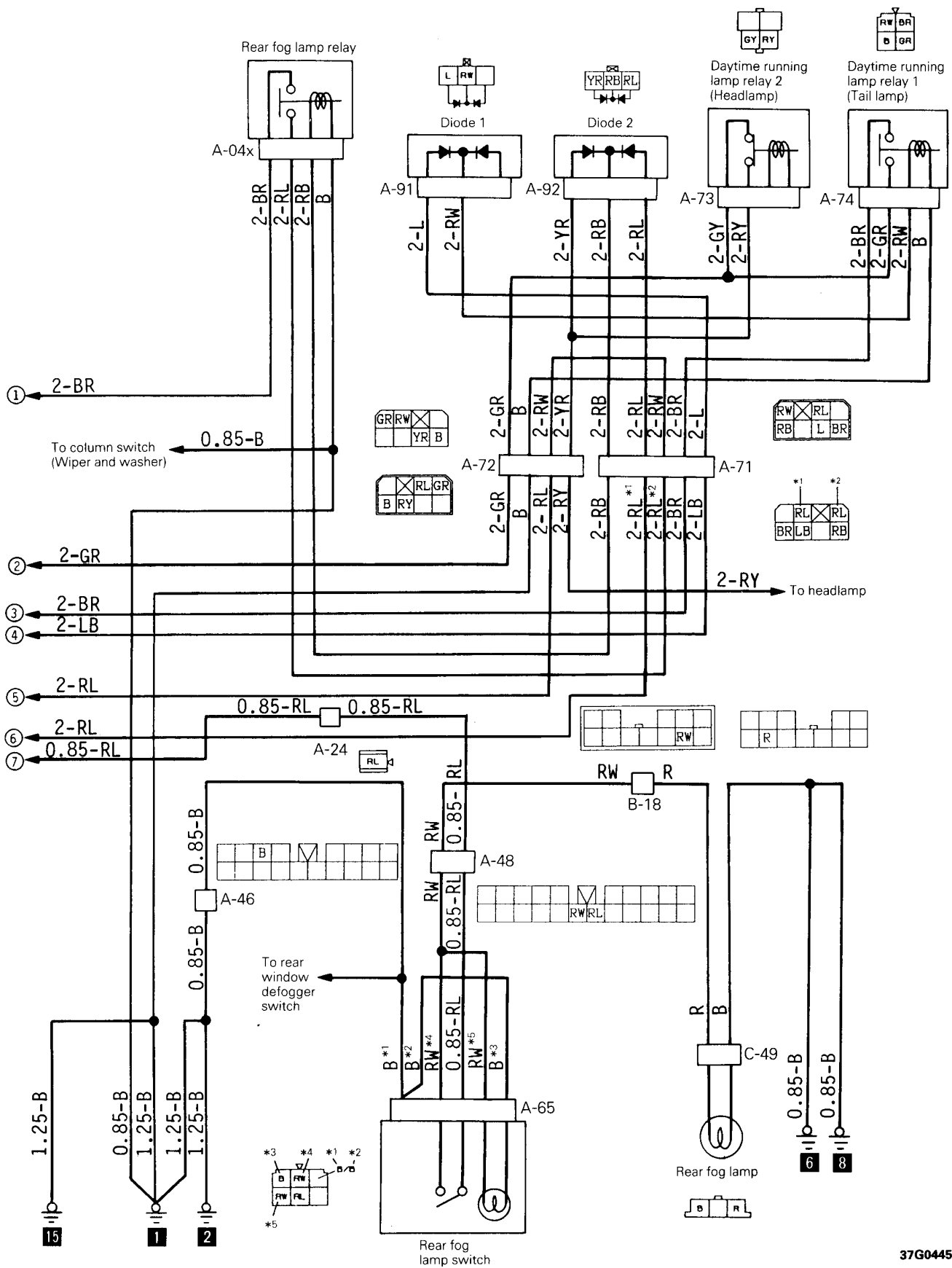

14 ROOM LAMP CIRCUIT

14-1 Vehicles without crystal-light roof

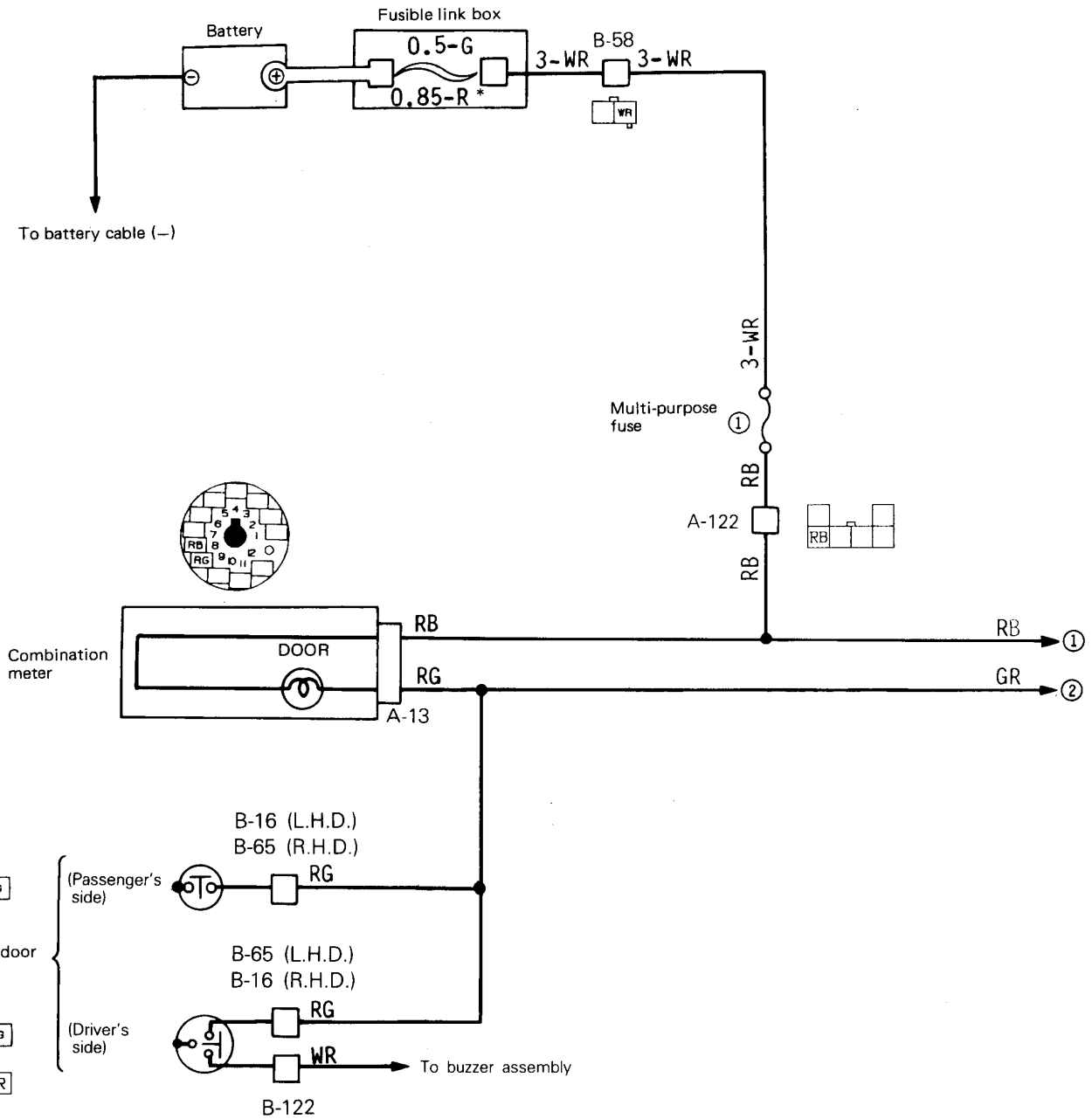

Remarks

- (1) The * symbol fusible link is applicable to vehicles with two bulb united type headlamp.
- (2) The chain lines (---) are applicable to vehicles with rear room lamp and spot lamp.
- (3) The broken lines (-----) are applicable to vehicles with rear speaker.
- (4) The symbols ①, ②, etc. indicate connections to the same number on the page to the right (or left).
(Thus, ① on the right page is connected to ① on the left page.)

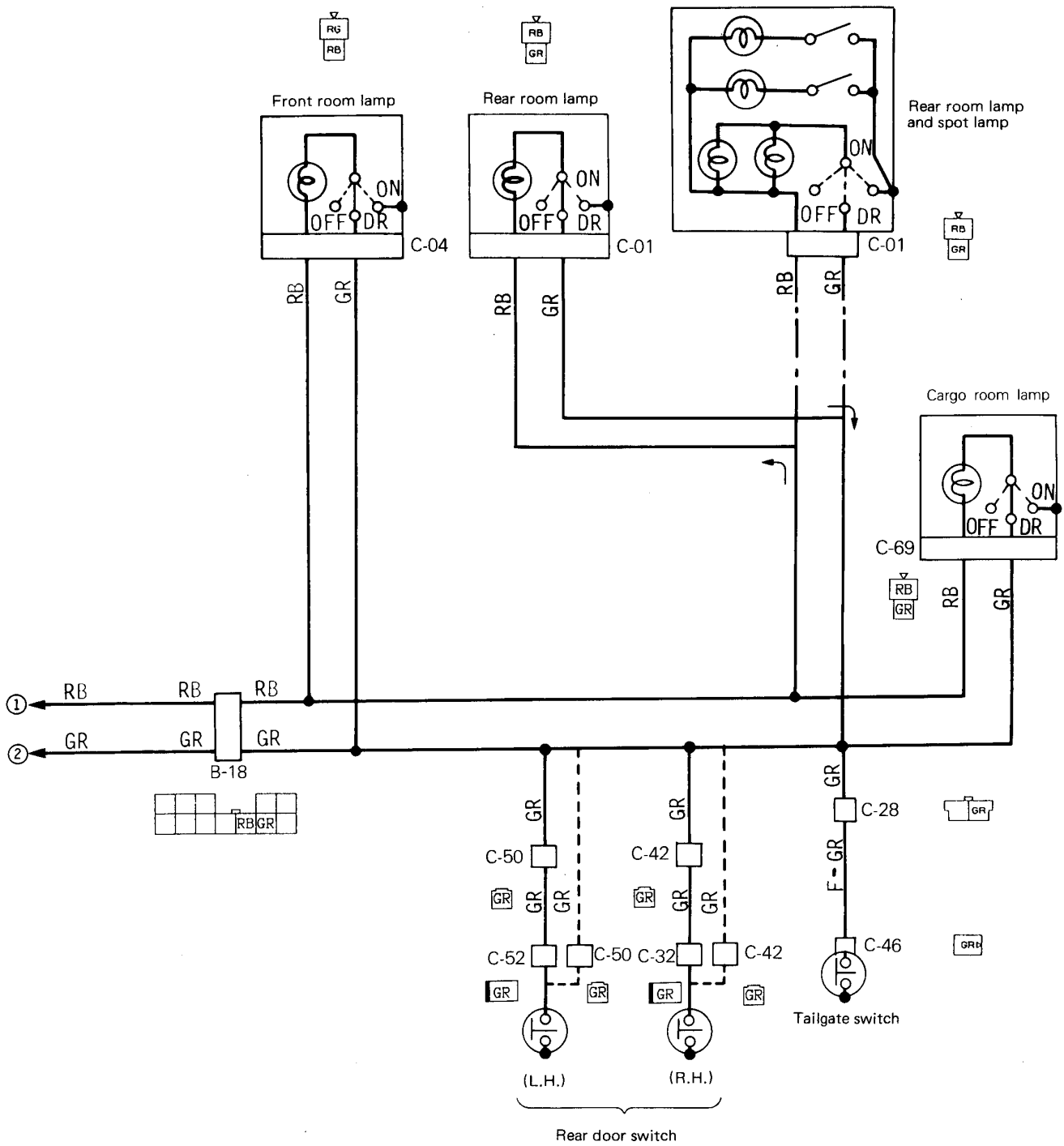

Wire colour code

- | | | | | | | |
|-----------|-----------|----------|--------------|-----------|-----------------|-----------|
| B: Black | Br: Brown | G: Green | Gr: Gray | L: Blue | Lg: Light green | |
| O: Orange | P: Pink | R: Red | Sb: Sky blue | V: Violet | W: White | Y: Yellow |

37G0447

14-2 Vehicles with crystal-light roof

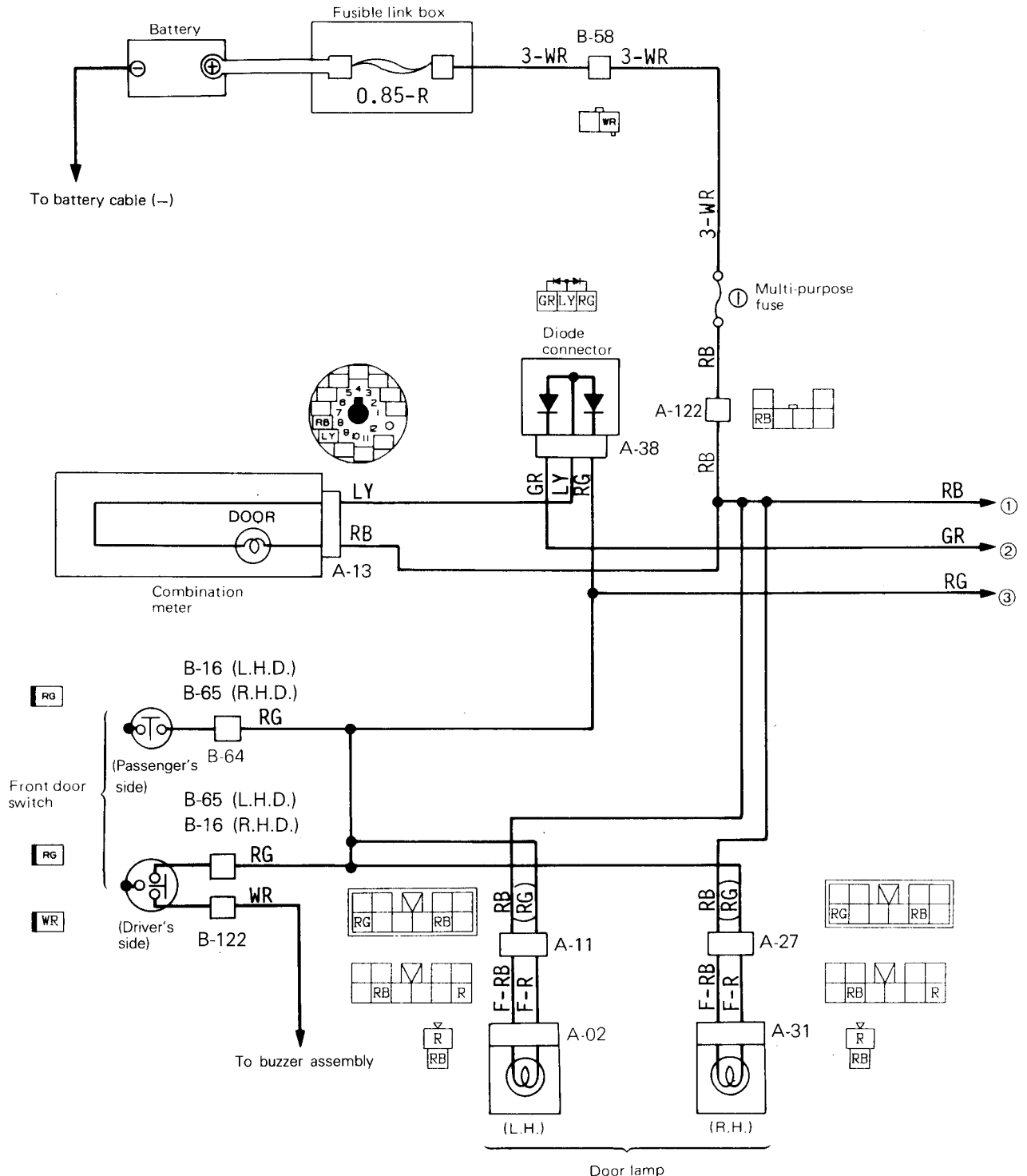

Remarks

- (1) The broken line (----) is applicable to vehicles without rear speaker.
- (2) The symbols ①, ②, etc. indicate connections to the same number on the page to the right (or left).
(Thus, ① on the right page is connected to ① on the left page.)

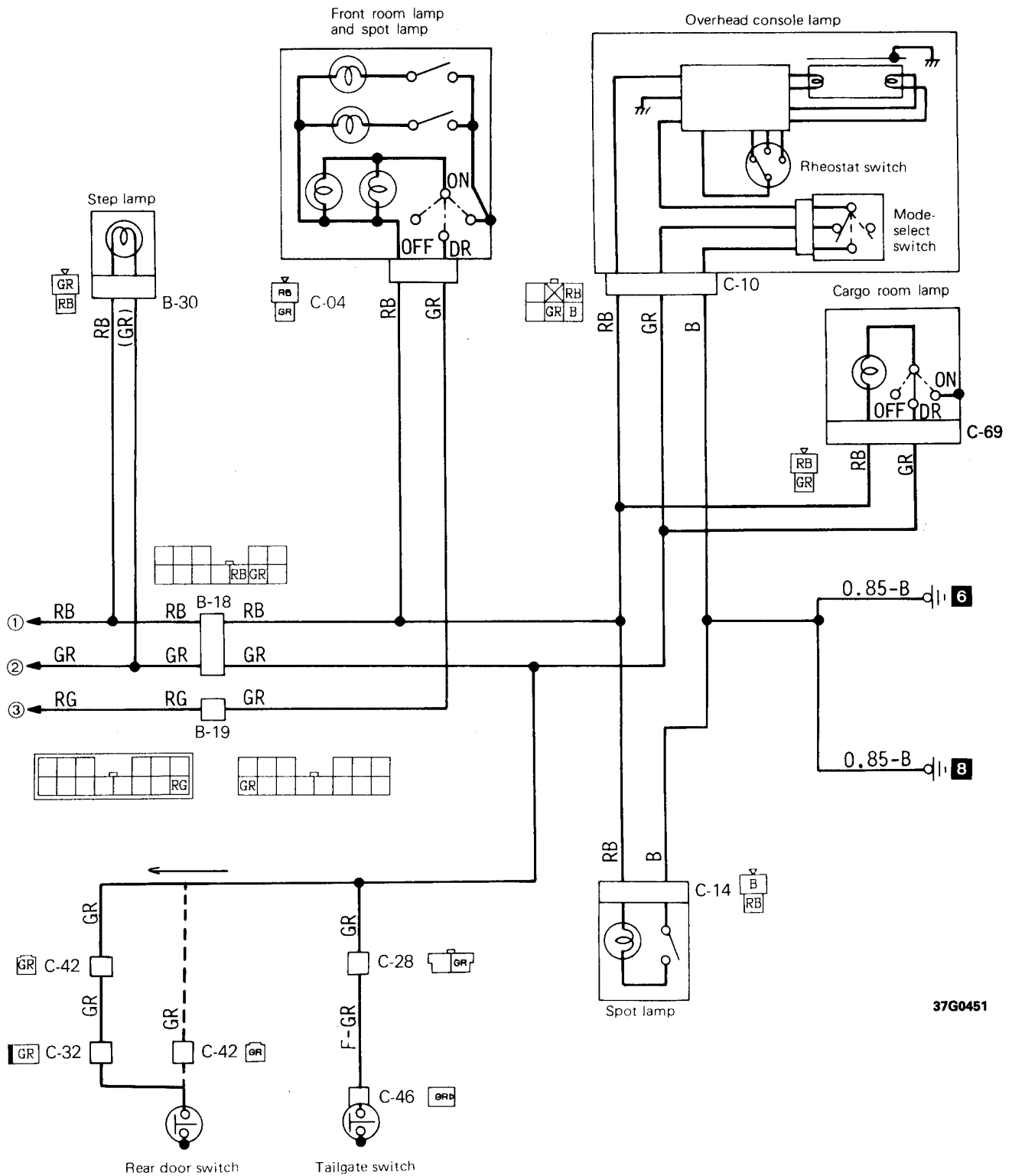

37G0451

Wire colour code

B: Black	Br: Brown	G: Green	Gr: Gray	L: Blue	Lg: Light green
O: Orange	P: Pink	R: Red	Sb: Sky blue	V: Violet	W: White
					Y: Yellow

15 ILLUMINATION LAMP CIRCUIT

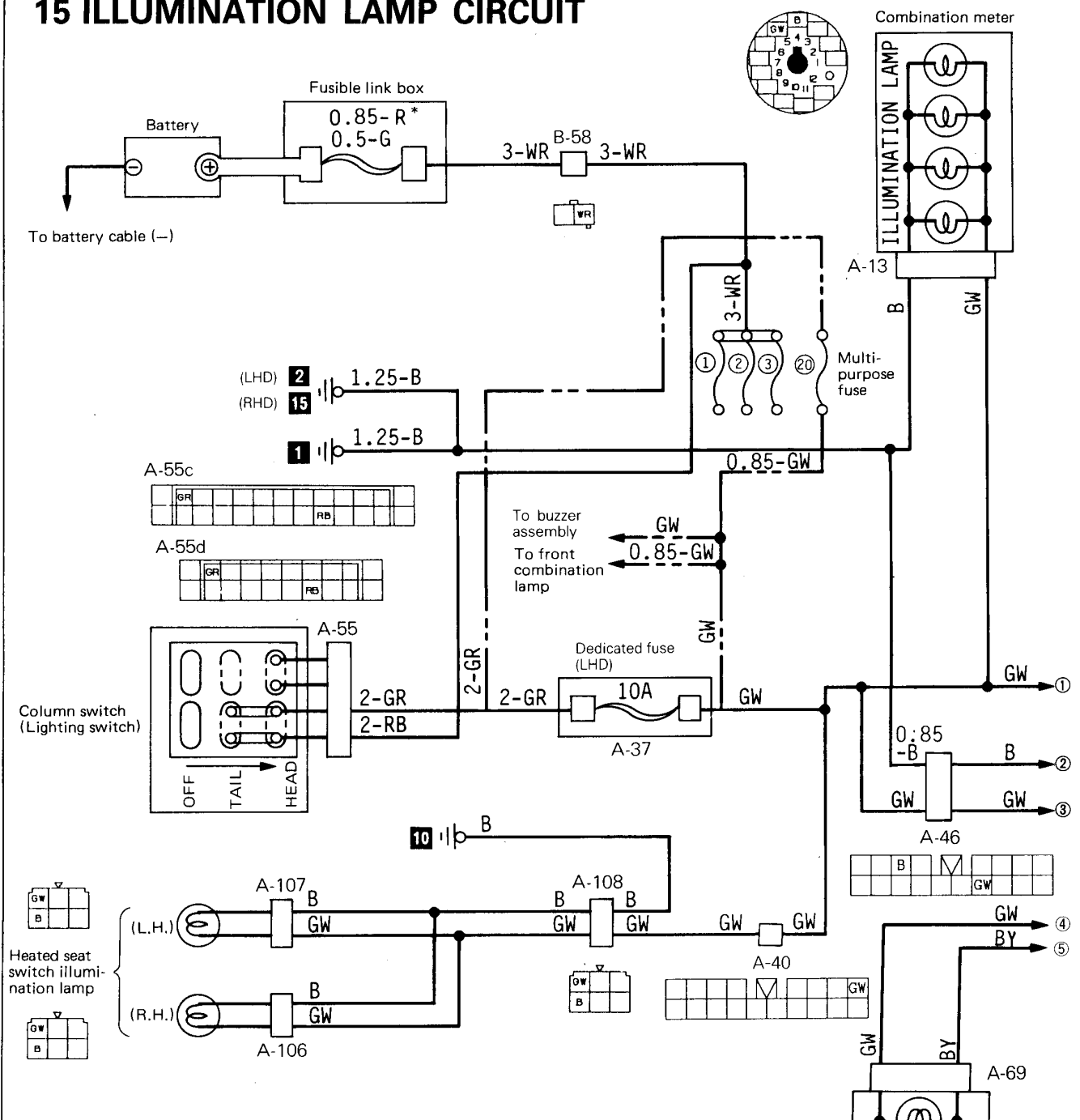

Remarks

- (1) The broken line (-----) is applicable to 4-door models.
- (2) The chain lines (----) is applicable to 5-door models.
- (3) The two-point chain lines (-----) are applicable to R.H. drive vehicles.
- (4) The three-point chain lines (-----) are applicable to vehicles with inclinometer.
- (5) The four-point chain line (-----) is applicable to 4WD vehicles with three-meter unit.
- (6) The * symbol fusible link is applicable to vehicles with two bulb united type headlamp.
- (7) The symbols ①, ②, etc. indicate connections to the same number on the page to the right (or left). (Thus, ① on the right page is connected to ① on the left page.)

Wire colour code

B: Black	Br: Brown	G: Green	Gr: Gray	L: Blue	Lg: Light green	
O: Orange	P: Pink	R: Red	Sb: Sky blue	V: Violet	W: White	Y: Yellow

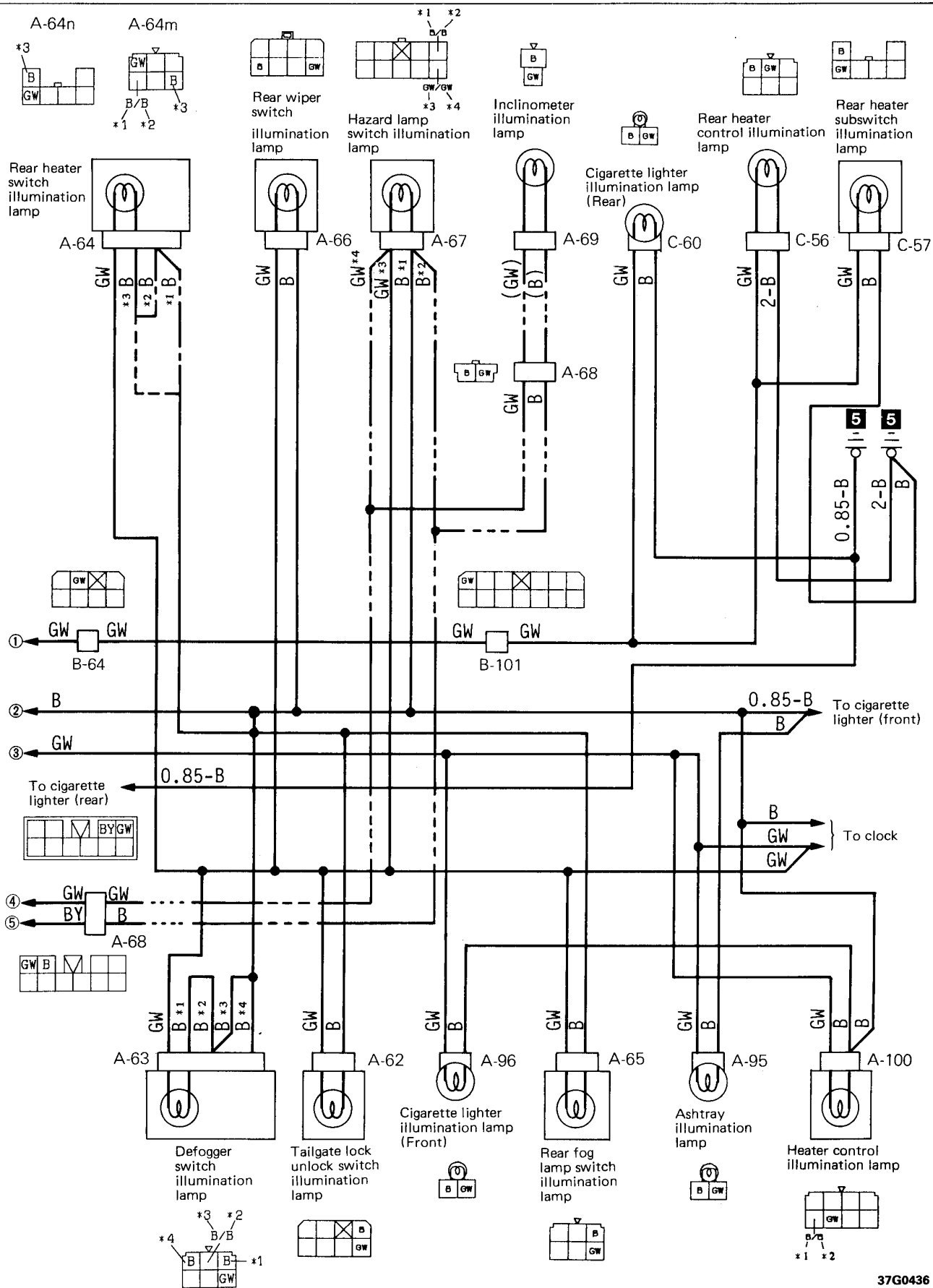

20 METER AND GAUGE CIRCUIT

20-1 Petrol-powered vehicles with carburetor

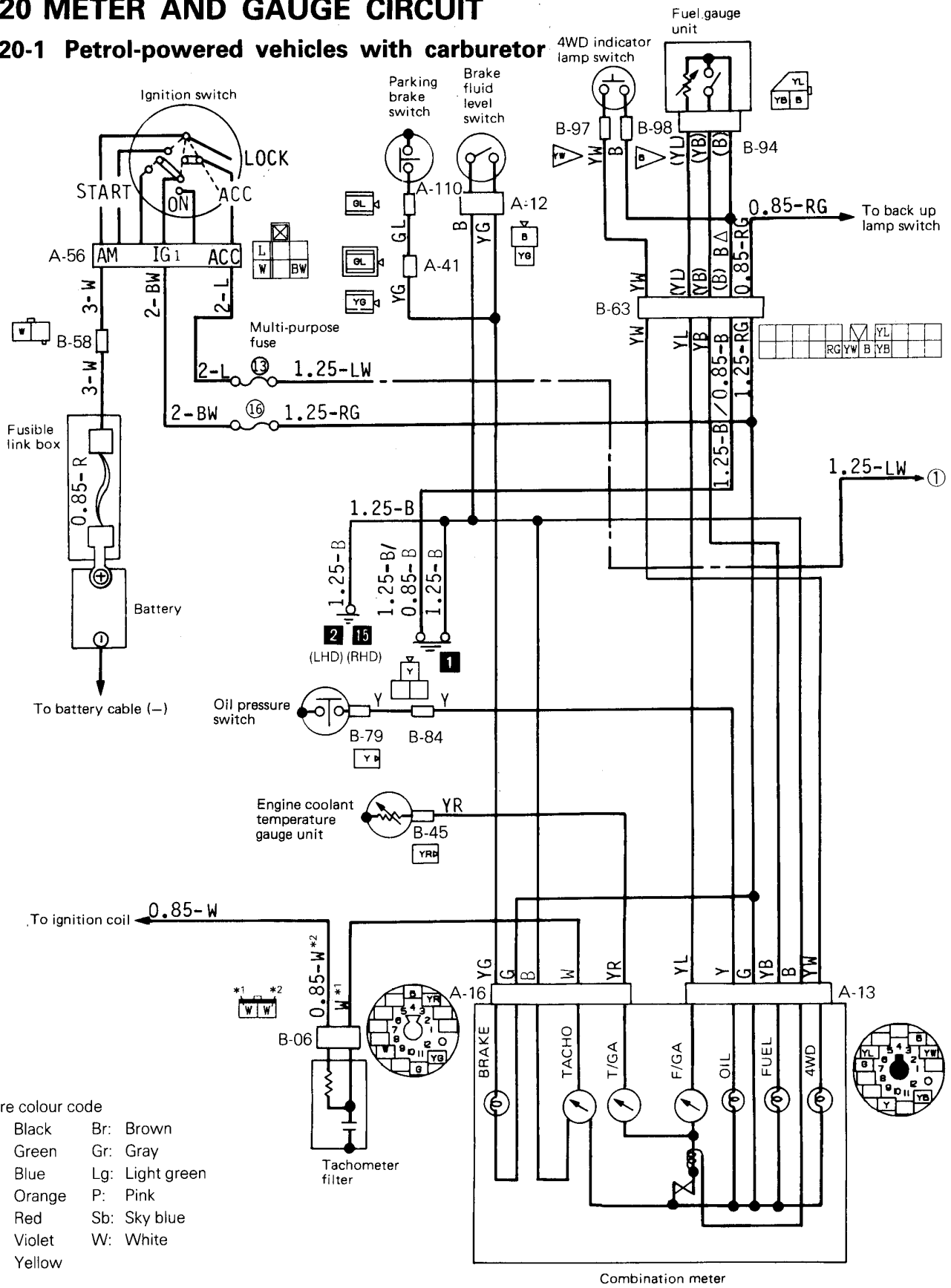

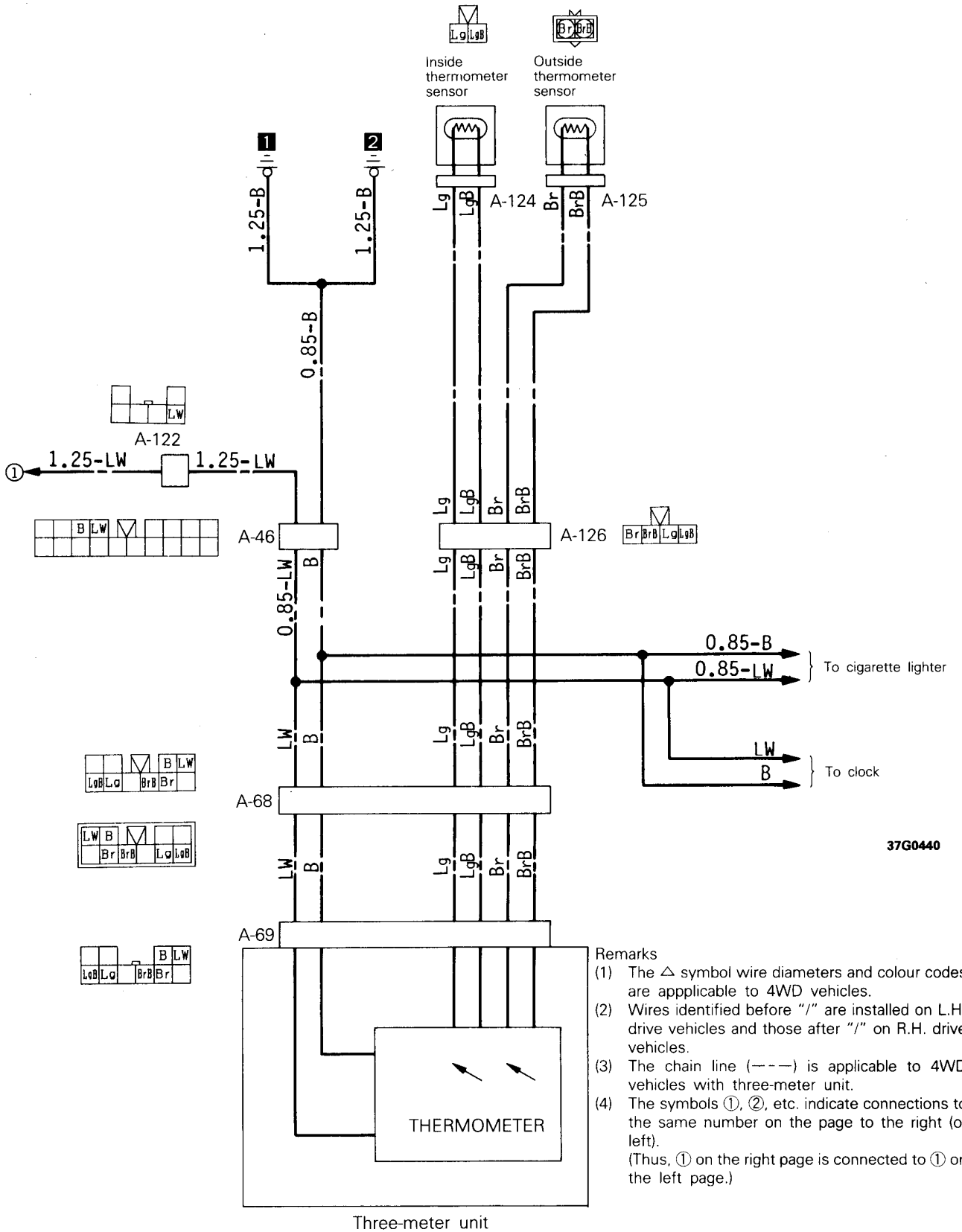

20-2 Petrol-powered vehicles with M P I

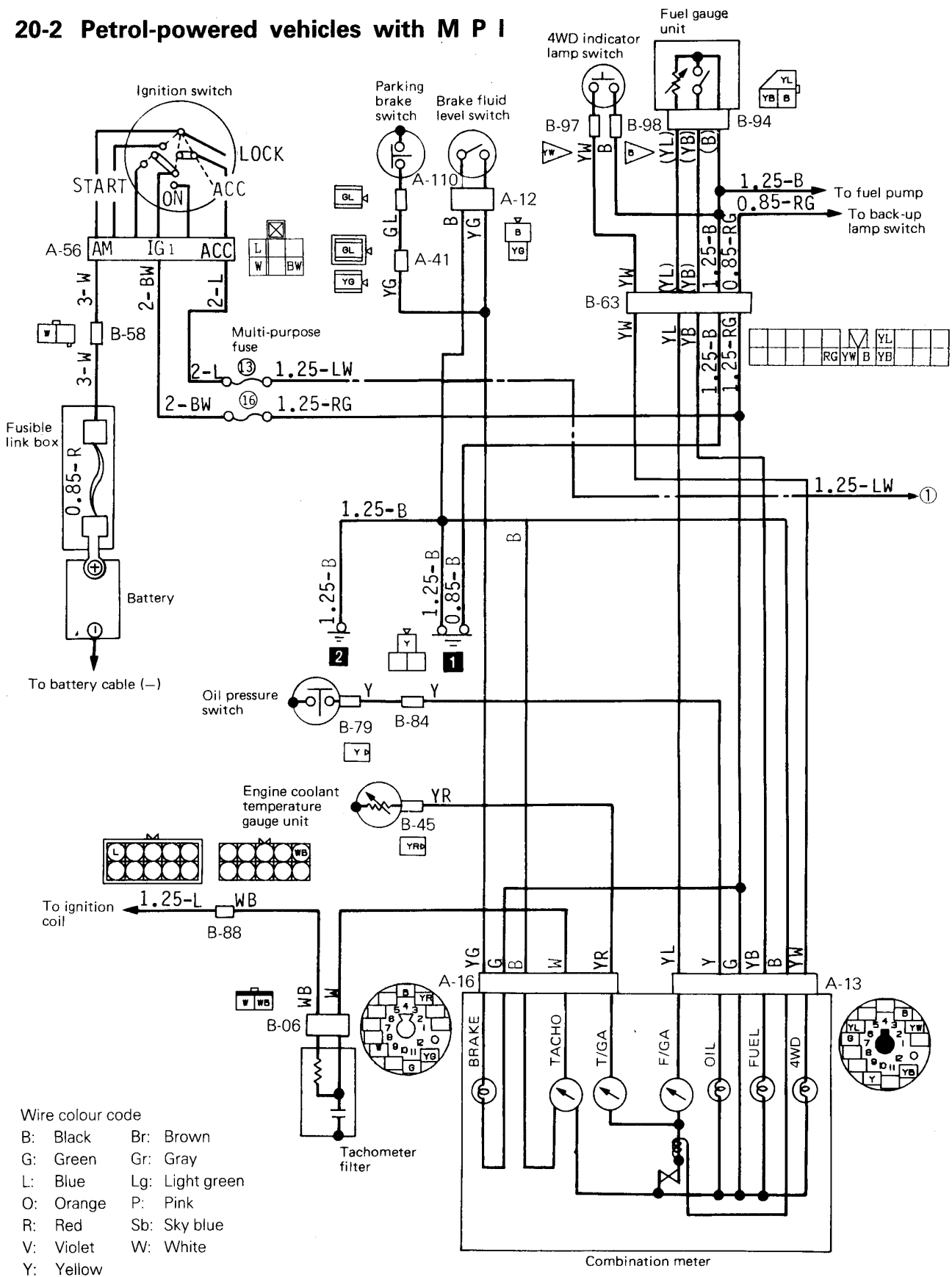

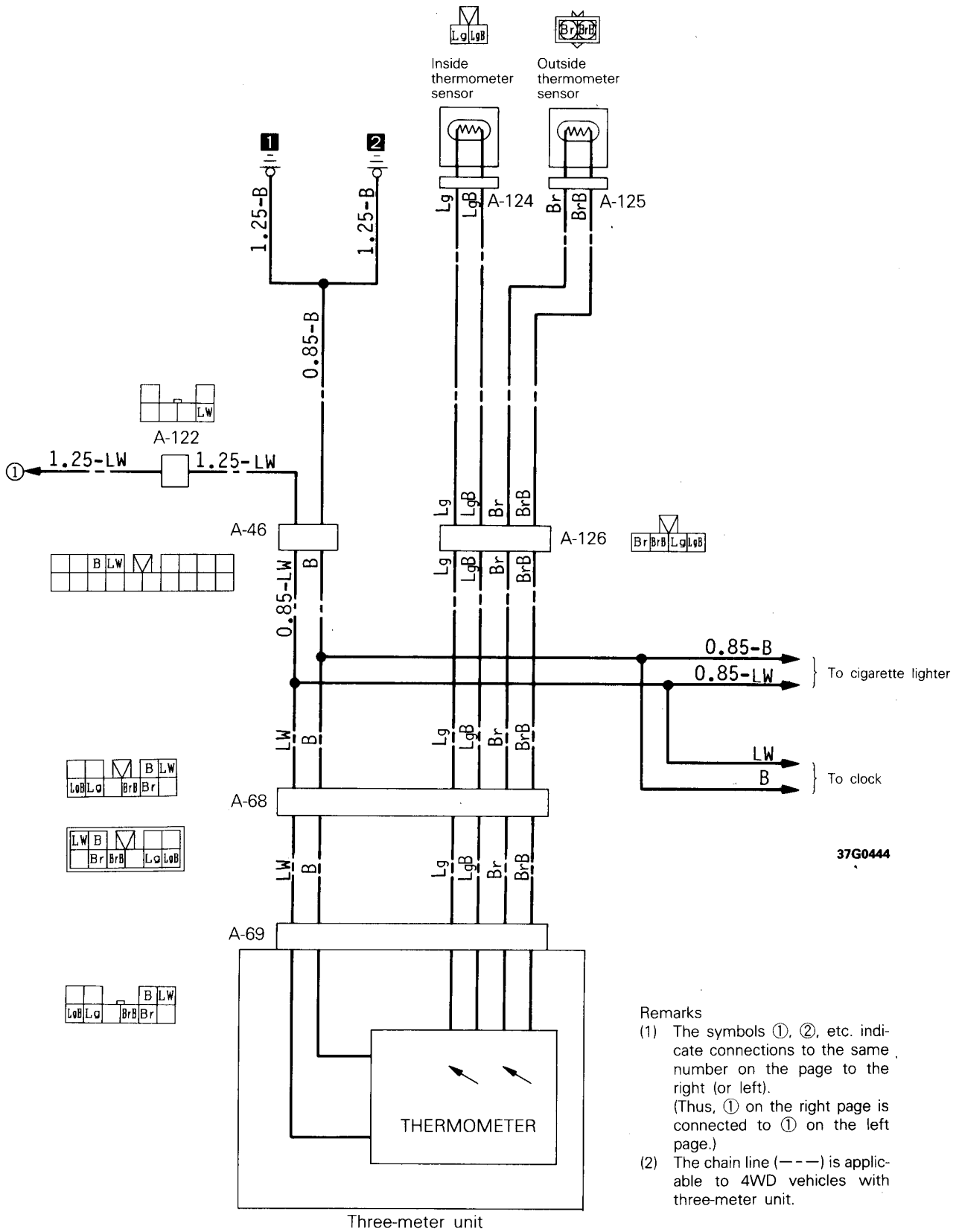

20-3 Diesel-powered vehicles

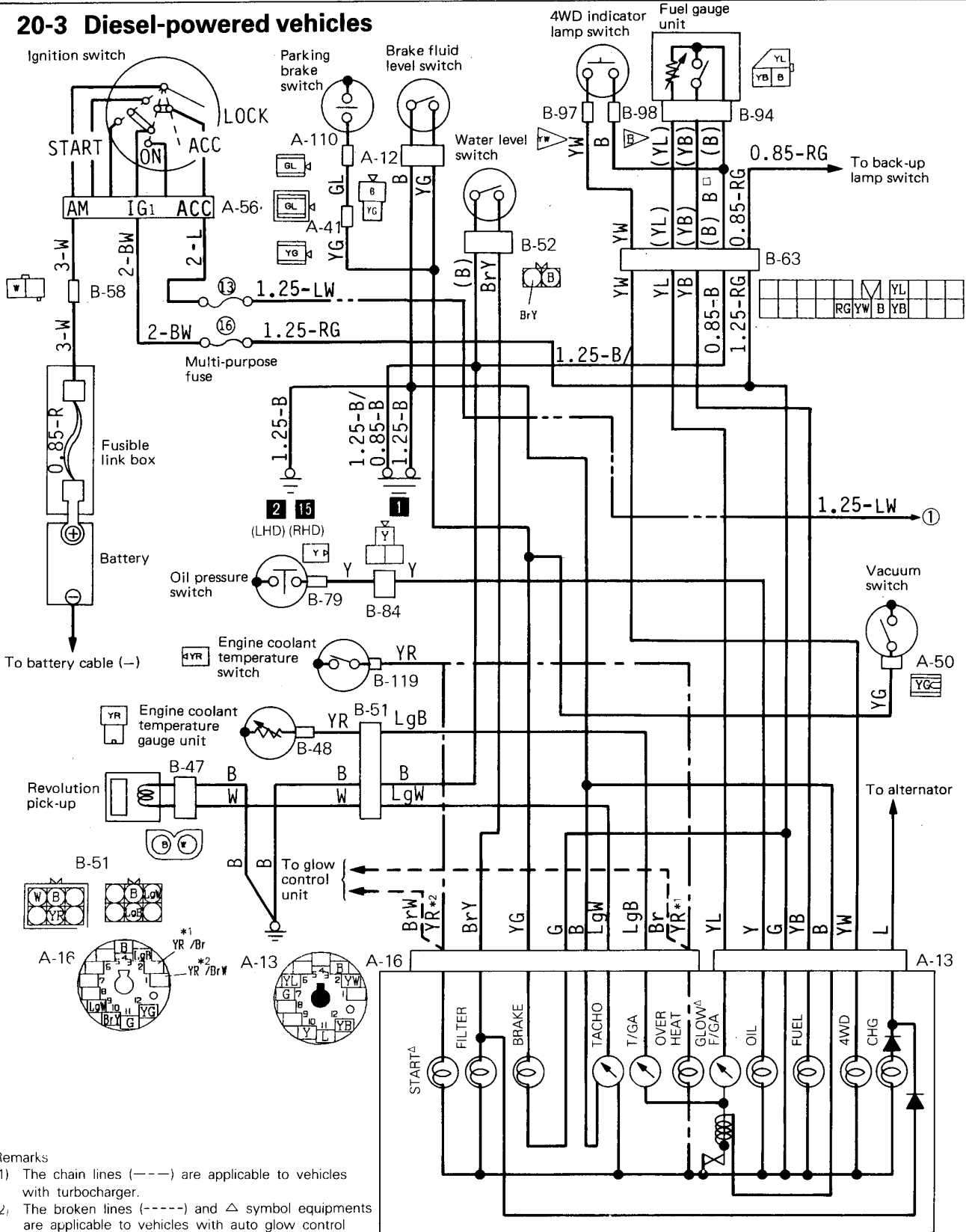

Remarks

- (1) The chain lines (---) are applicable to vehicles with turbocharger.
- (2) The broken lines (-----) and Δ symbol equipments are applicable to vehicles with auto glow control system.
- (3) The [] symbol wire diameters and colour codes are applicable to 4WD vehicles.
- (4) Wires identified before "/" are installed on L.H. drive vehicles and those after "/" on R.H. drive vehicles.
- (5) The symbols ①, ②, etc. indicate connections to the same number on the page to the right (or left).
(Thus, ① on the right page is connected to ① on the left page.)
- (6) The two-point chain line (-----) is applicable to 4WD vehicles with three-meter unit.

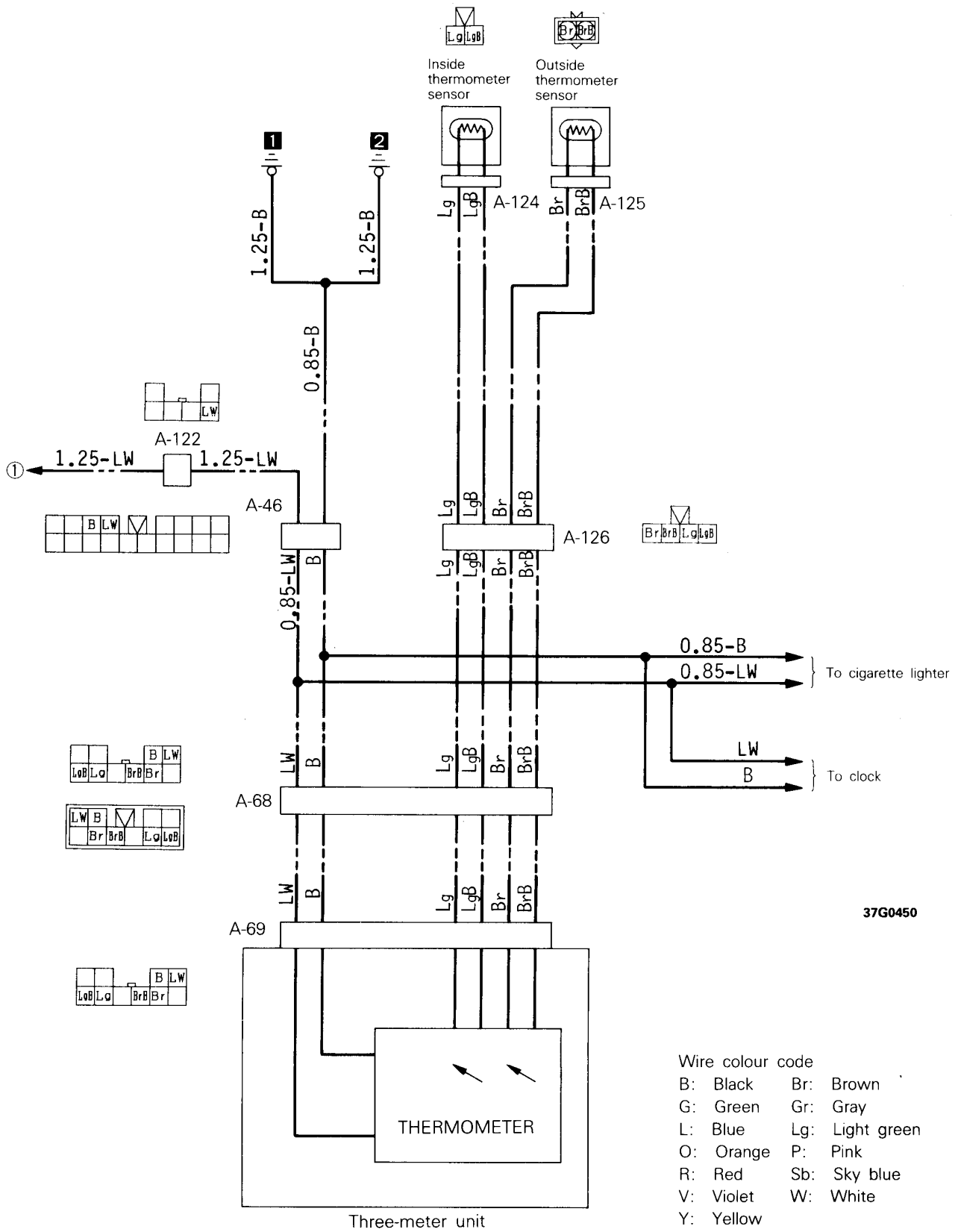

28 AUDIO CIRCUIT

28-1 5-door models

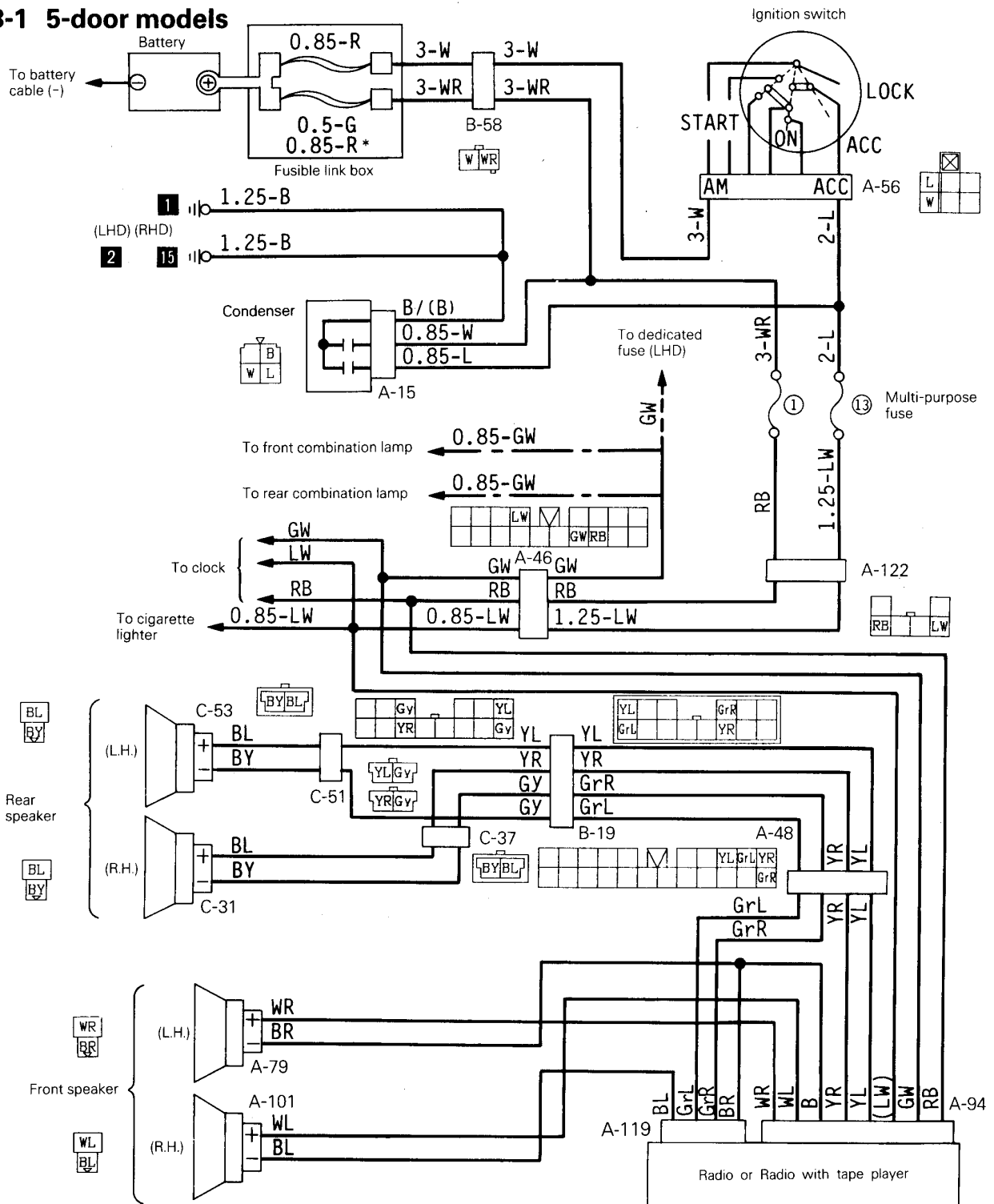

Remarks

- (1) The * symbol fusible link is applicable to vehicles with two bulb united type headlamp.
- (2) The broken line (----) is applicable to L.H. drive vehicles.
- (3) The chain lines (---) are applicable to R.H. drive vehicles.
- (4) Wires identified before "/" are installed on L.H. drive vehicles and those after "/" on R.H. drive vehicles.

Wire colour code

B:	Black	Br:	Brown	G:	Green	Gr:	Gray
L:	Blue	Lg:	Light green	O:	Orange	P:	Pink
R:	Red	Sb:	Sky blue	V:	Violet	W:	White
Y:	Yellow						

GrL	BR	WL	YR
GrR	BL	B	WR
		YL	RB
		LW	

37G0433

28-2 4-door models

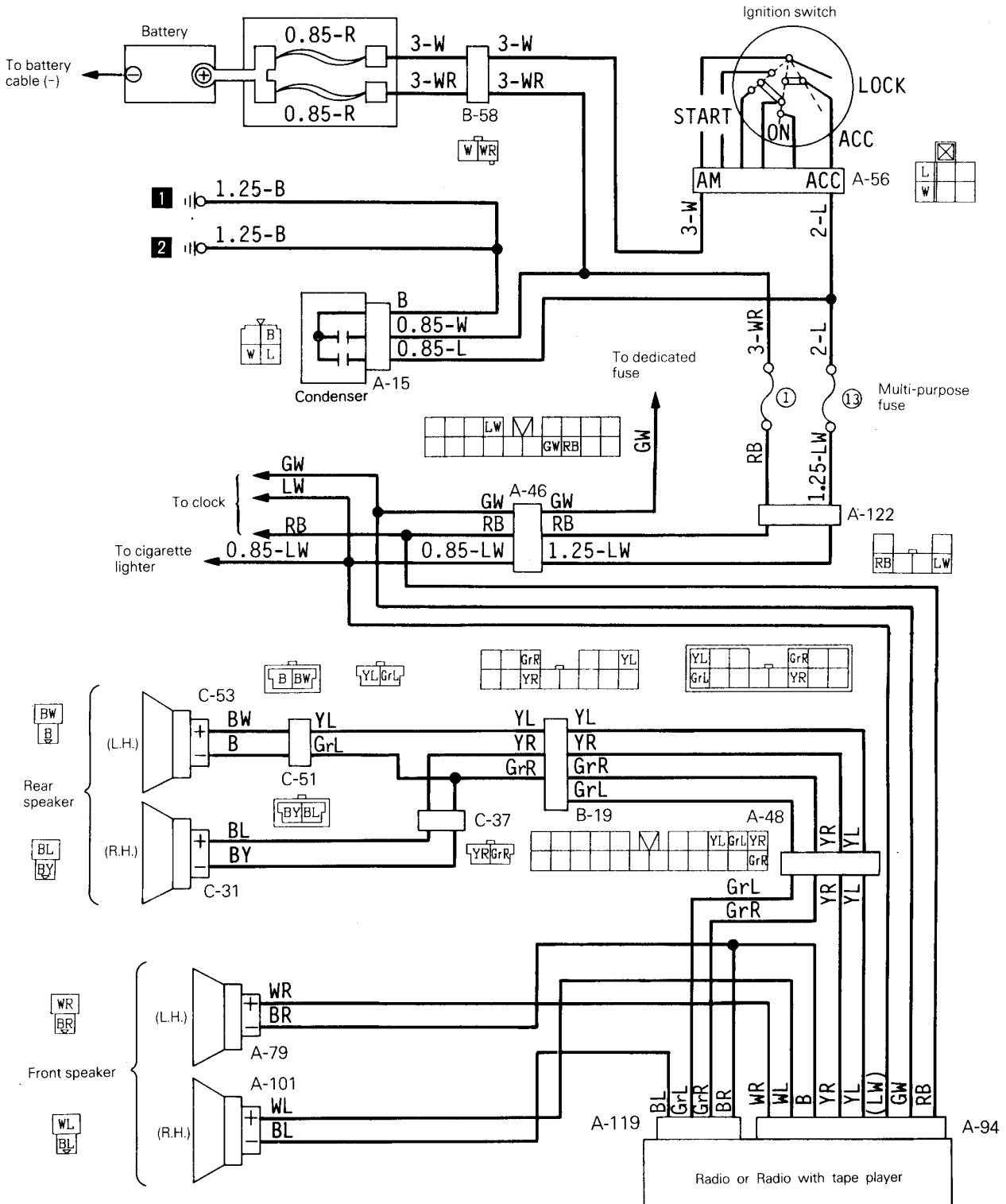

Wire colour code

- B: Black Br: Brown G: Green Gr: Gray
- L: Blue Lg: Light green O: Orange P: Pink
- R: Red Sb: Sky blue V: Violet W: White
- Y: Yellow



37G0434

35 CENTRALIZED JUNCTION**MULTI-PURPOSE FUSE**

Power supply circuit		Fuse No.	Rated capacity (A)	Load circuit
Battery		1	10	Clock, Room lamps, MPI control unit, Door lock control unit, Radio
Ignition switch	ACC	13	15	Radio, Tape player, Cigarette lighter, Three-meter unit
	IG1	16	15	Back-up lamp, FBC control unit, Alternator relay, Combination meter, Turn signal and hazard flasher unit, Buzzer assembly